

CPD APPROVED

GD26 ALUMINIUM FABRICATIONS: A GUIDE TO GOOD PRACTICE

1.0 INTRODUCTION

The Metal Cladding and Roofing Manufacturers Association (MCRMA) has produced guidance document GD26 *Aluminium fabrications: A guide to good practice* to accompany BS 5427:2016 + A1:2017 section 7.1. Both documents provide theoretical and practical guidance in the design and installation of aluminium fabrications, including fasteners and sealants.

At first consideration the design and installation of aluminium fabrications is a simple matter. However, experience has shown that in service, aluminium fabrications are a complicated interaction between multiple factors involving thermal expansion and contraction and the accommodation of associated stresses and movements by the fabrication, fasteners, seals and supporting structure.

The guidance in this document illustrates the issues and suggests solutions. These solutions are indicative; both BS 5427:2016 +A1:2017: section 7.1 and the design and installation advice of the manufacturers of the fabrications, fasteners and sealants used for a given project take precedence.

There are two principal approaches concerning fabrication fixing methods and, in some aspects, the widely used methods i.e. dead fix or floating fix offer contrasting approaches. However, there are a number of design considerations which are common to both dead fix and floating fix arrangements To explain; dead fix methodology is where each length of fabrication is attached to a robust structural sub-structure with every fixing being a fixed point, i.e. no oversize holes/slots, where each fixing resists and restrains against thermal expansion and movement.

In contrast, floating fix methodology is where each length of fabrication has a single dead fix (fixed point), usually at the centre of the fabrication, and all other fixings are floating i.e. through oversize holes/slots.

Like the dead fix methodology, the floating fix methodology relies on fastening into a robust structural substructure. The thermal expansion and movement are accommodated through these floating points (see sections 3.3.1 and 3.3.2).

The environmental conditions imposed on the fabrication and the physical properties associated with aluminium, as a product, determine the resultant expansion, contraction and forces within the section. These are common to both dead fix and floating fix design methodologies. However, the way in which they are accommodated and dealt with is quite different. The dead fix methodology requires specific and specialist project design advice from the fabrication manufacturers whereas the floating fix methodology may be dealt with using more general design guidance and understanding.

This guidance document expands on the information needed to assist designers and installer with the floating fix methodology and recognises areas of commonality.

Aluminium expands and contracts due to temperature change. Forces generated are large and can cause damage to the fabrication, structure and fasteners unless they are managed in a controlled manner. The forces and movement have to be accommodated by the fabrication, fasteners and sealants.

The design should consider the thermal movement for the particular circumstances of each project, using the principles in this document and BS 5427. This will include fabrication material, material colour, the length of fabrication, location of fixed point, temperature at installation, temperature range, insulation, method of sealing and a robust structural substrate. In conjunction with the fabrication manufacturer, the designer should consider whether dead fix or floating fix is appropriate for the project application.

The importance of the correct selection and application of fasteners and sealants is often underestimated by designers and left to the experience of the installer on site. This approach will in some cases lead to costly rectification if the design parameters are not fully assessed, quantified and accounted for at each stage of the development and for the life time of the building.

Project specific design could indicate lower movement than shown in this guidance document leading to more choice of suitable fasteners, washers and sealant materials. For all projects, the fastener and sealant manufacturers should be consulted and advised of all details and physical parameters to obtain the correct specifications for the given applications. With regard to the fasteners, details of the robust structural substructure will influence the final specification.

A fabrication may not be the primary weatherproof layer by design and can have an internal drained waterproof secondary flashing or membrane. In this respect, the aesthetic fabrication would act as a form of rainscreen and seals are still used but are not as critical.

Fabrications: For the purposes of this guide, aluminium fabrications are defined as sections with a material thickness of 1mm or more. These tend to be regarded as aesthetic; items such as bullnose and fascia etc. This guidance document is principally for fabrications, but some of the design principles can also be applied to flashings with appropriate consideration.

Flashings: For the purposes of this guide, flashings are defined as sections less than 1mm thick and generally less aesthetic and more functional in nature such as roof ridges and hips etc. Thin flashings of 0.9mm aluminium are generally used as flashings in conjunction with aluminium profiled sheeting or as part of an aluminium standing seam roof. The latter have bespoke detailing specific to the standing seam system with specific system supports for flashings. Flashings are specifically addressed in section 2.0

NOTE:

In all instances, it is essential that a specifier or project designer seeks and acts upon detailed advice from the system/fabrication supplier or manufacturer and involves the fastener and sealant manufacturers in the joint design and fastener specification

2.0 FLASHINGS

0.9mm aluminium flashings are relatively more flexible and tolerant than thicker fabrications. They are, however subject to the same environmental temperature variations resulting in expansion and contraction and undergo the same stresses and strains but mitigate some of the effect by flexing.

When fixing flashings, the following guidance applies:

- Follow the specific fixing regime stipulated by the roof/wall system manufacturer whichever is applicable.
- Fix ridge/hip flashings at typically 400mm centres maximum.
- Fix verges at typically 500mm centres maximum.
- Allow laps and butt strap joints to float.
- Follow the principles for fastener and sealant design in sections 4.0 and 5.0.

3.0 FABRICATION DESIGN

3.1 Material thickness

The minimum thickness recommended for aluminium fabrications is 1mm. Where appearance and structural integrity of prime importance, for example on fascias, due attention should be paid to consider and specify thicker aluminium and post-painting. Curved fascia fabrications may need to be up to 3mm in thickness, welded, surface dressed and factory post-painted. This tends to give a neater appearance than lock-formed thinner materials.

As a general guide, the unstiffened or unsupported widths and material gauges in Table 1 can be used. However, consideration should also be made regarding the strength and grade of aluminium being used for the application and the required finished quality. The thicker material option should be adopted where high aesthetic standards are required and the wider limit where appearance is not critical (behind parapets, for example). The mid-range should be suitable for most building purposes.

In all cases, a suitable lined and levelled support system is required. Aluminium fabrications should not be fixed to light gauge roof or wall sheets unless specifically designed for such a substrate.

Gauge mm	Unstiffened width mm
1.0	125-200
1.2	175-300
1.5	225-450
2.0	275-550
3.0	325-650

Table 1 Material gauges for unstiffened widths

Where there is a risk of bi-metallic corrosion, isolate aluminium fabrications from materials such as galvanised steel and timber containing copper preservatives using suitable self-adhesive PVC tape or other barriers. If in doubt, isolate.

Fasteners should also be chosen to avoid bi-metallic corrosion. This would usually be stainless steel or aluminium rather than carbon steel (refer to section 4.0)

3.2 Thermal movement

3.2.1 Temperature ranges

There are a number of sources of guidance for maximum and minimum temperatures that a building component will undergo. These are described below and the maximum and minimum values are shown in table 2.

3.2.1.1 BS EN (NA) 1991-1-5:2003: Eurocode 1: Actions on structures - Part 1-5: General actions - Thermal actions

The Standard deals primarily with structures and bridges but is also applicable to cladding [1.1(1)]. The National Annex to BS EN1991-1-5 includes two graphs giving minimum (T_{min}) and maximum (T_{max}) temperature isotherms for the UK [figs NA1 and NA2). These are then modified by a factor for orientation (i.e. south west facing: light colours, $T_4 = +30^{\circ}\text{C}$, and dark colours, $T_5 = +42^{\circ}\text{C}$).

Table 2 shows the worst-case values for the UK as a whole.

BS EN1991-1-5 does not differentiate between insulated and uninsulated assemblies.

BS EN1991-1-5 advises an initial (installation) temperature T_0 of 0°C for expansion and 20°C for contraction.

3.2.1.2 BS 5427:2016 + A1:2017 Code of practice for the use of profiled sheet for roof and wall cladding on buildings

BS 5427 gives a maximum temperature change over 24 hours, compared with maximum and minimum temperatures provided by other sources. BS 5427 table 7 gives a maximum 24-hour temperature change of 50°C for light colours and 70°C for dark colours.

3.2.1.3 Historic industry data

Historic industry data recorded maximum temperatures of various materials and colours through the extreme summer heat wave (drought year) of 1976. The spell of hot weather, from mid-June to the end of August included 15 consecutive days where a maximum temperature of 32°C or more was recorded somewhere in the UK. The measurements were taken on insulated assemblies and assemblies with a nominal 25mm air gap beneath. No minimum values are available.

3.2.1.4 University of Bath

In a 2014 research paper, *Factors Affecting the Accommodation of Thermal Movement in Halter Based Aluminium Standing Seam Systems* carried out by David Cottrell at the Department of Architecture and Civil Engineering of the University of Bath, temperatures and potential movement were analysed. While this is for aluminium roof systems with very long roof sheets, the principles and temperature values are relevant to fabrications. Data is provided for maximum and minimum temperatures for insulated aluminium systems only. Guidance is offered for installation temperatures.

The minimum surface temperature of -28°C is a minimum temperature of -20°C together with a -8°C allowance for drop in temperature due to night sky radiation. Initial (installation) temperature T_0 of -5°C for expansion and 25°C for contraction.

3.2.1.5 Oxford Brookes University

Thermal movement within aluminium fabrications formed part of a research project by Oxford Brookes University (OBU), sponsored by the MCRMA. OBU modelled fabrications using Finite Element Analysis (FEA), including insulated and uninsulated assemblies (nominal 25mm air gap) and various surface reflectivity/colours. The minimum surface temperatures include the night time clear sky radiation effects.

Summary

Source	Light colours		Dark colours		Insulated or air gap?
	Max °C (a)	Min °C	Max °C (a)	Min °C	
BSEN1991-1-5	65	-21	77	-21	?
BS 5427	50	n/a	70	n/a	?
Historic (steel)	61	n/a	71	n/a	Insulated
Historic (steel)	49	n/a	44	n/a	Nom 25mm air gap
Historic (mill AL)	67	n/a	n/a	n/a	Insulated
Historic (mill AL)	44	n/a	n/a	n/a	Nom 25mm air gap
Bath Uni	62	-28	78	-28	Insulated
OBU	68	-13.7	88	-14.3	Insulated
OBU	43	-8	65	-8.7	Nom 25mm air gap

Table 2 Summary of minimum and maximum temperatures

NOTE: Table 2, with a temperature at installation T_o of 0°C (BSEN1991-1-5) the maximum temperature equals the 24-hour temperature range.

The historic industry and OBU data indicate that uninsulated assemblies can have lower maximum temperatures with the figures above ranging from 20% to 38% lower; average 31% lower.

Maximum temperatures also vary around the country and an engineer should refer to BS EN(NA) 1991-1-5:2003 for temperatures specific to their project.

Selecting a maximum temperature for an application is not a precise science. Colour, orientation, location and cleanliness all have an effect. If in doubt, select data for dark colours.

For the examples in this guidance document, the following values in table 3 are used, based primarily upon BS EN(NA) 1991-1-5:2003. For illustration, maximum temperatures for uninsulated assemblies are shown 30% lower than the insulated values.

Surface colour	T _{max} °C (Insulated)	T _{max} °C (air gap)	T _{min} °C
Light coloured (Grey/white)	65	70% of 65 = 46	-21
Dark coloured (Slate grey/ mill finish aluminium)	77	70% of 77 = 54	-21

Table 3 Minimum and maximum temperatures used in the examples given in this document

Initial (installation) temperature To of 0°C for expansion and 20°C for contraction.

3.2.2 Expansion and contraction

The calculation of expansion and contraction per metre of section includes the coefficient of expansion, minimum or maximum temperatures and temperatures at installation.

$$\text{Movement} = \alpha \cdot \Delta T$$

α = the coefficient of expansion for aluminium = $23.3 \times 10^{-6} / ^\circ\text{C}$

ΔT = temperature change = $T_{\text{max}} - (-T_{\text{O}(\text{exp})})$ or $T_{\text{min}} - (-T_{\text{O}(\text{con})})$, °C

T_{max} = Max surface temperature, °C

T_{min} = Min surface temperature, °C

T_{O(exp)} = 0°C

T_{O(con)} = 20°C

Surface colour	Insulated or air gap	T _{max}	To _{exp}	Expansion	BS 5427 sect 7	T _{min}	To _{con}	Contraction	Suggested overall movement allowance
		°C	°C	mm/m	mm/m	°C	°C	mm/m	+/- mm/m
Light coloured (Grey/white)	Insulated	65	0	1.51	1.0	-28	20	-0.96	1.51
Dark coloured (Slate grey/ mill finish AL)	Insulated	77	0	1.79	1.3 or 1.5	-28	20	-0.96	1.79
Light coloured (Grey/white)	Air gap	46	0	1.07	1.0	-28	20	-0.96	1.07
Dark coloured (Slate grey/ mill finish AL)	Air gap	54	0	1.26	1.3 or 1.5	-28	20	-0.96	1.26

Table 4 Theoretical summary of expansion and contraction

Table 4 provides theoretical figures for expansion and contraction for a range of conditions. However, from practical experience the expansion and contraction of aluminium fabrications is generally considered to be in the order of +/- 1mm/m and this level of allowance should form the basis for a practical solution in the majority of situations.

For situations which are outside of the norm then specific design calculation should be conducted and the advice of the manufacturer or fabricator should be considered within the application.

Fasteners installed at floating fix positions on the fabrication must be placed centrally to an oversize hole or slot (using a self-centring tool if possible). The BS 5427 movement is from section 7.1.2.1, table 7 and section 7.1.2.6 of the Standard.

3.2.3 Forces

The example below is for dark coloured uninsulated aluminium fabrications (i.e. with an air gap beneath the fabrication).

The restrained stress exerted by thermal effects is related to the cross-sectional area and temperature change. Stress = $\alpha.E.\Delta T$; force = $\alpha.E.\Delta T.A$

α = the coefficient of expansion for aluminium = $23.3 \times 10^{-6} / ^\circ\text{C}$

E = Young's modulus = 70000N/mm^2

ΔT = temperature change = $54 - (-0) = 54^\circ\text{C}$ (Dark colour, uninsulated)

A = cross-sectional area of a section or fabrication = girth x thickness, mm^2

$\alpha.E.\Delta T = 88.07\text{N/mm}^2$

If a section is 2mm thick and 1000mm girth, the force generated is: -

$\alpha.E.\Delta T.A = 88.07 \times 2 \times 1000 = 176150\text{N} = 176.1\text{kN} = 17956\text{kg} = 17.96 \text{ tonnes!!}$ That is, the forces are massive and have to be allowed for in design.

The expansion and contraction calculated in section 3.2.2 and shown in Table 4 and the forces calculated in section 3.2.3 for the particular design parameters will be distributed within the fabrication and induced into the support structure and should be recognised and accommodated in designs based on either dead fix or floating fix arrangements.

Designers and installers must take this movement and force into account in order to avoid unwanted flexing, buckling and even tearing of the material. Unless managed, the stresses will load the fasteners and supporting structure to a point where fixing failures will occur or the fabrication tear.

Daily expansion and contraction of an assembly can 'work' some fasteners resulting in a slow but steady un-winding of the threads and fabrications/flashings becoming loose or detaching from the sub structure or adjoining materials and resulting in a potentially dangerous situation.

3.3 Fixing methods

The designer has a choice about how to attach fabrications to the robust substructure. As described earlier there are two approaches – dead fix or floating fix and these are described in more detail below.

3.3.1 Dead fix

Dead fix methods involve direct fixing a fabrication to a robust structure without the inclusion of oversize holes/slots and restraining forces and any potential movement. This involves specialist design including Finite Element Analysis (FEA) of the application for each location. The advice of the fabrication manufacturer and specialist should be sought and followed in terms of assessing expansion and induced forces within the fabrication and the local influence on fasteners, sub-structure and sealing. This method of attachment and restraint requires specialist design analysis and a user should consult the fabrication manufacturer for specific project design advice.

3.3.2 Floating fix

Floating fix methods involve a fabrication allowing movement at fastener locations and at junctions between fabrications. A fabrication has one dead/fixed point fastener location and floating fasteners for the remaining fastener locations.

3.3.3 Fastener position: fixed point / floating fix method

For most applications the fixed point / floating fix method of fastening aluminium components will accommodate movement provided that care is taken to detail and install correctly.

3.3.3.1 Fixed point

Typically, the fixed point will be consistently at one end or at the mid-point position of each section. The fasteners can be conventional self-drilling fasteners with washers or suitably specified rivets.

The installer should install one 'fixed point' or a single point 'dead fix' within the length of each section of the fabrication.

Preferably, this should be at the centre rather than at one end; this could be a single fastener or a set of fasteners grouped together, applied into the supporting robust sub-structure.

The fixing will be solid with no movement capability. Where the fixed point comprises more than a single fastener, care must be taken to set them across the girth at right angles to the length of the section.

NOTE: For this arrangement there can only be a single fixed point for each metal section.

3.3.3.2 Floating fix

Subsequent fixings will allow the fabrication to 'float' using, for example, an oversized or slotted hole, or sliding clip to allow the aluminium to slide across the fixing. In this way all thermal movement will happen along each metal section from the fixed point towards and past the floating fixing(s) - see Figure 1. Ideally, if a slot is adopted, it should be factory punched and have smooth sides. If site cut, the slot sides must be smooth.

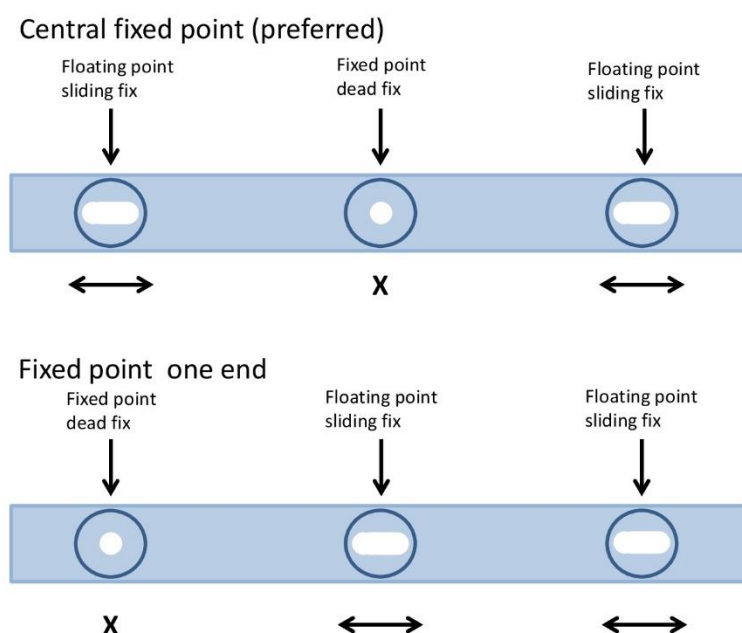

Figure 1: Examples of fixed point and floating point

Clearly, adequate arrangements must be made to manage the expansion and contraction at the end of each section as well as 'slippage' or movement at the floating fastener positions.

Design	Fabrication Colour	Insulated or uninsulated (air gap)	Fabrication length	Max distance from fixed point	Fastener dia	Movement	Hole size (slot or oversized hole)	Min expansion gap
			m	m	mm	+/- mm/m	mm	mm
Fixed point at one end	Dark	Air gap	3	3	5.5	1.26	13.1	3.8
Fixed point at one end	Light	Air gap	3	3	5.5	1.07	11.9	3.2
Fixed point at the mid-point:	Dark	Air gap	3	1.5	5.5	1.26	9.3	3.8
Fixed point at the mid-point:	Light	Air gap	3	1.5	5.5	1.07	8.7	3.2

Table 5 Theoretical fastener hole sizes and expansion gaps

Table 5 shows the potential movement hole size for 5.5mm dia fasteners, for fabrications with either an end fixed point or centre fixed point and for fabrications with an air gap. Table 5 illustrates that mid length fixed positions in each 3m section results in a lot less movement at each floating fastener position and therefore expansion and contraction can be more easily accommodated with a smaller slot or oversize hole.

This calculation assumes that adjacent fabrications follow a consistent LHS or RHS rule for the fixed point position. From this it is obvious that mid-point fixed positions in each 3m section would be a preferred option.

In all cases, fasteners should be located at the centre of the expansion slot. See figure 2 for examples of fabrication junctions

Note that fasteners nearer the fixed point location undergo a smaller movement (table 6 shows dark colour, mid-fabrication fixed point).

Distance from fixed point	Screw dia	Movement	Hole size
mm	mm	+/- mm/m	mm
0 (i.e. fixed point location)	5.5	0	5.5
500	5.5	0.63	6.8
1000	5.5	1.26	8.0
1500	5.5	1.89	9.3

Table 6 Theoretical movement vs distance from fixed point

NOTE: The hole sizes shown in tables 5 and 6 above are the theoretical sizes depending on the distance from the fixed point. For practical reasons, it may be preferable to make all hole sizes for floating positions a single and convenient size based on that for the maximum distance from the fixed point.

A 3m dark coloured uninsulated aluminium fabrication will expand and contract by max +/- 1.89mm at each end if it has a fixed point at its mid-point.

If the junction between the fabrications has a common fastener, for example with a butt strap welded or bonded one side and fixed the other, or with a straight forward lapped junction, the movement at that fixing would be max $(1.89+1.89) + 5.5 + (1.89+1.89) = 13.1\text{mm}$ (rounded up). The welded or bonded butt strap means that movement is transferred to the fastener, increasing the movement allowance required.

Note also that 5.5mm has been used in the examples for the fastener diameter. Other diameters are available including 4.8mm, 6.3mm and 8mm. The movement allowance should be calculated using the fastener diameter chosen for the application.

The washer diameter should be selected to ensure a full circumference seal by contact with the flashing/fabrication where there is a requirement for the connection to be sealed. The fastener manufacturer or supplier should be consulted for guidance about appropriate options for washer diameter.

Thermal movement occurs in every direction from a fixed point, i.e. the girth (width) will also expand and contract. For a narrow fabrication of, for example, 300mm girth this should not cause problems. On the other hand, for a very large bullnose of 1m or greater girth, the fastener slotted holes across the width must take into account the possibility of expansion/contraction across the girth, in addition to movement along the length.

The temperature at installation also has an effect. In midwinter, when the aluminium is cold it will be at its shortest and warm weather expansion has to be allowed for. In midsummer, on a hot day the metal will be at its longest and cold weather contraction must be allowed for instead. If in doubt, and to avoid site errors, then design for the maximum extent and place fasteners centrally within a slot. If oversize circular holes are used, a centring tool should be used to ensure the fastener is at the centre or bulls eye position.

3.4 Secondary weatherproofing

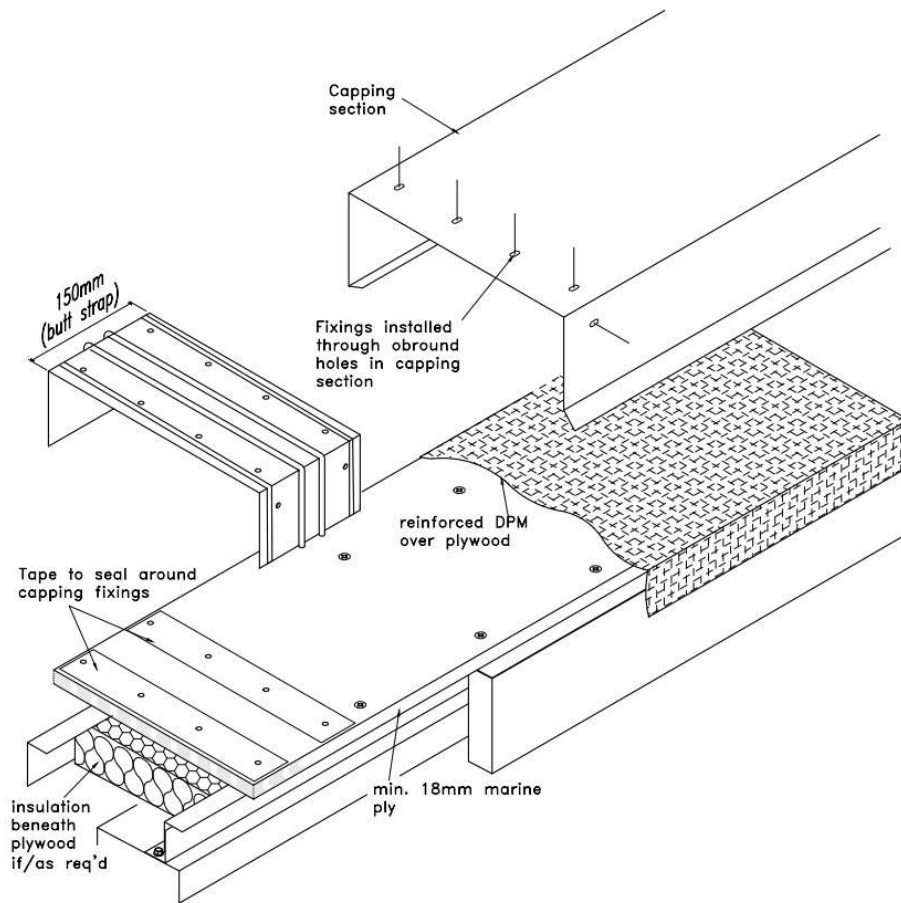

Figure 2: Typical aluminium capping systems with secondary weathering membrane supported by marine ply board

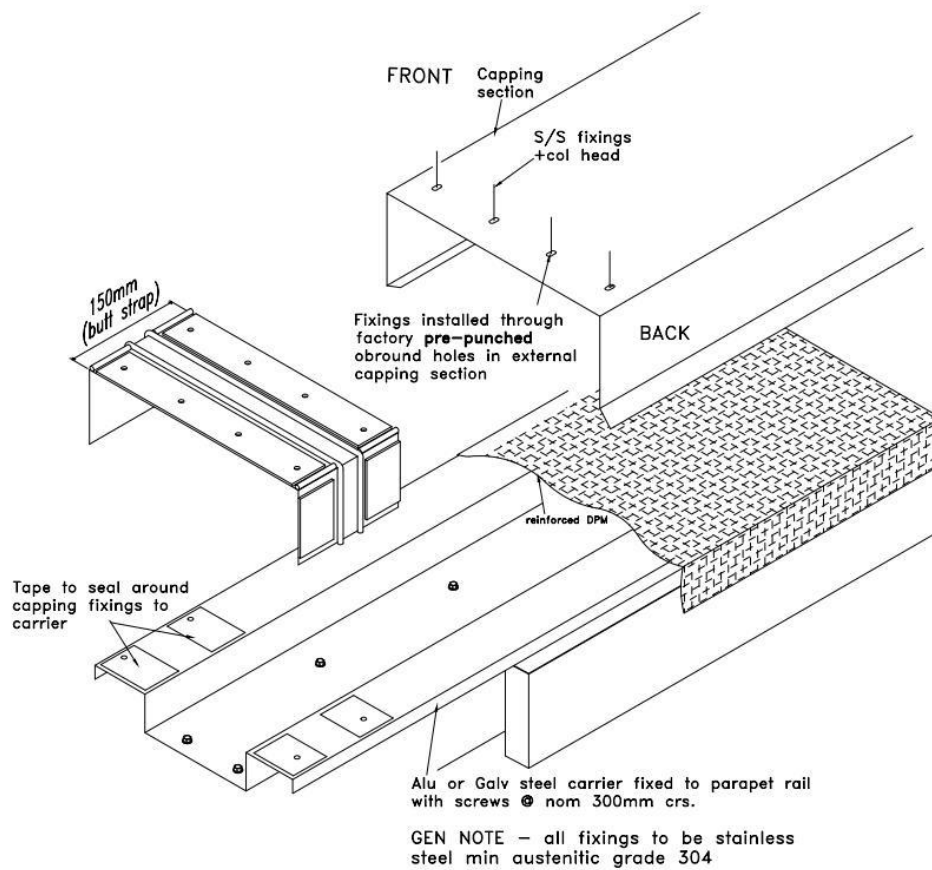

Figure 3: Typical aluminium capping systems with secondary weathering membrane supported on aluminium or galvanised steel carrier

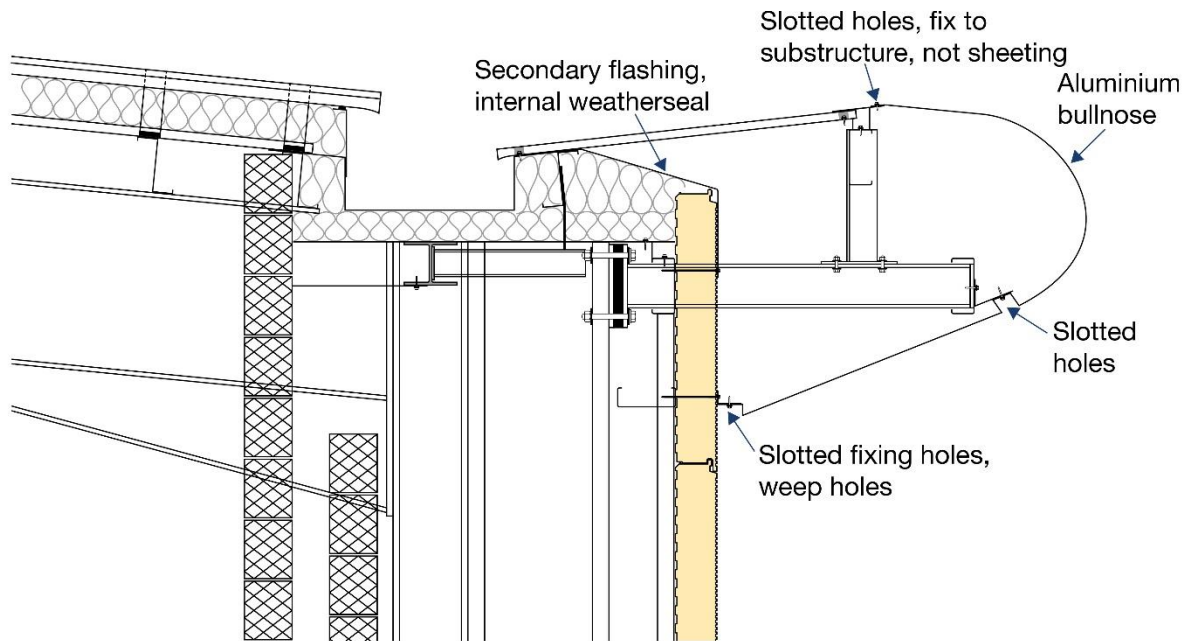

Figure 4: Bullnose showing connection to the structure

Experience has shown that the performance required of sealants in confined joint sizes in aluminium fabrications is very demanding and that the use of a secondary weatherproofing layer on the underside of the fabrication is prudent. This primarily concerns aesthetic fabrications thicker than 1mm (bullnose/fascia/verge)

Junctions and connections should be properly sealed as described in this guidance document, but with the installation of a secondary weathering layer within the detail so that, should the junction wear and age, there is a second barrier to prevent the ingress of water.

This can take the form of a secondary metal flashing or supported membrane. This layer should drain externally via weep holes suitably positioned in the outer aesthetic fabrication.

3.5 Fabrication joints

Fabrications of material greater than 0.9mm thick should always involve butt straps, preferably factory bonded to one side. Typical joint details are shown in Figures 4, 5, and 6.

All junctions between adjacent lengths of fabrications involving simple overlaps or butt strap should include an allowance for accommodating movement, fixings and seals. The junctions should also include spacers to ensure the seals are not over compressed. Specific advice and guidance should be obtained from the supplier.

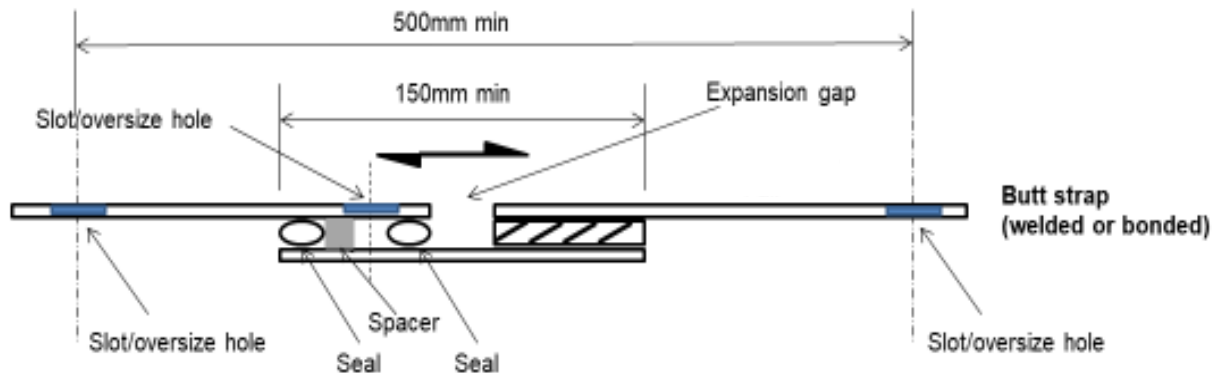

Figure 5: Floating fix and welded or bonded arrangement across butt strap

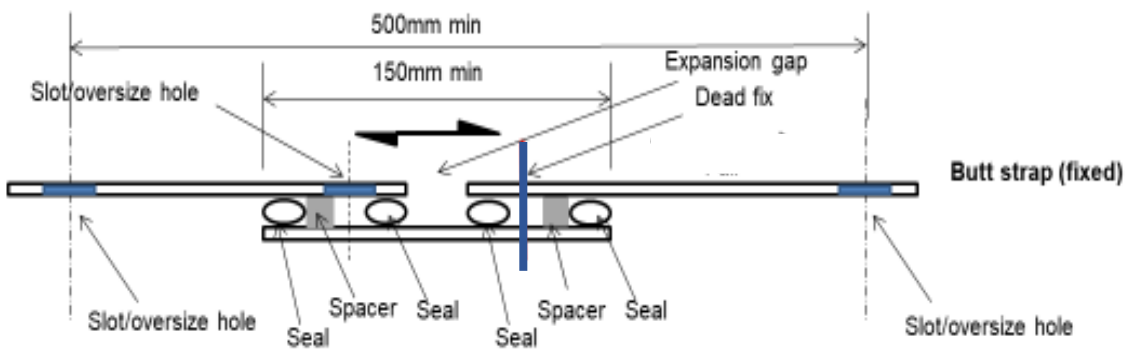

Figure 6: Floating fix and dead fix arrangement across butt strap

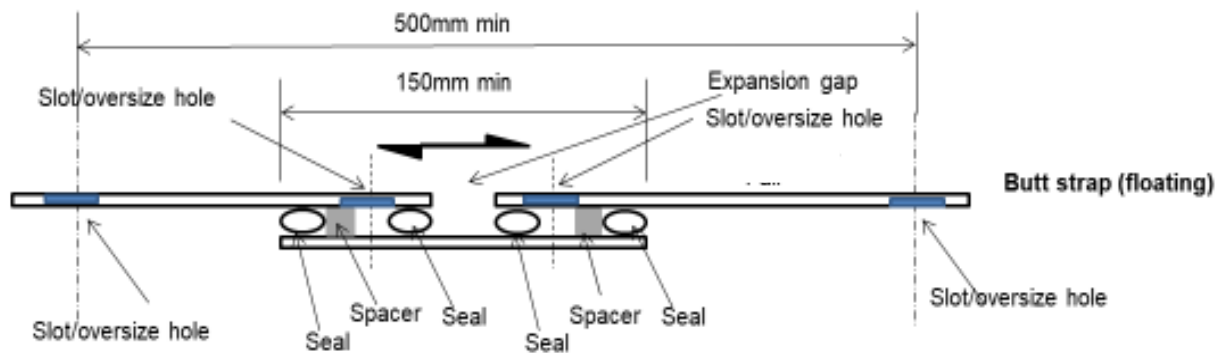

Figure 7: Floating fix arrangement on both sides of butt strap

4.0 FASTENERS

The fastener manufacturer should be consulted to obtain the correct fastener specification for the application. For detailed guidance refer to the MCRMA guidance document GD33 *Fasteners for metal roof and wall cladding: design, detailing and installation guide*.

Fasteners joining fabrications together must be purpose-designed for the application. These are generally either self-drilling stainless steel fasteners or alternatively aluminium or stainless steel rivets. Fasteners should have integral colour heads and bonded sealing washers. Separate push-on colour caps do not have long-term durability.

Fasteners for fabrications should be applied into a robust sub structure designed to withstand forces applied by the fabrication (self weight, wind loads, thermal effects). A galvanised steel sub structure should typically be 1.5mm or thicker.

NOTE: Where there is a risk of bi-metallic corrosion, isolate aluminium fabrications from materials such as galvanised steel and timber containing copper preservatives using suitable self-adhesive PVC tape or other barriers. If in doubt, isolate.

Stainless steel self-drillers, must be selected to drill the precise thickness of the substructure and, where applicable, the fabrication (i.e. on both dead fix and floating fix points) as recommended by the self-driller supplier. For stainless steel or aluminium rivets, the pilot hole sizes in the substructure must be as recommended by the rivet supplier and consideration made to their shear and tensile performance.

Fasteners across a lap or butt joint need to clamp and hold the two surfaces together and also firmly compress, but not squeeze out the sealant. This requires them to be installed at 75-100mm centres to avoid opening up under the load. Fabrications must be well secured to the structure or sheeting and maximum centres of 500mm are recommended, designed to suit the fabrication profile shape.

All screw fasteners that are used for fixing aluminium should be made from austenitic stainless steel (A2 or A4 grade). Carbon steel fasteners must not be used due to its high bimetallic corrosion risk when in contact with aluminium fabrications and flashings.

4.1 Examples of incorrectly specified fasteners



Figure 8: Consequence of no movement allowance at fastener location: fastener backing out of a capping

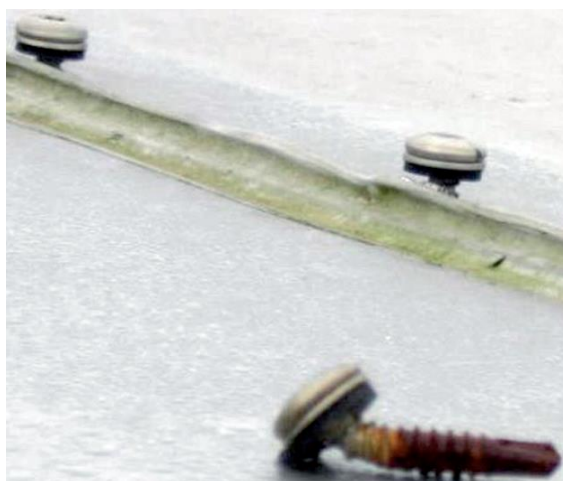

Figure 9: Consequence of no movement allowance: fastener shape demonstrates the high thermal movement loads developed. Carbon steel fasteners and those with carbon steel drill points are unsuitable for the application

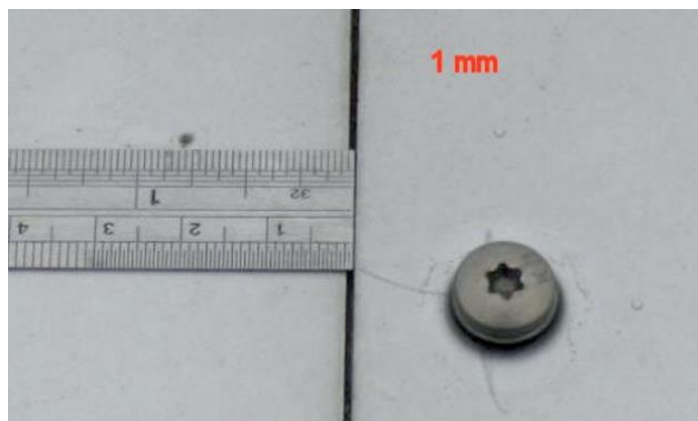

Figure 10: Insufficient expansion gap at fabrication junction

A correctly set fastener, with the sealing washer element deployed as the designer intended, will be less at risk of backing out than a heavily over-tightened fastener. Over-driving must be avoided. A correctly set tool will resolve many of the fixing problems experienced and it is recommended that all aluminium fabrications are secured using low torque or slow speed screw guns, preferably battery powered. See MCRMA Guidance Document GD32 *Self drilling fastener installation tools*



Figure 11: Fastener backing out of a capping: deformed washer indicates over-driven fastener

To fix aluminium fabrications to 'thin' steel or aluminium use all stainless steel rivets or screw fasteners specifically recommended by the manufacturer. Fasteners should incorporate suitable washers for applications with oversize holes or slots, giving cover to the potential movement. Only the outer section of fabrications should incorporate oversize holes or slots. Do not use oversize holes or slots in the inner section of the fabrication or the sub structure; the correct pilot hole size is important when rivets are used. A slot must be smooth sided to avoid snagging and should preferably be factory punched.

5.0 SEALANTS

The selection and specification of a sealant and spacer strip for a project requires specialist knowledge and is outside the scope of this document. Selection should be carried out with the input from the sealant manufacturer to ensure that the sealant materials chosen and joint dimensions are suitable for the application and anticipated movement.

Note that sealant manufacturers refer to the dimension between metal surfaces as the width (W) and the dimension across the lap as the depth (D) (see figure 9).

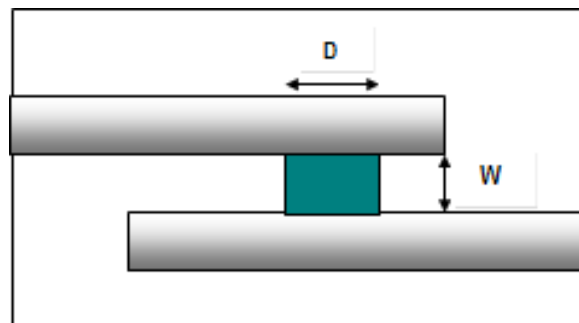

W = Width of sealant (often referred to as the thickness)

D = Depth of sealant

Figure 12: Sealant dimensions

Designing correctly and then constructing the sealant joint to the design is a key factor in obtaining a reliable and durable weather seal.

Simply laying a line of wet sealant onto the two metal surfaces and then fixing everything together as tightly as possible will result in the bulk of the sealant being squeezed out of the joint leaving only a thin film behind. When movement occurs, sealant failure and leakage can ensue.

To prevent wet sealant from squeezing out of the joint during assembly, incorporate a medium density compressed foam tape or shimmed preformed butyl strip sealant bonded to one face of the joint, alongside the sealant bead.

This acts as a spacer, preventing over-compression of the sealant and subsequent reduction in the bead thickness as the adjoining fasteners are tightened (see Figure 11).

The sealant manufacturer should always be consulted for compatible and appropriate sealants.

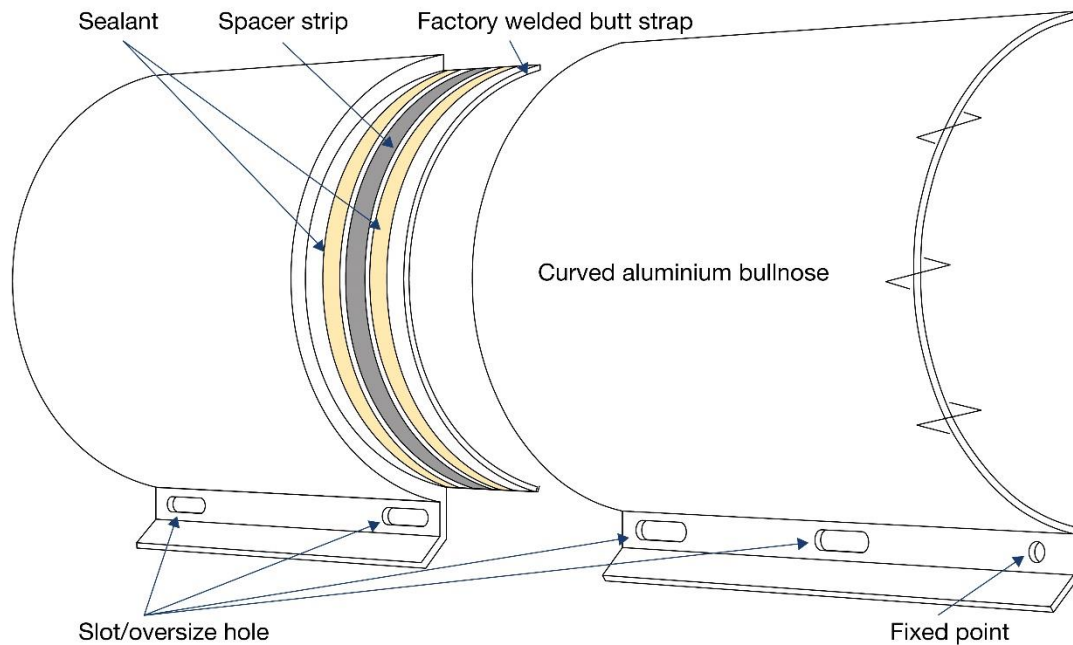

Figure 13: Welded butt strap on aluminium bullnose

NOTE: Slot/oversize holes and fasteners are not shown around the butt joint of the bullnose for clarity

6.0 SUMMARY

- Aluminium fabrications consist of an assembly of the aluminium sections, sealants and fasteners.
- An aluminium fabrication (bullnose, fascia) can be designed as a 'rainscreen' with a secondary weatherproof internal flashing/membrane.
- Aluminium fabrications and flashings will undergo thermal expansion and contraction.
- For dead fix designs using FEA design:
 - Consult the fabrication manufacturer for project specific fixing and sealant guidance

- For floating fix designs:
 - Fabrications should be no longer than 3m in length and mid-section fixed points are required to minimise the effects of expansion and contraction.
 - Fasteners, other than those used to create a dead/fixed point, must accommodate movement in the form of an oversize hole or slot in the outer section.
- Sealants must accommodate movement.
- Involve both the fastener manufacturer and sealant manufacturer in the design and materials specification for joints.
- Show the fixed points, fasteners and sealants in the installation drawings (materials, dimensions, locations, spacings etc).

Adoption by industry of the guidelines outlined in this document will lead to better and more consistent standards of metal roofing and cladding construction.

MCRMA member companies can advise on the suitability and performance of materials, systems and assemblies to ensure that aluminium fabrications are calculated properly and specified accordingly. In addition, design information can be obtained from any of the independent roofing and cladding inspectors featured on the MCRMA web site at www.mcrma.co.uk



MCRMA ONLINE CPD PROGRAMME

This guidance document is available as an online CPD and is accredited by the CPD Certification Service. The MCRMA online CPD programme is open to anyone seeking to develop their knowledge and skills within the metal building envelope sector. Each module also offers members of professional institutions an opportunity to earn credit toward their annual CPD requirement.

MCRMA provides informative self-study training, delivering good learning value with an online assessment to check knowledge. The course material is an informative self-study with an online evaluation to test knowledge. It is a training with learning and CPD value accredited by the CPD Certification Service. This module has an anticipated CPD value of 120 minutes or equivalent.

You can take the module at <https://mcrma.co.uk/online-cpds>

REFERENCES

BS 6213:2000+A1:2010 *Guide to selection of constructional sealants*

BS 5427:2016+A1:2017. *Code of practice for the use of profiled sheet for roof and wall cladding on buildings.*

BS EN(NA) 1991-1-5:2003: *Eurocode 1: Actions on structures - Part 1-5: General actions - Thermal actions*

BS EN ISO 11600:2003+A1:2011 *Building construction -- Jointing products -- Classification and requirements for sealants*

Cottrell David *Factors Affecting the Accommodation of Thermal Movement in Halter Based Aluminium Standing Seam Systems* (www.cibse.org)

ISO 11600:2001 *Building construction -- Jointing products -- Classification and requirements for sealants*

MCRMA publications

GD32 *Self drilling fastener installation tools*

GD33 *Fasteners for metal roof and wall cladding: design, detailing and installation guide*

DISCLAIMER

Whilst the information contained in this publication is believed to be correct at the time of publication, the Metal Cladding and Roofing Manufacturers Association Limited and its member companies cannot be held responsible for any errors or inaccuracies and, in particular, the specification for any application must be checked with the individual manufacturer concerned for a given installation. System manufacturer guidance takes precedence for their specific systems.

Information provided by the MCRMA or contained within publications and articles which are made available in any form (mechanical, electronic, photocopying or otherwise) cannot be used or cited as a means of ensuring that a material, product, system or assembly is compliant with Building Regulations.

All rights reserved. The material may not be reproduced or distributed, in whole or in part, without prior written permission of MCRMA. However, reproduction and distribution, in whole or in part, by non-profit, research or educational institutions for their own use is permitted if proper credit is given, with full citation, and copyright is acknowledged. Any other reproduction or distribution, in whatever form and by whatever media, is expressly prohibited without the prior written consent of MCRMA.

©2020 MCRMA - 106 Ruskin Avenue, Rogerstone, Newport, Gwent NP10 0BD
01633 895633 info@mcrma.co.uk www.mcrma.co.uk

First published 26/05/16: 1st revision 21/11/16: 2nd revision 18/04/18: 3rd revision 21/05/20

MCRMA The Building Envelope Authority' is a registered Collective Trademark of the Metal Cladding and Roofing Manufacturers Association Limited.