

Stud Shear Connectors in Composite Beams that Support Slabs with Profiled Steel Sheeting

Stephen J Hicks, General Manager, Heavy Engineering Research Association—Structural Systems, Auckland City, Manukau, New Zealand; Andrew L Smith, Structural Engineer, Grubb Engineering Corporation, Alberta, Canada.

Contact: stephen.hicks@hera.org.nz

DOI: 10.2749/101686614X13830790993122

Abstract

This paper presents the results from the final phase of a major UK research programme, where an 11,4-m span composite beam and companion push tests were undertaken to investigate the load-slip performance of multiple stud connectors. The tests showed that the resistance of three studs per rib was no better than two studs per rib, thereby indicating that the design equations in BS 5950-3.1 and ANSI/AISC 360-10 were unconservative by up to 45%. As a direct result of this work, an amendment was made to BS 5950-3.1 in 2010.

Although the beam tests demonstrated the ductile performance of studs in current UK-profiled steel sheeting, the problem remained that if new sheeting products were developed, it would be difficult to identify cases when the behaviour was poor unless beam tests were undertaken. In response to this problem, this paper also presents the development of an improved standard push test, which reflects the conditions that exist in a real beam more closely. As opposed to other international investigations, the improved test was calibrated directly against real beam behaviour by considering the load-slip performance of the shear connectors within the three beam tests that were undertaken in the current research programme.

Keywords: composite beams; shear connection; shear connectors; headed studs; profiled steel sheeting; push test; push-out test; push-off test; resistance; reduction factor; ductility; slip capacity; safety; ANSI/AISC 360-10; Eurocode 4; BS 5950-3.1; NZS3404.1; EN 1994-1-1.

Introduction

The forces that occur in the concrete flange of a composite beam are shown in Fig. 1a. The compressive forces F_c , which reduce over the thickness of the concrete flange, are in equilibrium with the tensile forces F_{sf} within the transverse reinforcement and with the longitudinal shear forces F_l in the studs. The forces F_{ten} , resulting from the inclination of the compressive forces F_c at the weld collar of the stud, and F are in equilibrium (the force F leads to transverse bending in the slab). Under constant vertical shear force where $V_l = V_r$, the components F and F_{ten} compensate for each other and, at the interface between the concrete and the top flange of the steel beam, only the shear forces F_l occur. Should

a distributed load q be introduced, the vertical shear forces are affected such that $\Delta V = V_l - V_r = q$. If the distributed load q acts on the concrete flange, as well as the longitudinal shear force F_l , a compression force $q \Delta_l$ exists at the interface between the concrete and the top flange of the steel beam.

The load-slip performance of shear connectors has been historically established from small-scale push specimens of the type shown in Fig. 1b. The internal forces in the push specimen are shown to enable direct comparisons to be made with those in a composite beam. The forces F_l are transferred through the concrete in a similar way as a composite beam (note the recess at the bottom of the slab is optional in the standard test in Eurocode 4²). The moment Pe , resulting from the eccentric load introduction, causes tension in the studs and compression at the interface between the concrete and the flange of the steel section. In the Eurocode 4 standard test, the magnitude of the tension forces in the studs

F_{ten} is therefore affected by frictional forces developing at the base of the slab at the interface between the test slabs and the strong floor μP (where μ is the friction coefficient); if these frictional forces are eliminated, F_{ten} increases, which has been shown to reduce the shear resistance of the studs by approximately 30%.³ Alternatively, some researchers¹ have reduced the tension forces in the studs by modifying the standard test through the introduction of the tension tie Z shown in Fig. 1b.

The characteristic resistance of a stud embedded within a solid concrete slab has been evaluated from push test data and is determined in Eurocode 4, ANSI/AISC 360-10⁴ and NZS 3404.1⁵ by considering the possibility of stud shank failure or crushing of the concrete. In Eurocode 4, the characteristic resistance of a stud is taken to be the smaller of the following two equations:

$$P_{RK} = 0,8A_{sc}f_u \quad (1)$$

or

$$P_{RK} = 0,37A_{sc}\sqrt{f_{ck}E_{cm}} \quad (2)$$

where A_{sc} is the cross-sectional area of the shank of the stud of diameter d , f_u is the ultimate tensile strength of the stud material, f_{ck} is the characteristic cylinder compressive strength of the concrete and E_{cm} is the mean secant modulus of elasticity of the concrete.

As opposed to using Eqs (1) and (2), the “characteristic stud resistances” given in BS 5950-3.1⁶ represent a linear regression line through push test data⁷ and are presented in tabular form as a function of stud diameter/length against characteristic compressive cube strength.

When studs are welded in sheeting with the ribs transverse to the supporting beams, the shear resistance is reduced. To account for this effect, the characteristic resistance is determined by multiplying the resistance of a stud embedded within a solid concrete slab



Peer-reviewed by international experts and accepted for publication by SEI Editorial Board

Paper received: March 4, 2013

Paper accepted: May 1, 2013

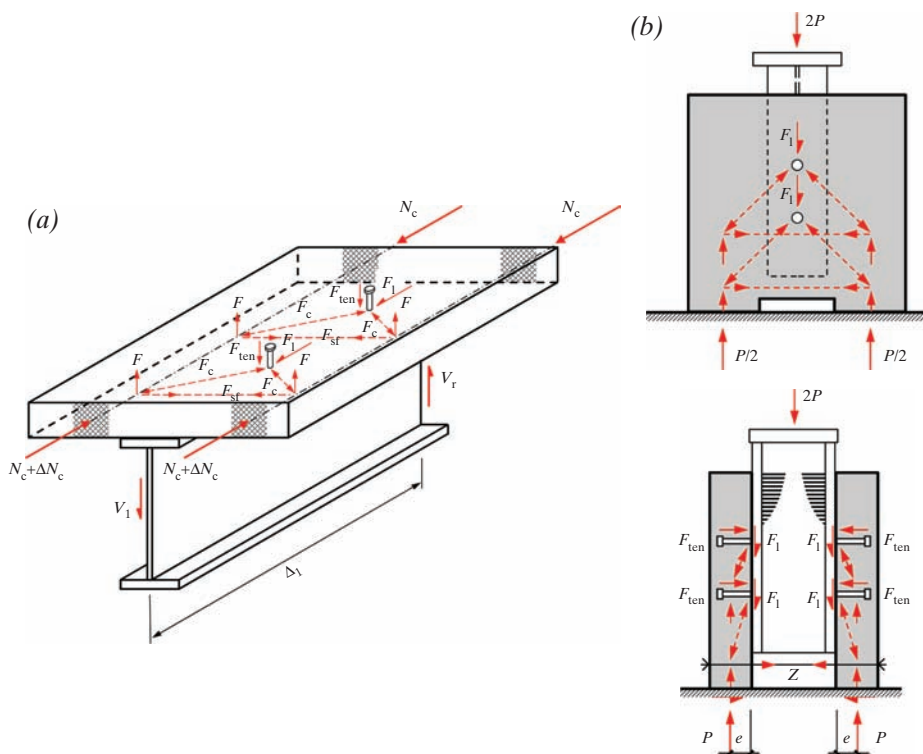

Fig. 1: Internal forces within (a) a composite beam and (b) a push test¹

by a reduction factor k , which has been evaluated from push tests of the type shown in Fig. 1b. For Eurocode 4, the reduction factor is applied to both Eqs (1) and (2) and the smaller value is used in design. Conversely, for ANSI/AISC 360-10, k is only applied to the design equation for stud failure (Eq. (1)), whereas for NZS 3404.1 it is only applied to the design equation for crushing of the concrete (Eq. (2)). According to Eurocode 4, BS 5950-3.1 and NZS 3404.1, the reduction factor for studs welded centrally within a rib is proportional to:

$$k_t = c \sqrt{n_r} (b_0/h_p) \{(h_{sc}/h_p) - 1\} \text{ but } \leq k_{t,max} \quad (3)$$

where c is a calibration factor (in Eurocode 4 and NZS 3404.1 $c = 0,7$ and in BS 5950-3.1 $c = 0,85$), n_r is the number of stud connectors in one rib at a beam intersection, b_0 is the average breadth of the concrete rib for trapezoidal profiles (which is taken as $b_0 = 2e$ in BS 5950-3.1 when studs are

welded in the unfavourable position as shown in Fig. 2c), h_p is the height of the profiled steel sheeting, h_{sc} is the height of the stud and $k_{t,max}$ is the upper limit given in Table 1.

For ANSI/AISC 360-10, the reduction factor for studs welded centrally within a rib is proportional to:

$$k_t = R_g R_p \quad (4)$$

where R_g is the group effect factor ($R_g = 1,0$ for $n_r = 1$; $R_g = 0,85$ for $n_r = 2$; and $R_g = 0,7$ for $n_r \geq 3$) and R_p is the position effect factor (from Fig. 2, $R_p = 0,75$ when $e \geq 50$ mm and $R_p = 0,6$ when $e < 50$ mm).

n_r	Eurocode 4		BS 5950-3.1	NZS 3404.1	BS5950-3.1+A1
	$t \leq 1,0$ mm	$t > 1,0$ mm			
1	0,85	1,0	1,0	1,0	0,82
2	0,70	0,8	0,8	0,8	0,45
≥ 3	—	—	0,6	0,6*	—

* Limited to $n_r = 3$.

Table 1: Upper limits $k_{t,max}$ for the reduction factor k_t for through-deck welded studs

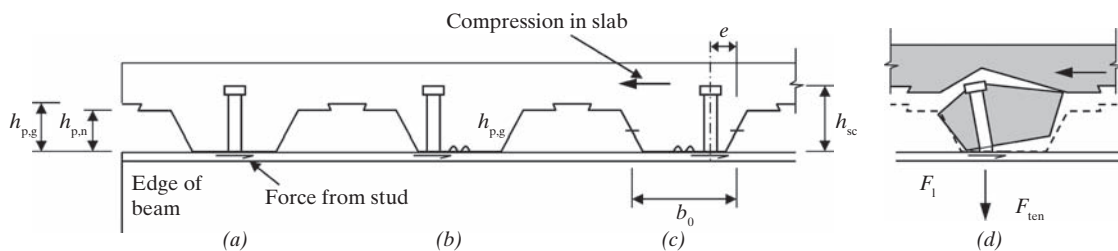

Fig. 2: Dimensions of profiled steel sheeting and studs in the (a) central; (b) favourable; (c) unfavourable position; and (d) concrete pull-out failure

Questions have arisen on the appropriateness of using the reduction factors in Eqs (3) and (4), owing to the fact that the failure mechanisms of studs in profiled steel sheeting are quite different to those experienced in solid slabs, which are described by Eqs (1) and (2); to remedy this situation, attempts have been made to develop mechanical models⁸ but, as yet, the resulting equations have not been adopted by any standards. For example, when push tests are conducted on studs welded favourably or centrally within the ribs of modern trapezoidal sheets (Fig. 2), a typical failure mode known as concrete pull-out occurs.^{9,10} In this case, the whole stud rotates and is pulled out of the slab, carrying with it a wedge-shaped pyramidal portion of concrete (Fig. 2d); in these cases, the axial tension in the stud can be significant, which has been measured in some special test specimens to be in the order of 30% of the longitudinal shear resistance.¹¹ Due to the tension and rotation of the stud, the concrete slab can separate from the profiled steel sheeting relatively early in push tests, which brings into question whether it is entirely appropriate to neglect the compression at the interface between the concrete and the steel section that would occur in a composite beam subjected to a uniformly distributed load (Fig. 1a).

Another key performance characteristic that is evaluated from push tests is the ductility of the shear connectors. The ductility is measured by the slip capacity δ_u , which is defined as the slip where the characteristic resistance P_{Rk} intersects the falling branch of the load-slip curve. The Eurocode 4 rules for partial shear connection are based

on two independent studies.^{12,13} These studies assumed that, in solid concrete slabs and composite slabs using profiled steel sheets prevalent in the 1980s, the characteristic slip capacity of 19 mm diameter studs was approximately $\delta_{uk} = 6$ mm. The required slip was determined from numerical analyses of composite beams using various spans, cross sections and degrees of shear connection. The rules for partial shear connection in Eurocode 4 were limited to situations where the required slip did not exceed 6 mm. Studs were deemed to be “ductile” in those situations.

Push tests in Australia¹⁴ have suggested that studs welded within the ribs of modern trapezoidal profiled steel sheeting possess lower resistance and ductility than those assumed in current standards on composite construction. To address these concerns, tests on two full-scale composite beams together with six companion push tests were undertaken.¹⁵ A variety of shear connector arrangements were investigated, which included (cf. Fig. 2) one stud per rib in the favourable ($n_r = 1F$), central ($n_r = 1C$) and unfavourable position ($n_r = 1U$) and two studs per rib in the favourable position ($n_r = 2F$).

Both beam specimens exhibited excellent ductility with measured slip capacities exceeding the levels assumed in the development of the rules for partial shear connection. Furthermore, the performance of the beams generally supported the UK practice of using the net height of the rib $h_{p,n}$ in Eq. (3). However, for $n_r = 2F$, the characteristic resistance was lower than anticipated, which led to a modified reduction factor formula being proposed.¹⁵ Furthermore, from comparisons between the load-slip curves from the beam tests and the companion push tests, it was shown that any brittleness exhibited in push tests was as a result of a deficiency in the standard push specimen rather than the shear connection.

Although a modified reduction factor was proposed for $n_r = 2F$, it was believed that the performance of the studs was adversely affected by local uplift effects from their longitudinal

spacing in the beam test (corresponding to 677 mm, which is equivalent to $4,8 \times$ overall slab depth). In addition, although BS5950-3.1, ANSI/AISC 360-10 and NZS3404-1 permit $n_r = 3$, the rules appear to be based on limited experimental evidence. To further investigate the performance of $n_r = 2F$ and provide experimental data for $n_r = 3F$, a third full-scale composite beam specimen, together with six companion push tests, was constructed and tested to failure. Furthermore, to address the apparent deficiency that exists in the current standard push specimen, a new test was developed and calibrated against the results from the three beam tests. The remainder of this paper describes this work and its implications on design.

Experimental Investigation

To represent UK practice and provide comparisons with the earlier beam tests, a typical 60 mm deep trapezoidal sheet was fixed perpendicular to the longitudinal axis of the steel I-beam (consisting of a Multideck 60-V2 profile manufactured from S350GD+Z275 material according to BS EN 10326¹⁶). As the limits to the reduction factor formulae in Eurocode 4 reduce for sheet thicknesses $t \leq 1,0$ mm (Table 1), a 0,9-mm-thick sheet was used to ensure that the lowest stud resistance was achieved in the tests (which is the thinnest sheet currently employed in UK construction). The cross section of the sheet was similar to that shown in Fig. 2, with $b_0 = 150$ mm, $h_{p,n} = 60,9$ mm and $h_{p,g} = 69,9$ mm.

The shear connectors consisted of 19 mm diameter \times 100-mm-long headed studs (length-as-welded of approximately 95 mm). Due to the presence of a central stiffener within the rib of the sheet, the studs were through-deck welded in the favourable position with the dimension e in Fig. 2 corresponding

to 110,5 mm. Two stud arrangements were considered in the tests: $n_r = 2F$ with a transverse spacing of 104,6 mm (equivalent to $5,5d$) and $n_r = 3F$ with a transverse spacing of 75,3 mm (equivalent to $4d$). The slab was 140-mm-thick normal-weight concrete and was reinforced with one layer of A193 square mesh fabric, consisting of 7-mm-diameter wires at 200 mm cross centres. The reinforcement was laid directly on the deck (i.e. the top of the studs projected 11 mm above the mesh).

For the beam test specimen, the steel section consisted of a 533 \times 210 \times 82 kg/m UKB using grade S355 steel supplied according to BS EN 10025-2.¹⁷ In a similar manner as the earlier tests,¹⁵ the internal forces were evaluated from strain gauge measurements on the steel beam, which were recorded at cross sections corresponding to the shear connector positions; these were accompanied with horizontally mounted transducers to monitor the slip at the interface between the underside of the slab and the top flange of the steel beam. The geometry of the steel section was measured at each of the 20 instrumented cross sections. The average measured geometrical properties of the UKB section are presented in Table 2.

The stress-strain relationship of the materials was established from a minimum of three tensile coupons taken from the steel section, profiled steel sheeting, studs and the reinforcement, which were tested according to BS EN 10002-1.¹⁸ The average measured material properties are presented in Table 3.

The normal force at each of the instrumented cross sections was evaluated by transforming the measured strains to stresses using the measured stress-strain relationship for the steel, prior to integrating these derived stresses over the measured cross-sectional area of the steel section. By plotting the

Location	Steel section			Profiled steel sheeting	Reinforcement bars
	Top flange	Web	Bottom flange		
Mean yield strength f_{ym} (N/mm ²)	426,98	442,09	424,97	372,40	627,00

Note. Mean ultimate tensile strength of headed studs $f_{um} = 509,28$ N/mm².

Table 3: Average measured steel properties

Height h (mm)	Top flange width b_t (mm)	Bottom flange width b_b (mm)	Web thickness t_w (mm)	Top flange thickness t_{ft} (mm)	Bottom flange thickness t_{fb} (mm)	Root radii r (mm)	Cross-sectional area A (mm ²)
532	208,6	208,4	10,0	12,8	12,9	12,7*	10545,7

*Nominal dimension.

Table 2: Average measured cross-sectional properties for 533 \times 210 \times 82 kg/m UKB

Position	Age, t (days)	Mean cube strength $f_{cm,cube,100}$ (N/mm ²)	Characteristic cube strength $f_{ck,cube}$ (N/mm ²)	Mean cylinder strength f_{cm} (N/mm ²)	Characteristic cylinder strength f_{ck} (N/mm ²)	Mean secant modulus of elasticity E_{cm} (kN/mm ²)
Composite beam specimen 3	10	32,90	28,55*	30,84**	22,84*	19,6***
Companion push tests	13	33,83	29,65*	31,72**	23,72*	19,8****
	14	34,53	30,47*	32,38**	24,38*	19,9****

*Calculated according to EN 1992-1-1.¹⁹

**Based on conversion factors according to Ref. [20].

***Calculated from initial stiffness of composite beam.

****Calculated according to EN 1992-1-1 for variation of modulus of elasticity with time.

Table 4: Measured concrete properties

Test ref.	n_r	$P_{e,1}$ (kN)	$P_{e,2}$ (kN)	$P_{e,3}$ (kN)	P_{Rk} (kN)	δ_{uk} (mm)
MBP02	2	51,24*	51,39*	56,30	46,1	1,7
MBP03	3	36,79*	38,33	38,48	33,1	2,0

*Concrete age 13 days.

Table 5: Characteristic resistance of studs welded in the favourable position (F) evaluated from the standard push test

change in normal force ΔN_c at each of the instrumented cross sections with the corresponding measured slips from the horizontally mounted transducers, the *in situ* load-slip behaviour of the shear connectors was evaluated.

In the interests of providing the lowest degree of shear connection that is permitted by the current standards in order to obtain evidence of slip capacity, a low concrete strength class of C20/25 was specified. The gain in the compressive concrete strength was monitored using $100 \times 100 \times 100$ mm cubes that were stored under cover with the composite beam specimen. A summary of the measured properties are presented in Table 4.

Companion Push Tests

Six nominally identical push specimens were constructed using exactly the same lorry load of concrete that was used in the beam specimen so that direct comparisons of the performance could be made. The push tests consisted of three specimens with $n_r = 2F$ and $n_r = 3F$, respectively.

Concrete pull-out failure occurred in all the tests (Fig. 2d). The shear resistances from each set of tests $P_{e,n}$ are given in Table 5 along with characteristic resistance and slip values calculated in accordance with Annex B of Eurocode 4 (taken as 0,9 times the minimum test value, as the deviation from the mean did not exceed 10%). As can be seen from Table 5, the characteristic slip capacity is lower than the 6 mm value given by Eurocode 4 for “ductile” connectors. It is interesting to

note that the characteristic resistance for $n_r = 2F$ is remarkably consistent with the earlier push tests, where an identical value was evaluated.¹⁵

Composite Beam Specimen 3

The composite beam was simply supported over a span of 11,4 m (Fig. 3) and, in a similar way as the earlier beam tests,¹⁵ the beam was propped at third-points at the wet concrete stage so that the full self-weight load was applied to the shear connection once the props were removed. As well as pre-loading the studs, this construction also ensured that the effects of ponding were minimised to enable a constant slab thickness to be assumed in the back analysis of the test. A total slab width of 2850 mm was provided, which corresponds exactly with the effective width requirements given in current standards of beam span/4. To remove the beneficial effect of compression forces developing at the base of the studs from the hogging bending moments that would occur over a beam in a real building, the loads were conservatively applied directly over the centre-line of the beam to simulate the bending moment from a uniformly distributed load.

As can be seen from Fig. 3, the studs were through-deck welded in the 2F and 3F position on the left- and right-hand side of the beam, respectively.

General Behaviour of the Beam

From the concrete modulus of elasticity E_{cm} given in Table 4, the total shrinkage strain was estimated from BS EN 1992-1-1¹⁹ to be equivalent to a tensile normal force in the concrete of 222 kN. From linear-elastic partial shear connection theory, the shrinkage force transferred by the end group of studs was calculated to be 24 kN. In addition, it is estimated that concrete shrinkage resulted in a mid-span deflection of 4,6 mm.

The props were left in place until the concrete was 6 days old (corresponding to $f_{cm,cube,100} = 28,7$ N/mm²). Once the props were struck, the self-weight load on the composite cross section, which amounted to 96 kN, resulted in a measured mid-span deflection of 7,65 mm (excluding the estimated deflection caused by shrinkage). The end-slips indicated that there was symmetry in the shear connector behaviour, with measured values of 0,070 mm and 0,073 mm at points A and D in Fig. 3, respectively.

The use of plastic theory to predict the bending resistance is limited in most standards to shear spans where the degree of shear connection η is at least 40% ($\eta = n/n_f$, where n is the number of studs provided and n_f is the number of studs required for full shear

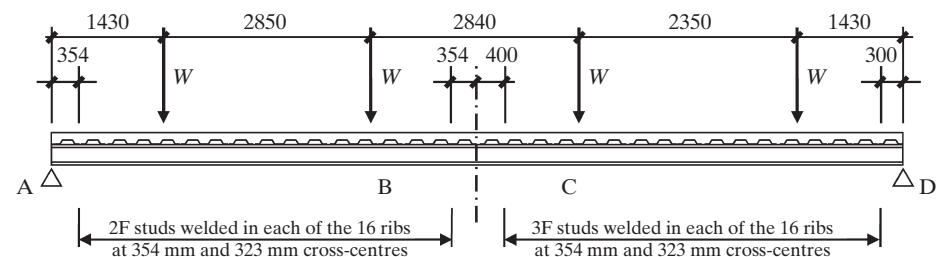

Fig. 3: General arrangement of composite beam test specimen (Units: mm)

n_r	Stud position	$P_{e,min}$ (kN)	P_{Rk} (kN)	δ_{uk} (mm)	Stiffness* k_{sc} (kN/mm)	Eurocode 4 $P_{Rk}/P_{Rk,n}$	ANSI/AISC 360-10 $P_{Rk}/P_{Rk,n}$	BS5950-3.1 $P_{Rk}/P_{Rk,n}$	NZS3404.1 $P_{Rk}/P_{Rk,n}$
1**	F	123	111	9,6	83	2,19 (50,6)	1,38 (80,6)	1,27 (87,3)	1,73 (64,3)
	C	107	96	11,9	31	1,90 (50,6)	1,19 (80,6)	1,10 (87,3)	1,49 (64,3)
	U	89	76***	6,0	46	—	0,94 (80,6)	1,32 (57,6)	—
2	F	65,5	58,9	7,2	109,7	1,20 (49,0)	0,66 (89,3)	0,75 (78,8)	0,99 (59,4)
3	F	64,2	40,2***	6,0	327,2	—	0,55 (73,6)	0,68 (59,1)	0,83 (48,5)

Note. Calculated characteristic resistance values in kN are given in parenthesis

*Stiffness calculated according to Eurocode 4 as $0,7 P_{Rk}/s$, where s is the slip at a load of $0,7 P_{Rk}$

**Composite Beam Specimen 2

***down-rated to achieve characteristic slip capacity of 6 mm

Table 6: Characteristic properties of studs in the favourable (F), central (C) and unfavourable position (U) evaluated from beam tests

connection). From the measured geometry and material strengths presented in Tables 3 and 4, the tensile force in the steel beam is $A_a f_{ym} = 4576$ kN. For $n_r = 2F$ and taking the characteristic resistance of 46,1 kN from Table 5, $n_f = 4576/46,1 = 99$ (following a similar calculation, $n_f = 138$ for $n_r = 3F$). However, in the tests, 12 ribs were available up to the points of maximum moment defined by B and C in Fig. 3, so for $n_r = 2F$, the number of studs provided $n = 2 \times 12 = 24$ and $\eta = 24/99 = 0,24$ (for $n_r = 3F$, $\eta = 3 \times 12/138 = 0,26$). This simple calculation shows that the degree of shear connection provided in the tests was below 40% and implies that failure of the shear connection would occur while the steel beam remained partially elastic. This behaviour was borne out in the test, which was deliberate owing to the fact that the beam test was intended to provide evidence of slip capacity.

Under load, a very ductile failure of the shear connection occurred along AB before the steel beam was fully plastic at B. At the maximum applied load, the bending at point B was 1152,5 kNm at a mid-span deflection of 260 mm (equivalent to span/43). The maximum end slip recorded at point A was 22,6 mm and 12 mm at point D. By preventing additional slip along AB, the beam was subjected to further vertical displacement until a maximum moment of 1156,5 kNm was achieved at C, which corresponded to a mid-span deflection of 329 mm (equivalent to span/35). At this point, an end slip of 20,4 mm was achieved at point D, whereupon the test was terminated owing to concerns over the stability of the test rig from the large curvatures. In a similar way as the companion push tests, concrete pull-out failure was later confirmed in both beam specimens when the concrete slab was carefully excavated around the stud positions (Fig. 2d).

From the load-slip curves evaluated from the beam tests, the character-

istic resistances presented in Table 6 have been taken to be 0,9 times the minimum failure load per stud $P_{e,min}$ according to Eurocode 4 Annex B. For completeness, the earlier results for $n_r = 1$ are also presented¹⁵ (the results for $n_r = 2F$ from the previous beam test are not included, as it was deemed that their performance was adversely affected by uplift from the longitudinal spacing of $4,8 \times$ overall slab depth). Owing to the shape of the load-slip curves for $n_r = 3F$ and $n_r = 1U$

studs, the characteristic resistance has been down-rated in Table 6 in order to satisfy the Eurocode characteristic slip requirements when connectors may be taken to be ductile.

Development of an Improved Push Test

Beam and companion push test load-slip curves for studs with the lowest recorded resistance are presented in Fig. 4. As can be seen from these

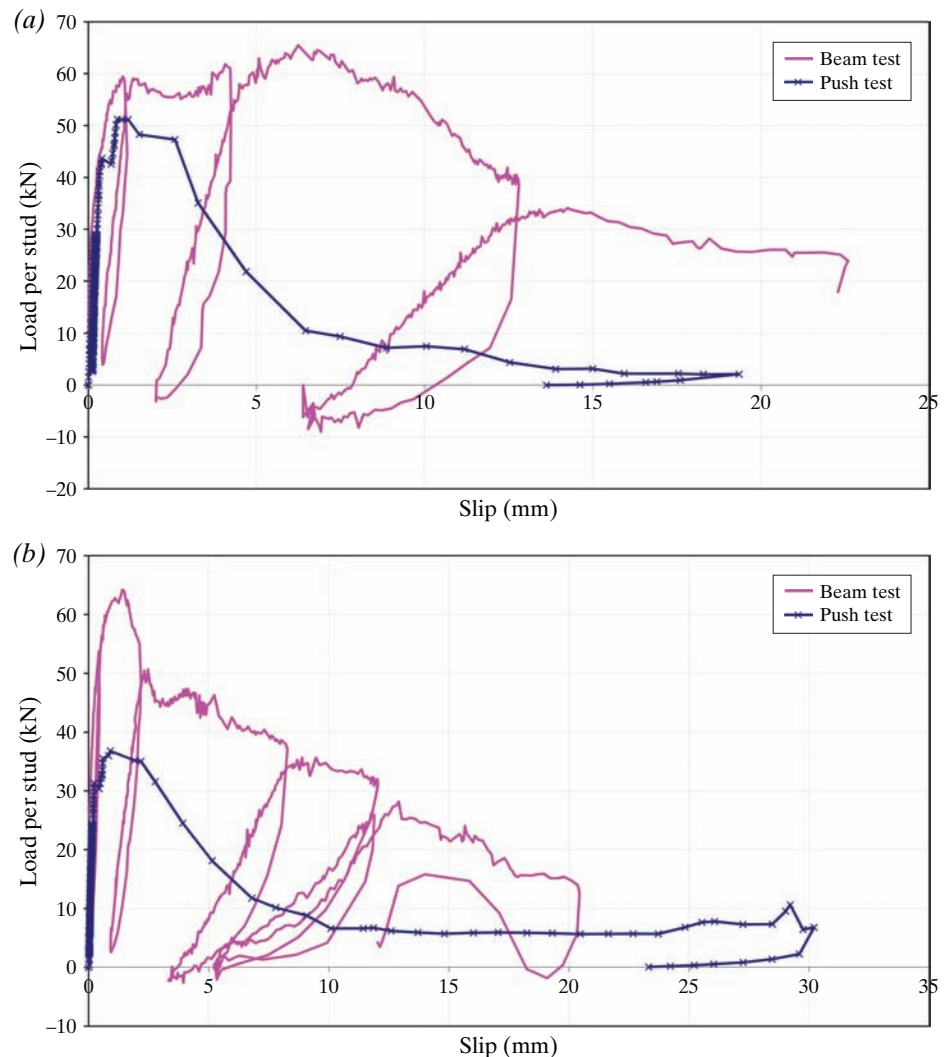

Fig. 4: Load-slip curve for beam test compared to standard push test for (a) $n_r = 2F$ and (b) $n_r = 3F$

plots, there appears to be no similarity in performance of studs in these two types of specimens. The slips measured in the push tests are well below the levels achieved in the beam and, if considered in isolation, would suggest that the studs should not be taken to be “ductile”. These observations were also made in the earlier beam tests for $n_r = 1$ and $n_r = 2$.¹⁵

From comparisons of the load-slip curves, it is clear that any brittleness exhibited in the push test is as a result of a deficiency in the standard specimen rather than the shear connection. However, although the present tests showed that the performance of studs through-deck welded in current trapezoidal sheeting is ductile, the problem remained that, if new floor decks were developed, it would be difficult to identify cases when the behaviour would be brittle unless further beam tests were undertaken. Moreover, although helpful in evaluating the actual load-slip performance of shear connectors, it would be difficult to conduct beam tests in sufficient numbers to investigate the sensitivity of different parameters and evaluate the performance of a design model using structural reliability analysis.

It was felt that the reason for the poor performance in push tests is due to the absence of the compression force at the interface between the concrete and the flange of the steel section, which exists in real composite beams from the floor loading (*Fig. 1a*). Earlier work²¹ attempted to remedy this problem by modifying the push test through the introduction of a normal force, equivalent to 10% of the vertical load, applied directly over the centre-line of the steel section. The results from these tests were compared favourably with the performance of four 9,0 m span companion beam tests and were subsequently used to develop the design rules for stud connectors in the 2010 AISC Specification.⁴ Similarly, the push test was modified in Australia to a single-sided arrangement and tested in the horizontal position.²² In the Australian tests, the normal force was slightly smaller at 5% of the longitudinal shear force but was applied uniformly along the edges of the specimen, thereby applying a hogging moment over the centre-line of the steel section to reflect the loading conditions on two 8,05-m span companion beam tests.

In the present work, it was decided to draw inspiration from the earlier North American and Australian modifica-

tions and develop a new test, which better reflects the conditions that exist in a real beam. As good-quality load-slip data existed from the present composite beam tests, the new test could be calibrated against this performance. However, rather than developing a completely new specimen, it was proposed to modify the standard specimen given in Annex B of Eurocode 4, in the interest of developing a relationship with historical push test resistances. Also, although a single-sided arrangement was considered, this was disregarded due to concerns that such an arrangement would prevent the redistribution of load from one test slab to the other, which occurs in the existing standard specimen.²³ Finally, due to the possibility of different friction coefficients at the base of the test slabs affecting the repeatability of the tests² (*Fig. 1b*), it was decided to develop a self-contained rig that could be disassembled and erected in different locations without the need of a strong floor.

The improved push rig is shown in *Fig. 5*. The loading system consists of two vertical jacks applying the longitudinal shear force, accompanied with two horizontal jacks applying a lateral force, which is uniformly distributed over the face of the test slabs through a grillage of UC sections. A total of 14 specimens were constructed from a single concrete mix using the same details that had been provided in the previous beam tests with $n_r = 1F$ and $n_r = 2F$. They were tested with the following levels of normal force (taken as a proportion of the longitudinal force): 0%, 4%, 8%, 12% and 16%. The load-slip curves for these tests are presented in *Fig. 6* and compared against those mea-

sured in the beam tests. It was considered that the results with a 12% lateral load provided the closest match with the load-slip behaviour from the beam test. While it might be argued that this lateral load does not impose the exact stress conditions within the studs in the beam tests, it is felt that the improved push rig delivers more representative performance of studs in a beam, while still maintaining the simplicity of the traditional push test.

A further two tests with a lateral load of 12% were conducted to evaluate the characteristic values for $n_r = 1F$ and $n_r = 2F$ (which were subsequently given the test reference A1D and A2DY, respectively). In a similar way as the earlier tests, taking the characteristic value as 0,9 times the minimum measured, the following properties were evaluated: $P_{Rk} = 101,2$ kN and $\delta_{lk} = 10,2$ mm for $n_r = 1F$; and $P_{Rk} = 63,8$ kN and $\delta_{lk} = 8,7$ mm for $n_r = 2F$. By comparing these values with those presented in *Table 6*, the improved push rig delivered performance properties in good agreement with the beam tests. The improved push rig was subsequently used to investigate the effect of a number of key variables on the load-slip arrangement of headed stud connectors. Further details on specimens A1D and A2DY and the subsequent parametric investigation are reported in Ref. [24].

Due to the favourable comparisons with the three full-scale beams presented in this paper, as well as similar levels of lateral force being found to be appropriate in the earlier North American and Australian research programmes (which used different concrete strength classes, trapezoidal profiled steel sheeting geometries, etc.), it is recommended

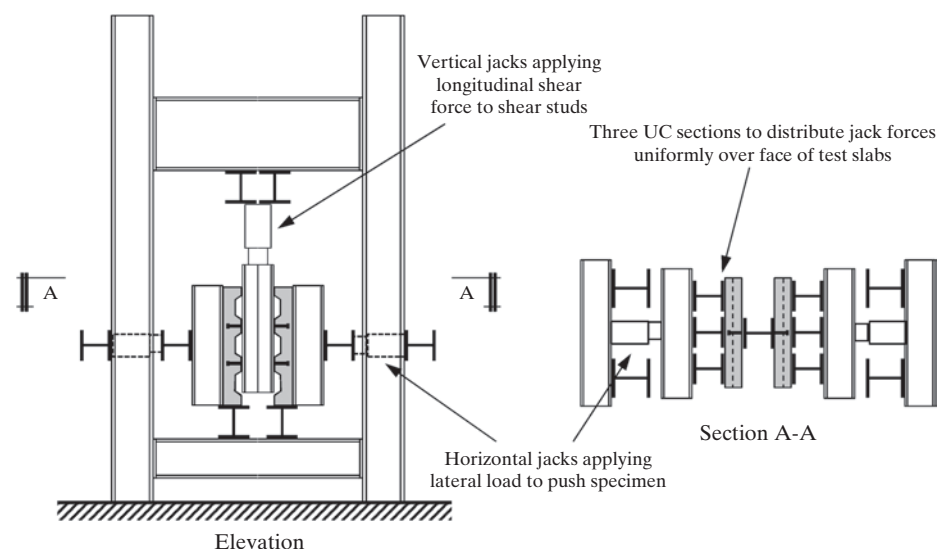

Fig. 5: Improved push test rig

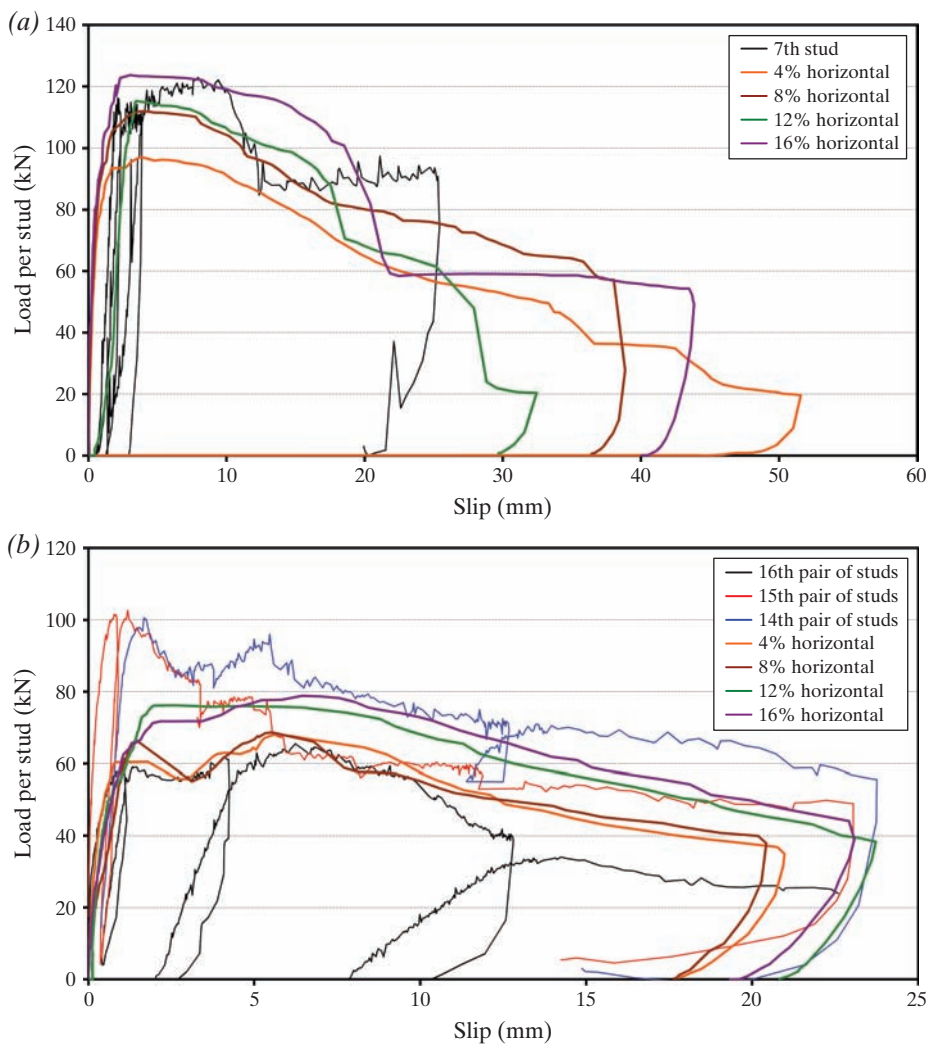

Fig. 6: Comparison of load-slip behaviour for the new improved test with that measured in beam tests for (a) $n_r = 1F$ and (b) $n_r = 2F$

that the improved push test may be used with confidence for the common case when the loading is applied to the concrete slab of a composite beam. For special cases when the load is applied directly to the steel beam (such as may be encountered in crane beams), the tensile forces applied to the shear connectors will be significant; in these cases, it may be more appropriate to reduce the lateral load from 12% to zero, which has been verified by other investigators from tests on composite beams and companion push tests.²⁵

Discussion

To examine the performance of the current standards with the beam tests, predictions of the characteristic stud resistance according to Eurocode 4, ANSI/AISC 360-10, BS 5950-3.1 and NZS3404-1 are presented in Table 6. By adopting the current UK practice of using $h_{p,n}$ in Eq. (3) (Fig. 2), the predicted characteristic stud resistances for the net height of the sheet $P_{Rk,n}$

are based on the characteristic material properties evaluated from measurements given in Table 4.

As can be seen from Table 6, the characteristic resistance for studs in the 1F, 1C and 1U position compare well with the BS5950-3.1 predictions; however, they become unconservative for studs in the 2F and 3F position (by 25% and 32%, respectively). Similarly, the ANSI/AISC predictions compare favourably for 1F and 1C studs, but become unconservative by 34% for 2F studs and by 45% for 3F studs; however, for this standard, all the predictions are based on stud shank failure, which was not borne out in the tests. For Eurocode 4, the predictions are on the safe side for $n_r = 2$ but appear to be overly conservative for studs in the 1F, 1C and 1U position. Finally, the NZS 3404 predictions compare well with $n_r = 2$ but are conservative for $n_r = 1$ and unconservative for $n_r = 3$.

Equation (3) assumes that the reduction of resistance of studs in profiled

steel sheeting is proportional to $1/\sqrt{n_r}$. By considering Table 6, the reduction to the characteristic resistances measured in the beam tests is $58,9/111 = 0,53$ for $n_r = 2$ and $40,2/111 = 0,36$ for $n_r = 3$. This simple calculation clearly shows that the assumption that the resistance is proportional to $1/\sqrt{n_r}$ is inappropriate. Moreover, when considering the resistance of the shear connection per rib, the resistance of $n_r = 2$ is 6% greater than $n_r = 1$ (i.e. $2 \times 0,53 - 1 = 6\%$), whereas the resistance of $n_r = 3$ is only 8% greater than $n_r = 1$ (i.e. $3 \times 0,36 - 1 = 8\%$). This calculation clearly shows that there is no benefit in providing more than $n_r = 2$, which supports the Eurocode 4 reduction factor formula limit. This finding, in part, led to the amendment given in BS 5950-3.1+A1.²⁶ In this standard, the variables in Eq. (3) are as follows (see final column of Table 1 for $k_{t,max}$): $c = 0,63\sqrt{n_r}$ for $n_r = 1$; $c = 0,34\sqrt{n_r}$ for $n_r = 2$ and no guidance is given for $n_r = 3$.

Conclusions

Full-scale composite beam and companion push tests have been undertaken with trapezoidal profiled steel sheeting. Propped construction, together with other unfavourable combinations of variables, was adopted to demonstrate the slip capacity that can be achieved in a beam, together with the level of safety that exists in current design standards. All specimens exhibited excellent ductility with slip capacities exceeding the levels assumed in the development of the rules for partial shear connection in Eurocode 4.

The performance of the beams generally supports the UK practice of using the net height of the rib $h_{p,n}$ in the reduction factor formulae. However, for two and three studs per rib, the performance in the beam test was lower than anticipated by ANSI/AISC 360-10, BS5950-3.1 and NZS 3404.1. The results also demonstrate that there is no further improvement in resistance when providing three studs per rib, and this arrangement should be used with caution when using plastic design. These findings, in part, led to the amendment given in BS 5950-3.1+A1.

From comparisons of the load-slip curves between the beam tests and the companion push tests, it is clear that any brittleness exhibited in the push test is as a result of a deficiency in the standard push specimen rather than the shear connection. To

remedy this situation, an improved push test has been developed, which has been calibrated against real beam behaviour.

Acknowledgements

This paper is dedicated to Mr. Clifford Dyer, who sadly passed away in February 2012 and was responsible for the formation of the Metal Cladding and Roofing Manufacturers Association (MCRMA). Financial support for this investigation was provided by the Floor/Deck Group of the MCRMA, Tata Steel Construction Services and Development together with Tata Steel Strip Products UK. The authors wish to thank the help and assistance of Dr. R.E. McConnel, Mr. M.R. Touhey and the technical staff of Cambridge University Engineering Department whose expertise ensured the success of the testing programme. The authors also thank Prof. R.P. Johnson of University of Warwick for his support and advice, together with Dr. J.W. Rackham and Dr. W.I. Simms, formerly of The Steel Construction Institute.

References

- [1] Roik K, Hanswille G. Zur Dauerfestigkeit von Kopfbolzendübeln bei Verbundträgern. *Der Bauingenieur* 1987; **62**: 273–285.
- [2] EN 1994-1-1: 2004. *Eurocode 4: Design of Composite Steel and Concrete Structures – Part 1-1: General Rules and Rules for Buildings*, European Committee for Standardization: Brussels.
- [3] Hicks SJ, McConnel RE. The shear resistance of headed studs used with profiled steel sheeting. In *Composite Construction in Steel and Concrete III*, Buckner CD, Shahrooz BM (eds), ASCE: New York, 1997; 325–338.
- [4] American Institute of Steel Construction. *ANSI/AISC 360-10. Specification for Structural Steel Buildings*, American Institute of Steel Construction: Chicago, 2010.
- [5] NZS3404-1:1997. *Steel Structures Standard. Part 1, Incorporating Amendment No. 1 and 2*, Standards New Zealand: Wellington.
- [6] BS 5950-3.1: 1990. *Structural Use of Steelwork in Buildings: Part 3: Section 3.1: Code of Practice for Design of Simple and Continuous Composite Beams*, British Standards Institution: London, 1990.
- [7] Menzies JB. CP 117 and shear connectors in steel-concrete composite beams made with normal-density or lightweight concrete. *Struct. Eng.* 1971; **49**(3): 137–154.
- [8] Johnson RP. Calibration of resistance of shear connectors in troughs of profiled sheeting. *Proc. Instn. Civ. Eng., Struct. Bldg.* 2008; **161**: 117–126.
- [9] Hawkins NM, Mitchell D. Seismic response of composite shear connections. *J. Struct. Eng.* 1984; **110**(9): 2120–2136.
- [10] Lloyd RM, Wright HD. Shear connection between composite slabs and steel beams. *J. Construct. Steel Res.* 1990; **15**: 255–285.
- [11] van der Sanden PGFJ. *The behaviour of a headed stud connection in a 'new' push test including a ribbed slab, Tests: Main report*. BKO Report 95-15, Eindhoven, 1996.
- [12] Johnson RP, Molenstra N. Partial shear connection in composite beams for buildings. *Proc. Inst. Civ. Eng.* 1991; **91**(Part 2): 679–704.
- [13] Aribert J-M. *Dimensionnement de poutres mixtes en connection partielle*. Mixed Structures Including New Materials. IABSE Symposium, Brussels, *International Association for Bridge and Structural Engineering Reports*, 1990; 60: 215–220.
- [14] Patrick M. *Composite beam shear connection design and detailing practices for Australian steel decks*, Report CCTR-CBSC-001-04, University of Western Sydney, 2004; 15.
- [15] Hicks S. Strength and ductility of headed stud connectors welded in modern profiled steel sheeting. *Struct. Eng. Int.* 2009; **4**: 415–419.
- [16] BS EN 10326: 2004. Continuously hot-dip coated strip and sheet of structural steels. *Technical Delivery Conditions*, British Standards Institution: London.
- [17] BS EN 10025-2: 2004 Hot rolled products of structural steels. *Technical Delivery Conditions for Non-Alloy Structural Steels*, British Standards Institution: London.
- [18] BS EN 10002-1: 2001. *Metallic Materials – Tensile Testing – Part 1: Method of Test at Ambient Temperature*, British Standards Institution: London.
- [19] EN 1992-1-1:2004. *Eurocode 2: Design of Concrete Structures, Part 1-1*, European Committee for Standardization: Brussels.
- [20] Stark JWB, Van Hove BWEM. *Statistical analysis of push-out tests on stud connectors in composite steel and concrete structures, Part 2: Solid Concrete Slabs*. TNO report BI-91-163, Delft, 1991.
- [21] Easterling WS, Gibbings DR, Murray TM. Strength of shear studs in steel deck on composite beams and joists. *Eng. J. AISC, Second Quarter* 1993; 44–55.
- [22] Bradford MA, Filonov A, Hogan TJ, Ranzi G, Uy B. Strength and ductility of shear connection in composite T-beams. *8th International Conference on Steel, Space & Composite Structures*, Kuala Lumpur, Malaysia, 15–17 May, 2006; 15–26.
- [23] Johnson RP. *Designers' Guide to Eurocode 4: Design of Composite Steel and Concrete Structures*, 2nd edn, Thomas Telford: London, 2012; 257.
- [24] Smith AL, Couchman GH. Strength and ductility of headed stud connectors in profiled steel sheeting. *J. Construct. Steel Res.* **66**: 2010; 748–754.
- [25] Ernst S, Bridge RQ, Wheeler A. Correlation of beam tests with pushout tests in steel-concrete composite beams. *J. Struct. Eng.* 2010; **136**(2): 183–192.
- [26] BS 5950-3.1: 1990+A1. *Structural Use of Steelwork in Buildings: Part 3: Section 3.1: Code of Practice for Design of Simple and Continuous Composite Beams*, British Standards Institution: London, 2010.



Being a Member of **IABSE** brings you together...

Companies,

increase their access to visibility within the worldwide structural engineering community, and to new information, new perspectives and new contacts.

..tell your colleague.

www.iabse.org