



Guidance document GD 26

May 2016

Amended November 2016

**ALUMINIUM FABRICATIONS AND FLASHINGS:
BEST PRACTICE DESIGN AND FIXING GUIDE**

(This document is currently under review)

1.0 INTRODUCTION

The Metal Cladding and Roofing Manufacturers Association (MCRMA) has produced guidance document GD 26 to accompany BS 5427:2016 section 7.1. Both GD 26 and BS 5427:2016: section 7.1 demonstrate best practice guidance on the design of aluminium fabrications and flashings, including fasteners and sealants.

The guidance in GD 26 illustrates the issues and suggests solutions. These solutions are indicative; both BS 5427:2016: section 7.1 and the design and installation advice of the manufacturers of the fabrications, fasteners and sealants used for a project take precedence.

The thermal movement range used in GD 26 is a worst case scenario and shows the extremes of what may be needed. However, a project should be designed for the particular circumstances of that project, using the principles of GD 26 and BS 5427.

This will include fabrication material, material colour, the length of fabrication, location of fixed point, temperature at installation, temperature range, insulation and substrate. The design should consider whether dead fixing or flexible fixing is appropriate for the application.

Project specific design could indicate lower movement leading to more choice of suitable fasteners, washers and sealant materials. For all projects, the fastener and sealant manufacturers should be consulted to obtain the correct specifications for the applications.

Aluminium fabrications are subject to research sponsored by the MCRMA and GD 26 will be updated as and when new data becomes available.

All aluminium roofing and cladding systems rely upon mechanical fasteners to secure the system to the structure, and sealants to seal junctions. The importance of the correct selection and application of fasteners and sealants is often underestimated by designers and left to the experience of the fixer on site. This approach can lead to early and unexpected failures which can be costly to rectify.

Aluminium expands and contracts due to temperature change. Forces generated are large and will cause damage to structures and fasteners unless they are managed and allowed to occur in a controlled manner. The movement has to be accommodated by both fasteners and sealants.

A fabrication may not be the primary weatherproof layer and can have an internal waterproof drained secondary flashing or membrane. In this respect, the aesthetic fabrication is sealed but acts as a form of rainscreen.

For the purposes of this guide, aluminium fabrications are defined as sections with a material thickness of 1mm or over. These tend to be regarded as aesthetic; items such as bullnose and fascia etc. Flashings are defined as sections less than 1mm thick and generally less aesthetic and more functional in nature such as roof ridges and hips etc.

Thin flashing sections of 0.9mm aluminium are generally used as flashings in conjunction with aluminium profiled sheeting of the same colour or as part of an aluminium standing seam roof. The latter have bespoke detailing specific to the standing seam system with specific system supports for flashings. Flashings are specifically addressed in section 2.0

In all instances, it is essential to make reference to the system supplier or manufacturer and to involve the fastener and sealant manufacturers in the flashing joint design and fastener specification.

2.0 FLASHINGS

0.9mm aluminium flashings are relatively more flexible than thicker fabrications. They undergo the same stresses and strains, but mitigate some of the effect by flexing. When fixing flashings, the following guidance applies:

- Follow the specific fixing regime stipulated by the roof system manufacturer.
- Fix ridge/hip flashings at typically maximum 400mm centres.
- Fix verges at typically 500mm centres maximum.
- Allow laps and butt strap joints to float.
- Follow the principles for fastener and sealant design in sections 4.0 and 5.0.

3.0 DESIGN

3.1 Material thickness

The minimum thickness recommended for aluminium is 0.9mm. Where appearance is of prime importance, for example on fascias, due attention should be paid to consider and specify thicker aluminium and post-painting. Curved fascias may need to be up to 3mm in thickness with welded fabrications which have been surface dressed and factory post-painted. This tends to give a neater appearance than lock-formed thinner materials.

As a general guide, the unstiffened or unsupported widths and material gauges in Table 1 can be used. The thicker material option should be adopted where high aesthetic standards are required and the wider limit where appearance is not critical (behind parapets, for example). The mid-range should be suitable for most building purposes.

In all cases, a suitable lined and levelled support system is required. Aluminium fabrications should not be fixed to light gauge roof or wall sheets. The fabrication should be specified in 3 series aluminium as this provides the best flatness.

Gauge mm	Unstiffened width mm
0.9	125-200
1.2	175-300
1.5	225-450
2.0	275-550
3.0	325-650

Table 1 Material gauges for unstiffened widths

In all cases, aluminium fabrications should be isolated from galvanised steel supports using suitable self-adhesive PVC tape to prevent bi-metallic corrosion.

3.2 Thermal movement

A 2014 research paper, *Factors Affecting the Accommodation of Thermal Movement in Halter Based Aluminium Standing Seam Systems* carried out by David Cottrell at the Department of Architecture and Civil Engineering, the University of Bath, suggests that aluminium sections will expand and contract by up to 2mm per linear metre.

This is based on the extremes of temperature of 78°C attained by stucco-embossed unpainted aluminium and RAL 7015 slate grey pre-painted aluminium. Other colours attained lesser maximum temperatures, refer to Table 2.

In design it is safest to adopt the worst case temperature extreme of 78°C. The minimum temperature is taken as -28°C and the temperature at installation of -5°C to +25°C. For example:

$$\text{Maximum rate of expansion} = 23.3 \times 10^{-6} \times (78 - (-5)) = 1.93 \text{mm/m}$$

$$\text{Maximum rate of contraction} = 23.3 \times 10^{-6} \times (-28 - (+25)) = 1.23 \text{mm/m}$$

In round figures, allow +2mm/-1.5mm per m.

Colour	Max temp °C
White (RAL 9010)	55
Metallic silver (RAL 9006)	62
Light grey (RAL 7035)	64
Light green (RAL 6027)	69
Pigeon blue (RAL 5014)	74
Plain aluminium	78
Slate grey (RAL 7015)	78

Table 2 Maximum temperatures

The restrained stress exerted by thermal effects is related to the cross sectional area and temperature change. Stress = $\alpha.E.\Delta T$

α = the coefficient of expansion for aluminium = $23.3 \times 10^{-6} / ^\circ\text{C}$

E = Young's modulus = 70000N/mm^2

ΔT = temperature change = $78 - (-5) = 83^\circ\text{C}$

A = cross sectional area of a section or fabrication = girth x thickness, mm^2

$$\alpha.E.\Delta T = 135.373\text{N/mm}^2$$

If a section is 2mm thick and 1000mm girth, the force generated is:-

$$\alpha.E.\Delta T.A = 135.373 \times 2 \times 1000 = 270746\text{N} = 270.7\text{kN} = 27594\text{kg} = 27.6\text{tonnes!!}$$

That is, the forces are massive and cannot be restrained; they have to be allowed to give somewhere.

Designers and installers must take this movement and force into account in order to avoid unwanted flexing, buckling and even tearing of the material. Unless managed, the stresses will load the fasteners and supporting structure to a point where fixing failures will occur or flashings tear.

Daily expansion and contraction of an assembly can 'work' some fasteners resulting in a slow but steady un-winding of the threads and fabrications/flashings becoming loose or detaching from the sub structure or adjoining materials.

3.3 Fastener position: Fixed point/floating point method

For most applications the tried and tested fixed point / floating point method of fastening aluminium components will accommodate movement provided that care is taken to detail and install correctly.

The fixer should install one 'fixed point' or 'dead fix' within the length of each section. This could be a single fastener or a set of fasteners grouped together.

3.3.1 Fixed point

Typically, the fixed point can be at one end of each section or at the mid-point position. The fasteners can be conventional self-drilling fasteners with washers or suitably specified rivets.

The fixing will be solid with no movement capability. Where the fixed point comprises more than a single fastener, care must be taken to set them across the girth at right angles to the length of the section. Preferably, the fixed point is in the centre of each section so that movement can happen outwards in both directions.

NB: There can only be a single fixed point for each metal section.

3.3.2 Floating point

Subsequent fixings will be allowed to 'float' using, for example, an oversized or slotted hole, or sliding clip to allow the aluminium to slide across the fixing - in this way all thermal movement will happen along each metal section from the fixed point towards and past the floating fixing(s) - see Figure 1.

Central fixed point (preferred)

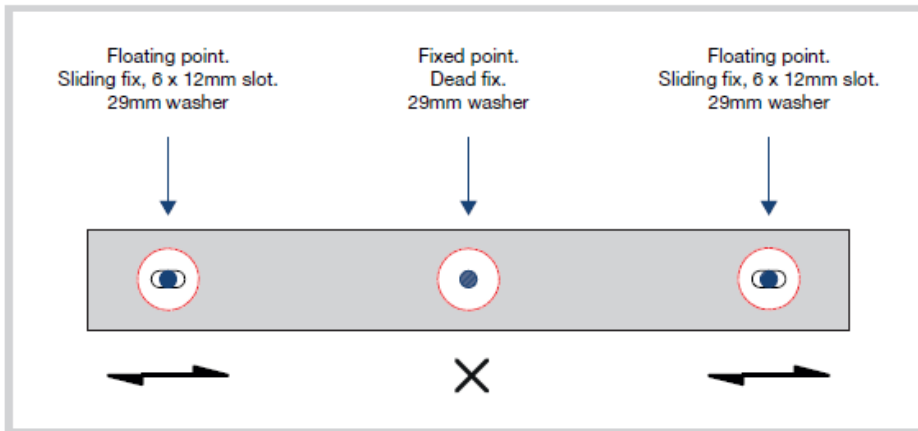

Fixed point one end

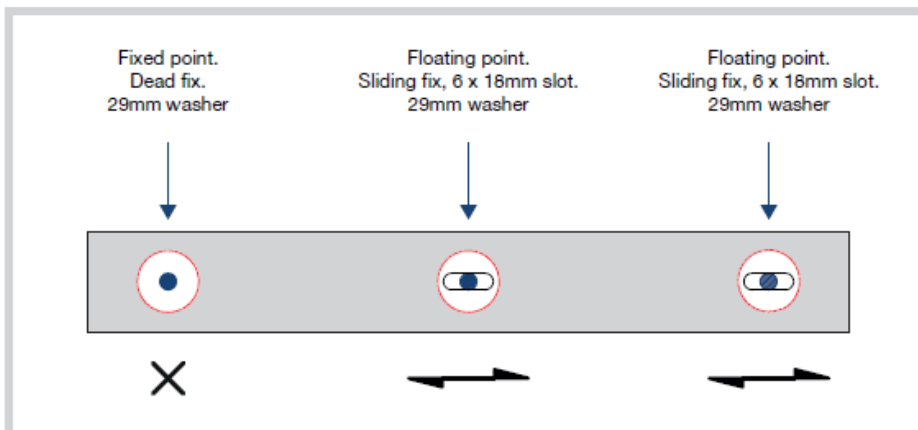

Figure 1: Examples of fixed point and floating point

Clearly, adequate arrangements must be made to manage the expansion and contraction at the end of each section as well as at fasteners.

In each 3m fabricated section with a 78⁰C rise in temperature the **fixed point at one end** and a 6mm diameter fastener central to a slot, the slot should be $6 + (2 \times (2 \times 3)) = 18\text{mm}$ long. The expansion at the flashing end would be $2 \times 3 = 6\text{mm}$ and the expansion gap at a butt strap would need to be 6mm at minimum (allow 10mm).

This calculation assumes that adjacent flashings or fabrications follow a consistent LHS or RHS rule for the fixed end position.

In each 3m fabricated section with a 78⁰C rise in temperature the **fixed point at the mid-point** and a 6mm diameter fastener central to a slot, the slot should be $6 + (2 \times (2 \times 1.5)) = 12\text{mm}$ long, the end expansion $2 \times 1.5 = 3\text{mm}$ at each end and the gap at a butt strap = $2 \times 3 = 6\text{mm}$ at minimum (allow 10mm).

From this it is obvious that mid fixed points in each 3m section put a lot less movement stress into junctions between fabrications and are advised as best practice.

In all cases, fasteners should be located at the centre of the expansion slot. See overleaf for examples of fabrication junctions

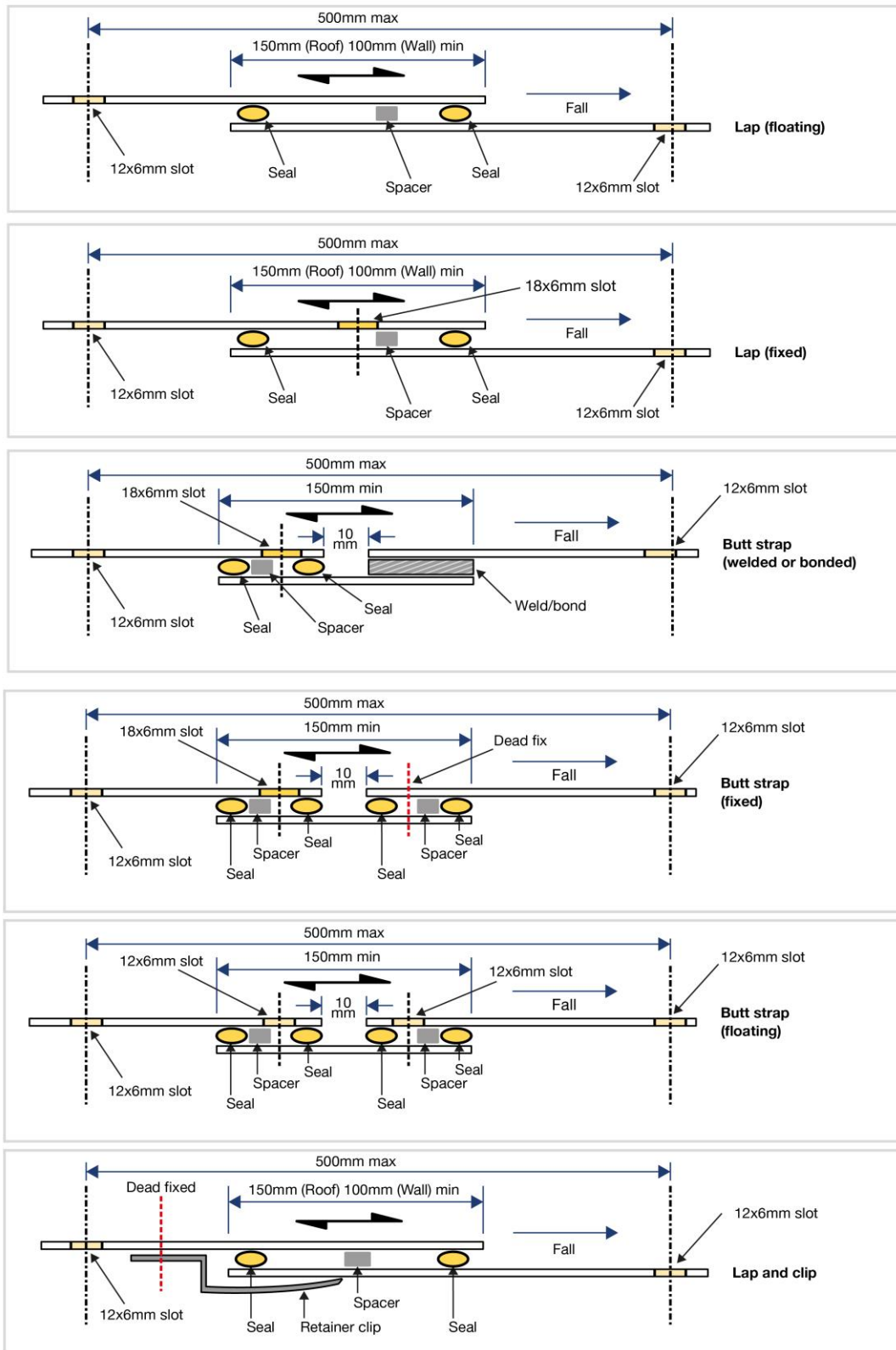

Note: Slot size based on 6mm diameter fastener, 3 metre long fabrications with dead fix at mid-point and +/- 2mm maximum movement at fabrication ends.

Figure 2: Styles of fabrication junctions

A 3m aluminium fabrication will expand and contract by max +/-3mm at each end if it has a fixed point at its mid-point.

Where the junction has a fixing to the end of each meeting fabrication, the movement at that fixing would be max $3+6+3 = 12\text{mm}$ (assuming a 6mm diameter fastener).

Where the junction has just one fastener, for example with a welded or bonded butt strap or with a straight forward lap, the movement at that fixing would be max $(3+3)+6+(3+3) = 18\text{mm}$. The weld or bond becomes a dead fix and movement is transferred to the opposite fastener, increasing the movement required.

Note that thermal movement occurs in every direction from the fixed point, ie the girth will also expand and contract. For a narrow fabrication of, for example, 200mm girth this should not cause problems. On the other hand, for a very large bullnose of 1m or greater girth, the fastener slotted holes must take into account the possibility of expansion/contraction across the girth, in addition to movement along the length. Slots of 7mm x 12mm allow some movement.

3.4 Fabrication junctions

Joints in 0.9mm open section fabrications should be lapped and joints in closed section fabrications that do not nest should be butt strapped. Material greater than 0.9mm thick should always involve butt straps, preferably factory bonded to one side. Typical joint details are shown in Figure 2.

The temperature at installation also has an effect. In midwinter when the aluminium is cold it will be at its shortest and warm weather expansion has to be allowed for. In midsummer on a hot day the metal will be at its longest and cold weather contraction must be allowed for instead. If in doubt, and to avoid site errors, then design for the maximum extent and place fasteners centrally within a slot. If oversize circular holes are used, a centring tool should be used to ensure the fastener is at the centre or bulls eye position.

3.5 Secondary weatherproofing

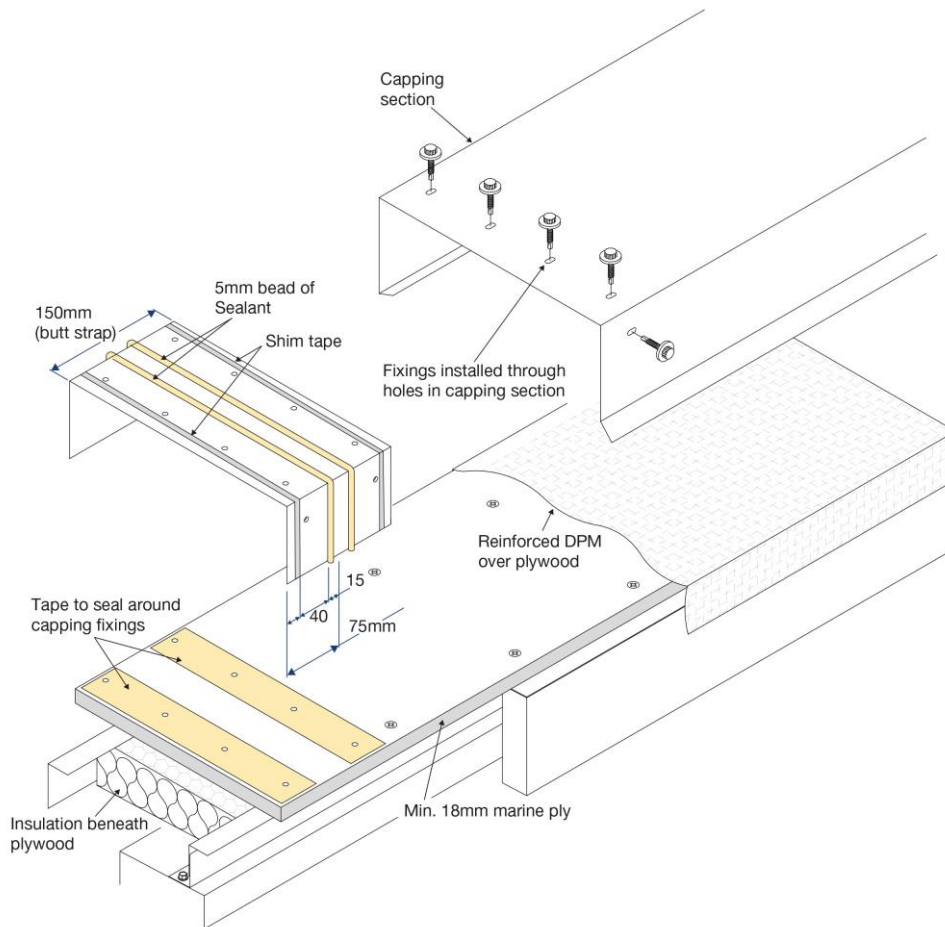

Figure 3 Typical aluminium capping systems with secondary weathering membrane

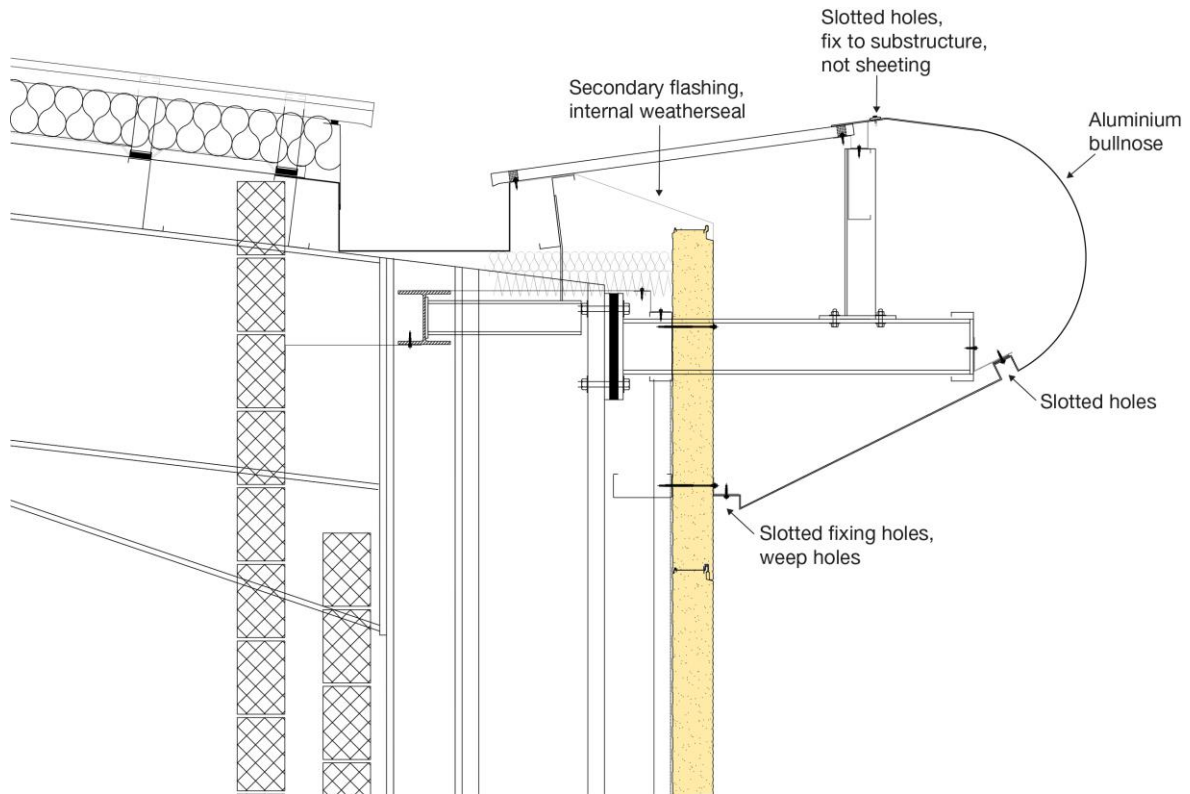

Figure 4 Bullnose showing connection to the structure

Experience has shown that the performance demanded of sealants in confined joint sizes in aluminium fabrications is very demanding and that the use of a secondary weatherproofing layer on the underside of the fabrication is prudent. This primarily concerns aesthetic fabrications thicker than 1mm (bullnose/ fascia/ verge)

Junctions and connections should be properly sealed as described in this guidance document, but with the installation of a secondary weathering layer within the detail so that, should the junction wear and age, there is a second barrier to prevent the ingress of water.

This can take the form of a secondary metal flashing or supported membrane. This layer should drain externally via weep holes suitably positioned in the outer aesthetic fabrication.

4.0 FASTENERS

The fastener manufacturer should be consulted to obtain the correct fastener specification for the application.

Fasteners join two thin materials together and must be purpose-designed for the application. These are generally either self-drilling stitcher screws or proprietary stainless steel sealed rivets with integral colour heads and bonded sealing washers. Separate colour caps do not have long-term durability. Stitcher screws in some applications can lead to a bulky appearance.

Fasteners across a lap or butt joint need to clamp and hold the two surfaces together and also firmly compress, but not squeeze out the sealant. This requires them to be installed at 75-100mm centres to avoid opening up under the load. Fabrications must be well secured to the structure or sheeting and maximum centres of 500mm are recommended.

All fasteners that are used for fixing aluminium should be made from austenitic stainless steel (A2 or A4 grade).

4.1 Examples of incorrectly specified fasteners



Figure 5: Consequence of no movement allowance: fastener backing out of a capping



Figure 6: Consequence of no movement allowance: fastener shape demonstrates the high thermal movement loads developed. Carbon steel fastener corroding, stainless steel advised for flashings

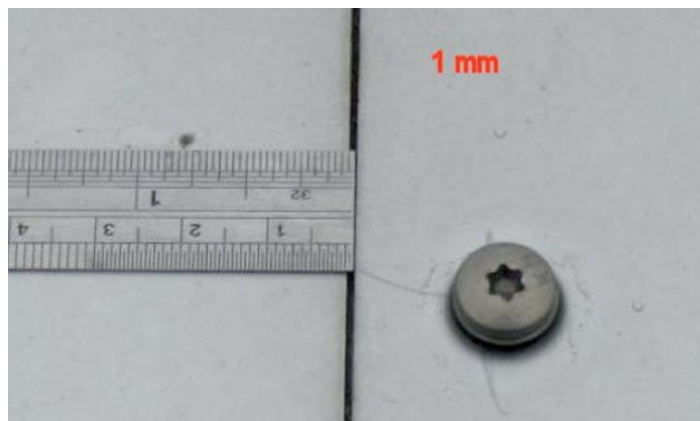

Figure 7: Lack of expansion allowance

A correctly set fastener, with the sealing washer element deployed as the designer intended, will be less at risk of backing out than a heavily over-tightened fastener that has had the sealing element crushed down to almost nothing. Over-driving (see figure 8) due to fixers removing depth control features from screw guns must be avoided. A correctly set tool will resolve many of the fixing problems experienced.



Figure 8: Consequence of no movement allowance: fastener backing out of a capping – deformed washer indicates heavily overdriven fastener

To fix aluminium to thin flexible materials use all stainless steel rivets. Fasteners should incorporate 29mm diameter washers for applications with oversize holes or slots. Only the outer section of flashings and fabrications should incorporate oversize holes or slots.

Do not use oversize holes or slots in the inner section of the flashing or the sub structure; the correct pilot hole size is important when rivets are used. A slot must be smooth sided to avoid snagging and should preferably be factory punched.

5.0 SEALANTS

The sealant manufacturer should be consulted to obtain the correct sealant specification for the application.

The selection and specification of a sealant and spacer strip for a project should be carried out with the input from the sealant manufacturer to ensure that the sealant materials chosen and joint dimensions are suitable for the application and anticipated movement.

Note that sealant manufacturers refer to the dimension between surfaces as the width and the dimension across the lap as the depth (see Figure 9).

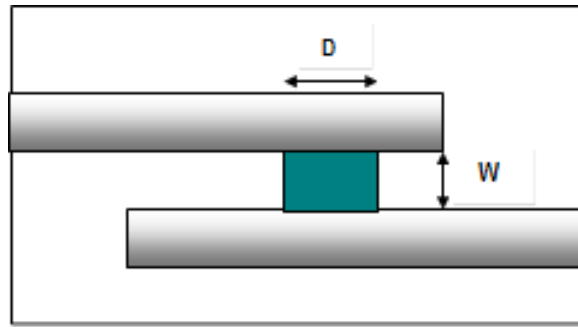

W = Width of sealant (often referred to as the thickness)

D = Depth of sealant

Figure 9: Sealant dimensions

See sections 3.2 and 3.3 for the maximum movement anticipated throughout a year. The Movement Accommodation Factor (MAF) is a measure of a sealant's ability to accommodate the movement of a joint. Using the method laid out in BS 6213 the MAF can be calculated as follows:

$$\text{MAF}\% = \frac{\text{Total Movement Expected} \times 100}{\text{Minimum Joint Width}}$$

When the MAF has been calculated the joint design should then be considered and the sealant manufacturer consulted for exact recommendations.

Designing correctly and then making the sealant joint to the design is a key factor in obtaining a reliable and durable weather seal.

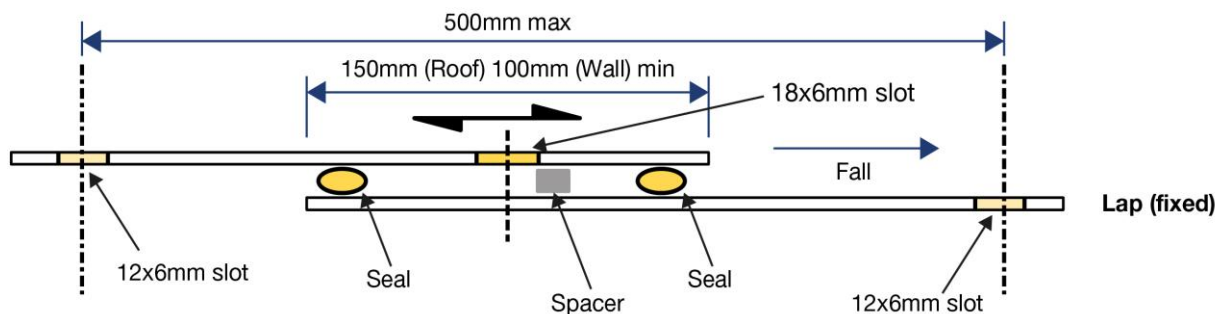

Note: Each maximum 3m section should preferably include a primary fixing (dead fix) to structure at the central mid length position

Figure 10: How to achieve a reliable and durable weather seal

Simply laying a line of wet sealant onto the two metal surfaces and then fixing everything together as tightly as possible will result in the bulk of the sealant being squeezed out of the joint leaving only a thin film behind. Clearly when movement occurs, sealant failure and leakage will follow.

To prevent wet sealant from squeezing out of the joint during assembly, incorporate a medium density compressed foam tape or shimmed preformed butyl strip sealant bonded to one face of the joint, alongside the sealant bead.

This acts as a spacer, preventing over-compression of the sealant and subsequent reduction in the bead thickness as the adjoining fasteners are tightened (see Figure 11).

The sealant manufacturer should always be consulted for compatible and appropriate sealants.

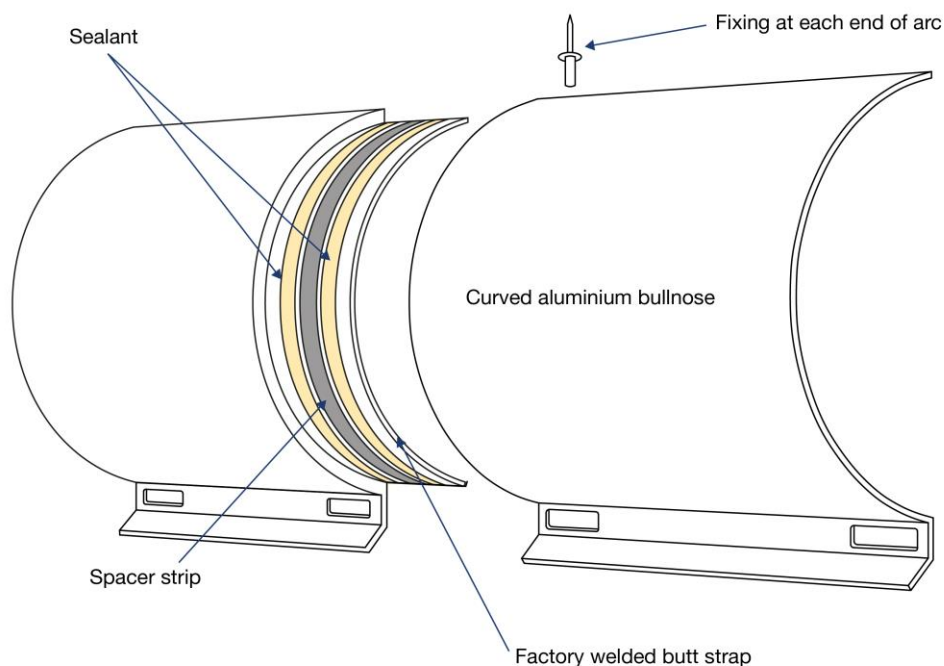

Note: Slots are 12mm x 6mm; 3mm rad rounded ends

Figure 11: Welded butt strap on aluminium bullnose

6.0 TOOLS

There are five sets of tools necessary to carry out fabrications work:

Fabrication work	Suitable tools
Cutting	Saw, nibbler, shear head snips etc
Hole forming	Drill, punch etc
Measuring	Tape, rule, set square, pencil
Fastening	Riveter, screw gun etc
Shaping	Hammer, wide nosed pliers etc

Table 3: Tool requirements

Where electrical tools are used, they must be suitable for 110V site systems and fitted with safety plugs. Battery powered tools can give good service but may be limited by the charge capacity (always carry a charged spare). All electrical tools must be regularly checked and tagged in accordance with the Electrical Regulations.

Repairs to electrical equipment must be carried out by trained personnel only. Cutting blades, tips edges etc. must be kept sharp and clean. Aluminium is easy to cut, being softer than steel, but it can also tear and deform if blunt tools are used.

Certain tools, especially cutting and hole forming tools, require the use of adequate personal protection equipment such as goggles or face mask, ear defenders, gloves etc.

An extensive range of tools is available and the tools selected will depend generally on the preference of the user. Certain tasks may mean that special proprietary tools must be used. Whatever the case, the tool must be fit for purpose; the misuse of tools can be both costly and dangerous.

When cutting and drilling, it is good and safe practice to remove sharp edges and burrs. Grinding tools must not be used for cutting because they produce greater burrs and coating damage than shears or cutting blades.

With power cutting, the operator should consider the problem of noise and ensure that he and others in close proximity use ear protection.

When drilling, it is good practice to use a neoprene sealed washer at the chuck face of the drill to avoid drill damage to the fabrication. Care must be taken when applying force to a drill as sudden penetration may result in fabrication indentations. It is also good practice to apply duct tape at the position of drill holes to prevent the drill bit slipping across the pre-painted surfaces, and the materials should be well supported and swarf must always be removed. Alternatively pre-punched holes should be used.

Cutting tools should be guided along straight edges for the best finish. A marked cutting line should be drawn when using a jig saw. Cables must be clear of any cutting areas. A good cut can be achieved by cutting bulk waste away with power tools and, if required, finishing the work with hand snips or gilbows.

Aluminium is a relatively soft material, and threaded fasteners can easily be overdriven, resulting in stripped threads and a failed fixing. Care must be taken to avoid too much pressure during installation which can result in damage.

Rivets are installed by lever arm riveting tools or power riveters. Lazy tongs should never be used because they work by an operator adopting a 'punching' action, which can lead to fabrication indentation and local damage.

High performance battery powered riveting tools are also available. They can set large numbers of rivets on one charge and retain the used mandrels in a carrier. No matter what the tool used, the sudden fracture of a rivet mandrel can have disastrous results on the finished appearance of a fabrication.

7.0 GOOD HOUSEKEEPING

- Materials must be stored off the ground preferably undercover and secured against the wind.
- Protect against trapped moisture and do not store near to access ways.
- Avoid impact damage during fixing, especially from riveting tools.
- Do not twist fabrications and avoid dragging sections over each other.
- Ensure that the correct section is in the correct place and take care in handling sharp edges. Do not force sections into shape especially at folds or weld lines.
- Do not walk on fabrications, either in storage or when fixed, and store away from lines of foot traffic.
- Notify the main contractor that walking or standing on finished fabrications is to be avoided.
- When working on a fabrication on an aluminium roof, work from a board to avoid over-deflecting the roof sheet or damaging coatings.
- Provide boarding for foot traffic in work areas, provide edge protection and provide warning signs around fragile areas, rooflights etc.
- Clear drill swarf and rivet mandrels as work progresses, do not allow steel swarf to get wet.
- Do not store cardboard boxes of fasteners on roofs and only have enough fasteners for the job in the work area.
- Dispose of any fabrication off-cuts, clear work area as work progresses and protect work from any follow-on trades, especially wet trades.
- Store tools safely when not in use.

8.0 SUMMARY

- Aluminium fabrications and flashings are an assembly of the aluminium sections, sealants and fasteners.
- An aluminium fabrication (bullnose, fascia) should be designed as a 'rainscreen' with a secondary weatherproof internal flashing/membrane.
- Aluminium fabrications and flashings will undergo thermal expansion and contraction.
- Fabrications and flashings should be no longer than 3m in lengths and mid-section fixed points are preferable to minimise the effects of expansion and contraction.
- Fasteners, other than those used to create a fixed point, must accommodate movement in the form of an oversize hole or slot in the outer section.
- Sealants must accommodate movement.
- Involve both the fastener manufacturer and sealant manufacturer in the design and materials specification for flashing joints.
- Show the flashing fixed points, fasteners and sealants in the installation drawings (materials, dimensions, locations, spacings etc).

Adoption by industry of the guidelines outlined in this document will lead to better and more consistent standards of metal roofing and cladding construction.

MCRMA member companies can advise on the suitability and performance of materials, systems and assemblies to ensure that aluminium fabrications and flashings are calculated properly and specified accordingly. In addition, design information can be obtained from any of the independent roofing and cladding inspectors featured on the MCRMA web site at www.mcrma.co.uk

REFERENCES

BS 6213:2000+A1:2010 *Guide to selection of constructional sealants*

Cottrell David *Factors Affecting the Accommodation of Thermal Movement in Halter Based Aluminium Standing Seam Systems* (www.cibse.org)

ISO 11600:2001 *Building construction -- Jointing products -- Classification and requirements for sealants*

DISCLAIMER

Whilst the information contained in this publication is believed to be correct at the time of publication, the Metal Cladding and Roofing Manufacturers Association Limited and its member companies cannot be held responsible for any errors or inaccuracies and, in particular, the specification for any application must be checked with the individual manufacturer concerned for a given installation. System manufacturer guidance takes precedence for their specific systems.

Information provided by the MCRMA or contained within publications and articles which are made available in any form (mechanical, electronic, photocopying or otherwise) cannot be used or cited as a means of ensuring that a material, product, system or assembly is compliant with Building Regulations.

All rights reserved. The material may not be reproduced or distributed, in whole or in part, without prior written permission of MCRMA. However, reproduction and distribution, in whole or in part, by non-profit, research or educational institutions for their own use is permitted if proper credit is given, with full citation, and copyright is acknowledged. Any other reproduction or distribution, in whatever form and by whatever media, is expressly prohibited without the prior written consent of MCRMA.

©2016 MCRMA - 106 Ruskin Avenue, Rogerstone, Newport, Gwent NP10 0BD
01633 895633 info@mcrma.co.uk www.mcrma.co.uk

First published 26/05/16 Amended 21/11/16