FIRE DESIGN OF STEEL SHEET CLAD EXTERNAL WALLS FOR BUILDING

CONSTRUCTION PERFORMANCE STANDARDS AND DESIGN

**THIS DOCUMENT IS NO LONGER IN PRINT AND IS INCLUDED ON THE WEB SITE FOR
REFERENCE ONLY**

PLEASE REFER TO AN MCRMA MEMBER FOR UP TO DATE INFORMATION

THE METAL CLADDING & ROOFING MANUFACTURERS ASSOCIATION



1.0 Introduction

CONTENTS

	Page
1.0 Introduction	
2.0 The anatomy of fire	1
3.0 Tabulation of regulations	2
4.0 Material tests relevant to growth stages of a fire	2
5.0 Constructional requirements in addition to those of section 4	5
6.0 The functional approach to regulations	6
7.0 The fire resistance test	7
8.0 Consideration of fire test criteria	9
9.0 Review of basic design objectives	10
10.0 Fire engineering	12
11.0 Design considerations for an external wall	14
12.0 Corner detailing	25
13.0 Survey of important constructional detail	26
14.0 Detailed recommendations for fire testing	27
15.0 Assessment and Appraisal	28
16.0 Definitions	29
17.0 References	30
18.0 Technical data sheets	30

- 1.1 The use of profiled steel cladding sheets, insulated on the building side and finished accordingly is common in external wall construction for a wide range of building types.
- 1.2 In certain situations the walls so constructed are required to provide for fire protection and in these cases specific building regulations concerned with fire safety have to be complied with.
- 1.3 Currently there are a number of profiled steel sheet systems available and each one constitutes a proprietary design but there is sufficient similarity in the designs to develop generic solutions based on current knowledge from fire testing and fire experience.
- 1.4 This publication has therefore been prepared as an authoritative guide on external wall design utilising profiled steel sheets with the objective of establishing the basic design as meeting the requirements of the regulations thus obviating the need for repetitive testing.
- 1.5 However, where any design is beyond the scope given in this document recourse to validation of performance by testing or by assessment is necessary.

2.0 The anatomy of fire

- 2.1 A typical building fire with conventional contents as opposed to flammable liquid as a spillage or explosion will generally follow the scenario of fire growth to "flashover", followed by full fire development to involve the contents and eventual decline as the combustibles are consumed - unless controlled at some stage by active means such as sprinklers or by fire fighting operations.
- 2.2 In terms of temperature rise in the building the relationship with time can be pictorially presented as shown in Figure 1.

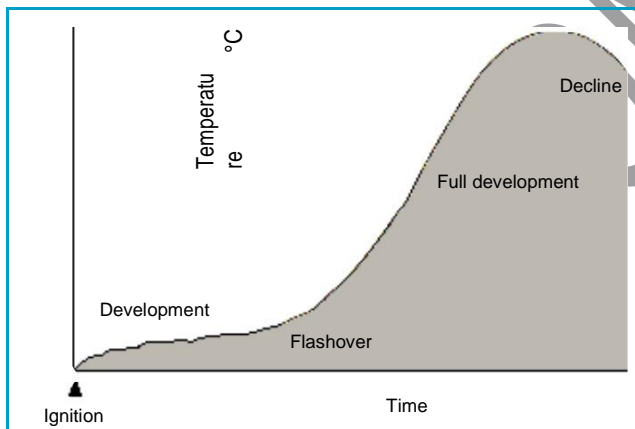

Fig. 1

- 2.3 "Flashover" is when all of the combustibles in the fire compartment or building become involved and is associated with the transition from a smoky contained fire with little flame to the spontaneous ignition of combustibles in a rapid sequence with flame emission from openings on ingress of air, rapid gas expansion and high temperatures.
- 2.4 The possibility of life being sustained in the fire area post "flashover" is minimal.
- 2.5 From first ignition to "flashover" the geometry and design of the building or fire compartment is very significant but dominant is the nature, quantity, distribution and properties of the contents as well as the properties of the wall, ceiling and roof linings.
- 2.6 Whilst the nature of the contents cannot be controlled particularly in industrial and storage buildings, control can be exercised in respect of building finishes as a means of limiting as far as possible the rate of fire growth as this has a direct bearing on the potential for escape.
- 2.7 The importance of early alarm and provision of protected escape routes are fundamental to life safety.
- 2.8 In respect of escape during the growth stage of the fire, the wall and ceiling finishes in terms of their flame spread properties are relevant; the associated properties of heat release, smoke emission and toxic gas generation are also critically important.
- 2.9 It is accepted that in many fire situations the burning characteristics of the contents are totally dominant over those of the wall and ceiling linings.
- 2.10 Regulations seek to control surface finishes and lining materials as a means of reducing as far as practical the rate of fire growth as related to life safety and escape.
- 2.11 Post "flashover" the severity and duration of the fire will primarily depend on the nature of the combustible contents, their quantity and distribution, the extent of surface area for heat emission and fire transfer, the building or fire compartment geometry and ventilation, the ability of the structure to contain the fire, the effectiveness of "in-built" active fire protection systems and Fire Brigade attendance.
- 2.12 Regulations seek to contain a fire outbreak to the area of initiation by creating special fire compartments and ensuring that the building or crucial parts of the building remain structurally stable.
- 2.13 They also seek to reduce the potential of fire spread between buildings by the failure of external walls, and by roof ignition and fire penetration to immediately adjacent buildings as a consequence of heat radiation.



4.0 Material tests relevant to growth stages of a fire

- 2.14 The regulatory concept is therefore "fire containment" except that fire venting through a roof is considered generally advantageous (there are specific exceptions to this) because the risk of fire spread to adjacent buildings, given that control is exercised in the construction materials, is considered minimal and fire venting relieves the fire pressures on the containing constructions and allows maximum smoke, gas and heat release.
- 2.15 The regulations to which the above refers are those prepared by government and are predominantly formulated to provide for life safety, this applying to both inside and outside the building on fire.
- 2.16 The regulations to which this publication refers do not directly reflect a financial consideration of fire in terms of property and contents loss and consequential loss. These are aspects which are primarily of insurance interest.

3.0 Tabulation of regulations

1. Building Regulations 1991 incorporating the Approved Document B.
2. The Building Standards (Scotland) Regulations 1990 incorporating the Technical Standards.

- 4.1 The test methods are fully described in British Standard publications.
- 4.2 These Standards do not set the requirements of acceptability but provide a means of assessment of fire property and a system of expressing the performance achieved.
- 4.3 The Standards are subject to periodic revision in respect of the methodology etc. but in due course the test methods will change according to the requirements of European harmonisation.
- 4.4 There may not be a direct means of transposing the data from the existing British Standards test methods to any new European test, but research on an international level continues to progress the situation.
- 4.5 The test methods referred to in the Regulatory Documents identified in 3.0 (Approved Document B and Technical Standards) are:
1. British Standard 476 part 7: 1971 or 1987 - Surface Spread of Flame Test.
 2. British Standard 476 part 6: 1981 or 1989 - Fire Propagation Test.
- 4.6 A brief description of the test methods is given as follows:
1. BS476: PART 7: 1971/1987
 - (a) The apparatus is a nominal 1 metre x 1 metre source of intense radiant heat set in the vertical plane, against which a sample of the lining material is placed so as to be subjected to a radiation incident on the surface of intensity decreasing from one end of the sample to the other end.
 - (b) Pilot ignition is provided at the hottest end for one minute.
 - (c) A recording is made of the establishment of a flame front and the progression of the flame front over the surface, at a specific reference line normally drawn on the sample.



- (d) The test is solely concerned with the progression of the flame front and does not take account of, or record quantitatively, heat emission, smoke and toxic gas emission etc.
- (e) Linings for ceilings are tested in the vertical plane as for wall linings.
- (f) The test is carried out on the wall or ceiling lining system to embrace the substrate for any surface finish. In certain cases the complete composite of a system has to be tested as core materials etc. may be influential in the classification.
- (g) The results are expressed as a classification number according to the flame progression over the surface.
- (h) Class 1 is the highest classification which reflects the best performance in test and Class 4 is the lowest performance. Class 2 and 3 are intermediate.

2. BS476: PART 6: 1981/1989

- (a) The fundamental difference between the Part 6 and Part 7 test methods is that any heat release from the material or system is contained within the Pt 6 apparatus and judgement is made on this.
- (b) The apparatus basically comprises a bench top size non-combustible box with gas jets and electric element devices contained within it.
- (c) An inlet air vent is provided and a chimney and cowl is set into the top of the box.
- (d) Thermocouples are introduced into the gas stream emerging from the cowl.

- (e) One face of the box is removable so that the non-combustible face can be replaced with a sample of the material or system being examined.
- (f) The apparatus is "calibrated" using the non-combustible removable face with a controlled heat input to achieve a defined time/temperature graph for the exhaust gases, before proceeding to the sample investigation.
- (g) The sample is placed in the position of the removable non-combustible face and with the same heat input via the gas jets and electric elements a further temperature/time graph for the gases emerging from the cowl is obtained.
- (h) By comparison of the two graphs a judgement of the heat potential of the material or system can be made. This is expressed as an index of performance I.
- (i) The index of performance, which has no unit of identification, is the sum of 3 sub-indices i_1 , i_2 , i_3 which reflect the heat potential at precise stages during the test.

Therefore:

$$I = i_1 + i_2 + i_3$$

- 4.7 The regulations through the respective Approved Document and Technical Standards identify Class 1 and Class 3 and also Class 0.
- 4.8 Class 0 is a regulatory term and can be defined as being either:
 - (a) Composed of material of limited combustibility (see para 5.4 et seq) (England & Wales) or non-combustible (Scotland)
 - or
 - (b) A Class 1 material or system which in the BS476: Part 6 test provides an index of performance I not greater than 12 and a sub index i_1 not greater than 6.



- 4.9 Internally within the building the requirement for the wall or ceiling is either Class 1, Class 3 or Class 0 dependent on the use of the building, the compartment size and relation with means of escape.
- 4.10 All protected shafts have to comply with Class 0.
- 4.11 Externally the weathering surface of the wall either has no requirement imposed or has to comply with Class 0 or a modified Class 0 as referred to in 4.12 dependent on the usage of the building, the height of the building and the relation of the wall with the boundary.
- 4.12 In certain circumstances an acceptance standard of a performance index I of not greater than 20 with no reference to the sub-indices is specified, this being a relaxation from Class 0.
- 4.13 In general terms with the Approved Document B any building which has a wall within 1m of the relevant boundary would require the wall surface to comply with Class 0 for the full height.
- 4.14 For all buildings, other than those which are for assembly or recreational use and more than one storey, which are less than 20m in height and 1m or more from the relevant boundary, no control is exercised on the surfaces.
- 4.15 Where the above building is more than 20m in height the surfaces up to 20m may be the relaxed Class 0 referred to in 4.12 (i.e. a surface which has an index of performance I, not greater than 20), with Class 0 for the surfaces above the 20m height to the full height of the building.
- 4.16 In buildings which are specifically for assembly or recreational use which are more than one storey and 1m or more from the relevant boundary, the relaxed Class 0 requirement (refer to 4.12) applies up to a height of 10m with a specific requirement that any wall surface above a roof of a lower portion of the building used by the public also has to be the relaxed Class 0 for 10m above the line of the roof of this lower portion.
- 4.17 In accordance with the Technical Standards, for building which are 15m or less in height, surfaces of walls less than 1m from the boundary require Class 0 but for walls which are more than 1m from the boundary no control is exercised.
- 4.18 For buildings which are more than 15m in height Class 0 is required for walls less than 1m from the boundary and also for walls 1m or more from the boundary except any surface less than 15m may be the relaxed Class 0 standard (refer 4.12).
- 4.19 Normally the performance of materials in the surface spread of flame and fire propagation test cannot be reliably assessed and recourse to testing is necessary.
- 4.20 In many cases a single specimen can be tested instead of a full test and such exploratory test coupled with an authoritative opinion in the form of an Assessment (an expression of opinion by a qualified body) may suffice for regulatory purposes.
- 4.21 Steel sheet is non-combustible as determined by test in accordance with BS476: Part 4: 1970.
- 4.22 Thin combustible films applied to a thin gauge steel substrate can generally meet the requirements of Class 0 and do not present a hazard but no definitive statement can be made as the performance in test will be entirely dependent on the chemical formulation of the film.



5.0 Constructional requirements in addition to those of section 4.0

- 5.1 The tests referred to in section 4.0 are principally concerned with the characteristics of the surfacing materials but with due regard to the nature and contribution of the substrate and any backing or insulating material.
- 5.2 Whilst Class 1 or Class 0 may be achieved, this does not necessarily indicate that such materials will not contribute to the fire condition as materials of organic content may be considered as a backing or insulating infill to the wall construction.
- 5.3 In a fully developed fire such materials may be of significance.
- 5.4 The regulations via the Approved Document B and Technical Standards specify that in identifiable situations the wall has to be constructed of materials of "limited combustibility", although combustible surfacing materials may be used provided there is compliance with Class 1 or Class 0 etc. as appropriate.
- 5.5 A material which is non-combustible in accordance with BS476: Part 4: 1970 automatically complies with the requirements of limited combustibility in accordance with BS476: Part II: 1982.
- 5.6 BS476: Part II adopts the methodology of BS476: Part 4 by subjecting a sample to a furnace environment of 750°C with measurement of the sample core temperature and rise in furnace temperature whilst the sample is in the furnace with the procedure continuing until stable conditions have been achieved.
- 5.7 The criteria of sample flaming and temperature rise for non-combustibility apply to limited combustibility but using a different methodology in calculating the results.
- 5.8 Steel sheet is non-combustible.
- 5.9 Insulating infills formed of glass wool and crushed rock or blast furnace slag wool, with resin binders are normally either non-combustible or of limited combustibility and may therefore be generally used without restriction provided the required fire resistance in the structure, if applicable, can be achieved.
- 5.10 The identification of the external wall components in terms of surface spread of flame, fire propagation and combustibility performance provides no indication of the fire resistance of the assembled wall.
- 5.11 In general terms, in accordance with the Approved Document B, any building with a storey at more than 15m above ground level would require the insulation infill in the external wall to be of limited combustibility.
- 5.12 There is a relaxation to this where combustible facings to the core material are present, which specifies that the core must be non-combustible and not less than 8mm thick with the facings not more than 0.5mm and combustible provided that where a flame spread requirement applies, such composite has to comply.
- 5.13 In general terms, in accordance with the Technical Standards the requirement is for non-combustible construction except in an external wall on or within 1m of the boundary, in a house or shared residential accommodation where the wall may be of combustible structural frame design with external cladding which has a non-combustible external surface and an internal lining of Class 1 minimum.



6.0 The functional approach to regulations

- 6.1 The Building Regulations 1991 and the Building Standards (Scotland) Regulations 1990 are functional in their approach to structural fire protection and external walls.
- 6.2 This represents the major and fundamental change in recently issued amended regulations.
- 6.3 In broad terms, the functional requirement is that the building should be stable in fire and the external walls should offer adequate resistance to the spread of fire over the surfaces and from one building to another, having regard to the height, use and position of the building.
- 6.4 The Approved Document B to the Building Regulations 1991 and the Technical Standards to the Building Standards (Scotland) Regulations 1990 set down procedures which can be followed as a means of complying with the regulations.
- 6.5 The Approved Document B is not a regulation in itself but a means of satisfying the functional regulation. There is no obligation to follow the recommendations of the Approved Document if there is an alternative way which can be justified. The Technical Standards to the Regulations Scotland are mandatory and do not, therefore, directly correspond with the Approved Document in terms of status. However, the Technical Standards include deemed-to-satisfy provisions which relate to the Approved Document and these can be relaxed in the same way given a satisfactory case being established.

- 6.6 The functional approach to regulations has permitted the broader science of fire engineering to be accepted.
- 6.7 The diagram Figure 2 demonstrates in broad terms the regulatory rationale.
- 6.8 The functional approach requires that the building is adequately stable and more usually this is considered to apply to the structural frame and its ability to resist collapse under imposed loads.
- 6.9 However, the criterion of stability within the context of the functional approach has been extended under certain conditions to embrace the stability of walling systems in fire even though they do not perform a building structural functional or are required to provide fire containment or fire resistance.
- 6.10 In following a functional approach it is necessary to consider the wall within the context of the building under the fire condition and also to address the complex significance of the area of the wall involved, particularly the height.
- 6.11 There are a number of aspects, including dimension, that the Fire Resistance test of BS476: Part 20 et seq does not embrace, although additional data to that specifically necessary for Fire Resistance judgement, can be obtained in test and used for design guidance.
- 6.12 To obtain the necessary additional data a Fire Resistance Test has to be structured according to a defined strategy.

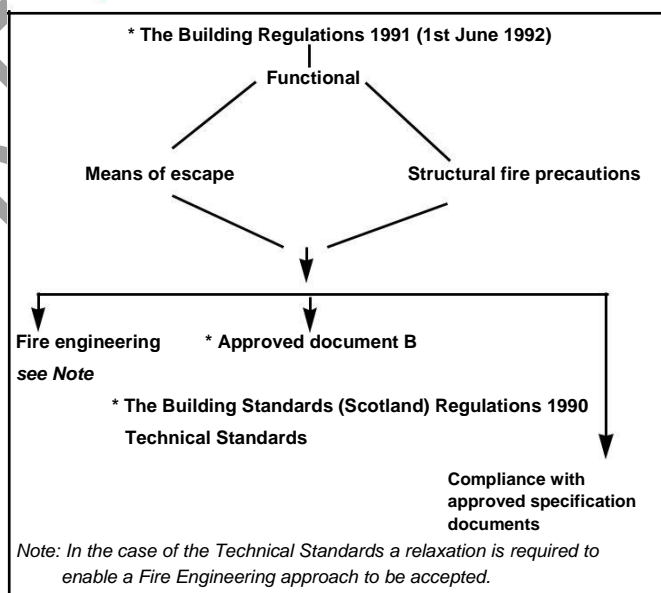

Fig. 2



7.0 The fire resistance test

- 7.1 The fire resistance test is defined in BS476: Part 20 et seq (formerly BS476: Part 8).
- 7.2 Tests are required to be carried out in UK NAMAS Approved Laboratories.
- 7.3 Test data from other laboratories including foreign laboratories can be utilised for assessment purposes.
- 7.4 The European harmonisation programme will include a fire resistance test, not dissimilar to the present British Standard Test and it is anticipated that there will be agreed techniques for data transposition.
- 7.5 The fire resistance test is carried out on an element of structure which in the case of an external wall would be of dimension 3 metre x 3 metre.
- 7.6 The test facilities in the UK are limited to this maximum size.
- 7.7 The test reflects a fully developed fire condition i.e. post "flashover" but the test does not set out to represent or simulate the real fire condition in any way.
- 7.8 The fire source in test is a gas fired furnace, controlled to follow a prescribed temperature rise with time condition as set out in Figure 3.

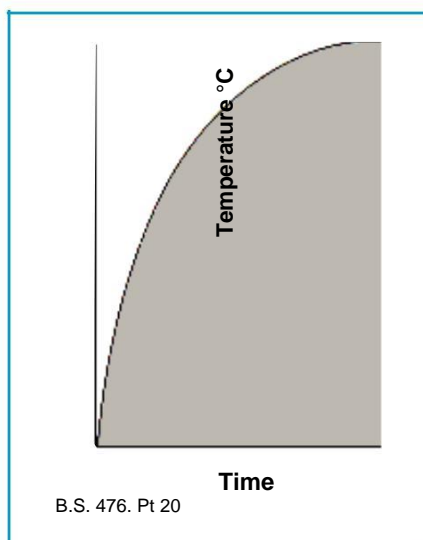

Fig. 3

- 7.9 The fuel input to the furnace is adjusted according to the requirements for maintaining the temperature regime and is very dependent on the combustible content and the thermal properties of the sample structure.
- 7.10 For example, a glazed wall construction would require a very high furnace energy input to overcome the high thermal loss whereas a timber wall construction would require a very low furnace energy input because of the heat liberated by the wall itself.
- 7.11 Whilst this may be considered as contrary to the real fire condition, the test is not intended as a simulation of fire but a means of according a performance in terms of well defined criteria, for regulatory purposes.
- 7.12 One side of the wall is exposed to the furnace with the furnace temperature being monitored 100mm from that face.
- 7.13 Measurements are made on the other side of the wall for judgement against the established criteria.
- 7.14 The wall for test is built into a specially designed frame which provides for structural restraint at all sides except that:
1. Where it is known that the wall in service will be greater in width dimension than 3 metres, then one vertical edge will be unrestrained and free to deform without restraint in the plane of, and normal to, the wall.
 2. In respect of 1 above the three edges which would be "restrained" should be installed in the frame as in practice with the requirement that the installation should be as realistic as possible using the fixing details employed in practice.
 3. Where lateral or longitudinal thermal expansion is likely to occur with heating which in practice would be resisted, no allowance for free expansion should be made in the installation of the specimen wall.



- 7.15 It is not unreasonable to accept the concept of increased width in service in which case the free end condition in 1 above would apply.
- 7.16 Further, it is not unreasonable to consider that in practice there will be partial or minimal head restraint against expansion in which case some provision for free vertical expansion may be permissible but is normally necessary to design a special detail to suit the test apparatus and achieve the concept without prejudicing the integrity. (The most severe test condition is possibly where full restraint is provided at all edges because of deformation and the influence on integrity, and in certain cases a separate test evaluation may be necessary).
- 7.17 Under the prescribed temperature/time condition of the fire resistance test judgement is made for the full test duration by applying the criteria of "integrity" and "insulation".
- 7.18 **Loss of integrity** is identified by the ignition of a cotton pad placed over a crack or fissure which is deemed to be constituting loss of integrity, with ignition within a maximum of 15 seconds; the furnace being maintained at a positive pressure of 8.5 Pascals per metre height above the notional 1 metre high neutral plane. For a 3 metre test specimen the pressure at the head would be 17 Pascals, up to a maximum permitted limit of 20 Pascals.
- 7.19 When the surface temperature on the unheated side, either general or local to joints etc. attains 300°C the cotton pad test is discontinued and loss of integrity is identified by gap or fissure size which must be more than 150mm and 6mm or 25mm diameter and be a direct fissure into the furnace through which a straight rod 6mm or 25mm diameter can be passed. The 6mm diameter rod has to be moved 150mm along the fissure to constitute failure.
- 7.20 The gap criteria for integrity does not require the furnace to be operated at a positive pressure.
- 7.21 **Compliance with insulation** requires that the mean temperature on the unheated side does not rise by more than 140°C above ambient and the maximum temperature at any point does not rise by more than 180°C above ambient.
- 7.22 These limits are applicable to all fire containing or compartmenting elements, both horizontal and vertical and relate to the ignition temperature for sustained contact of combustible material.
- 7.23 For compliance with the requirements of the Approved Document B and Technical Standards a test has to be carried out at a NAMAS Approved laboratory. An Assessment, however, can be carried out by a qualified body and utilise test data from other laboratories where appropriate, and can be offered in lieu of a test.
- 7.24 An Assessment does not embrace the fire engineering aspects associated with the integration of the wall into the building structure and the effects of dimension.
- 7.25 The recommendations set out in the Approved Document B and Technical Standards in respect of external wall construction specify periods of fire resistance which are determined by the use of the building and its size.
- 7.26 The fire resistance requirements can vary from ½ hour to 2 hours (England and Wales) and ½ hour to 4 hours (Scotland).
- 7.27 The area of the external wall requiring fire resistance is described as "protected" and any other area which would not have fire resistance including windows etc. is described as "unprotected".



8.0 Consideration of fire test criteria

7.28 The required "protected" area of an external wall will depend on the location of the wall relative to the boundary.

7.29 For walls which are **1 metre or more** from the relevant boundary and require to have fire resistance the "insulation" criteria are relaxed to 15 minutes irrespective of the requirement for "integrity" and the wall has to provide the fire protection from inside to outside only.

7.30 For walls which are sited **within 1 metre** of the relevant boundary and require to have fire resistance there is no relaxation of the "insulation" requirement and the wall has to provide the same fire resistance from inside to outside and separately from outside to inside.

8.1 "Stability" in a non-loadbearing context is not included within BS476: Part 20 et seq as compliance with "integrity" would infer that the wall was able to resist collapse under self-weight.

8.2 This publication places considerable emphasis on the need for the wall design to resist any measure of instability by deformation or development of stress as this is crucial to the effective performance of the wall in real fire.

8.3 Compliance with "integrity" by either the cotton pad test or rod test method is not necessarily an indication of the stability of the wall in the test size or in the 'oversize' arrangement.

8.4 However, this publication recognises the need for compliance with "integrity" as an indication of the effectiveness of the wall in terms of fire spread control but generally it is not likely that loss of "integrity" with fire from the inside of the building would lead to fire spread due to the absence of combustibles in contact with the outside surface of the wall, except at low level where there is always the possibility of stored materials, rubbish etc.

8.5 In the reverse situation of a fire on the outside of the building, there remains the hazard of fire spread to combustibles on the inside by loss of integrity.

8.6 This publication considers "integrity" to dominate over "insulation" as compliance with insulation is specific to the heating regime of the test and may not reflect the real fire scenario.

8.7 Experience has identified that fire spread through external walls is not generally as a result of heat transfer leading to spontaneous ignition of combustibles in surface contact

8.8 The relaxation of the insulation criteria to 15 minutes for walls 1m or more from the relevant boundary supports this view.

FOR REFERENCE



9.0 Review of basic design objectives

8.9 The emphasis, therefore, is on design aspects to ensure that the wall in the installed condition can realise, as far as possible, the objective of setting fire resistance standards.

8.10 This publication seeks to identify the important design principles acknowledging the need to comply with the Regulations which are functional.

9.1 In single storey construction the generally accepted design philosophy is that the roof need not have fire resistance and be stable in fire and can penetrate or collapse at any stage, provided any construction for fire resistance is not prejudiced by such collapse. However, the roof should be stable for a reasonable period to ensure adequate escape from the immediate area.

9.2 Where the external wall is required to provide fire protection then it must be stable after roof collapse and to achieve this the supporting columns or structure on which the wall depends must be able to withstand any overturning moment, or disruption generated by the roof collapse.

9.3 The more usual situation is a steel portal framed building where provided adequate base fixity is provided to the columns and they are adequately fire protected to the haunch, the rafters need not be protected and can be allowed to collapse together with the roof.

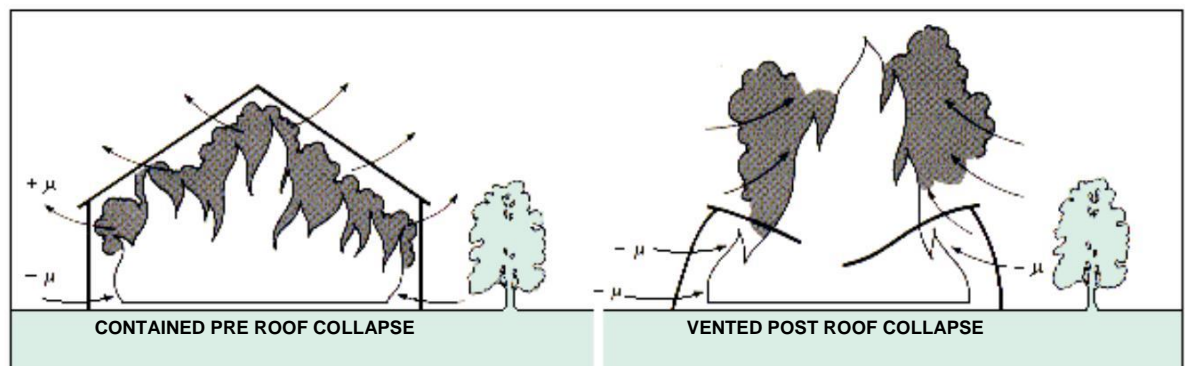

Fig. 4

9.4 Where there is inadequate base fixity to prevent overturning, the columns and the rafters are required to be protected to the same standard as the wall, and the roof membrane itself can be allowed to penetrate and collapse. (For a wall 1 metre or more from the boundary the level of fire protection to the steel frame would normally equate to the integrity requirements for the wall).



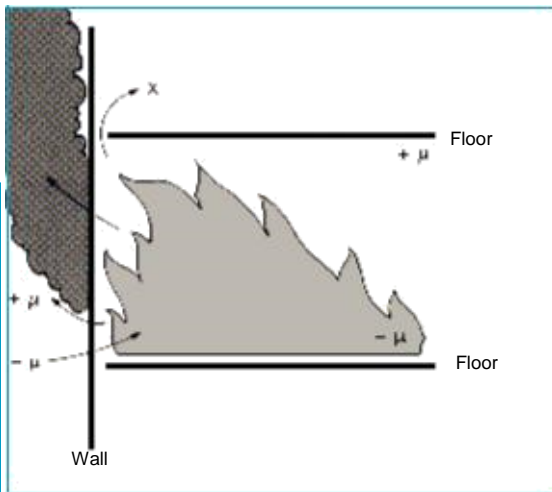

Fig. 5

9.5 Where any eaves beam is essential to the fire performance of the wall in terms of the wall stability or in terms of the column stability as related to the wall, fire protection is required to the same standard as the wall subject to the comment in section 9.4.

9.6 With roof collapse the fire pressures on the wall would normally change from being positive to either ambient or negative, as the fire plume will draw air in at all levels as depicted in Figure 4.

9.7 In multi-storey buildings at levels other than at roof the fire conditions would remain as a contained fire and continue to generate a positive pressure.

9.8 This is depicted in Figure 5.

9.9 A limited area of the wall is likely to be exposed to fire with the restraint and continuity being provided by the surrounding undamaged areas.

9.10 The restraint against thermal expansion may cause deformation in the structural members and the support rails in a similar manner to the single storey situation but there requires to be more emphasis on the detailing at fire resisting floor and internal wall junctions to ensure satisfactory fire containment.

9.11 In particular the possibility of fire spread by breaching of the joint or gap at the position marked X in Figure 5 has to be addressed.

9.12 This gap would normally be required to be filled with fire resistant construction to ensure the continuity of fire resistance or be formed as a fire-stop.

9.13 A fire-stop would normally be considered as a means of making good an imperfection of fit and comprise a suitable material, generally of limited combustibility, tightly wedged into position.

9.14 It is emphasised that there is no intention that a fire-stop would provide for the continuity of fire resistance.

9.15 Fire attack on the external side could occur from internal fire breaching windows or other "unprotected" areas or from an adjacent building or from debris and combustible materials stored against the wall on the outside.

9.16 In the above cases the fire pressures on the wall would generally not be as severe as the "internal" contained fire situation.

9.17 Under the fire conditions described the external wall for a fire protection application should:

1. Remain integral as a fire "baffle" to prevent fire spread between buildings.
2. Have sufficient inherent strength to resist collapse under anticipated stress levels due to self-weight, expansion and deformation of the supporting elements.
3. Maintain "integrity" within the meaning of the term defined in BS476.
4. Provide "insulation" within the meaning of the term defined in BS476.
5. Incorporate detail to prevent ingress of fire, including the combustion products, into the wall cavities at window and door openings etc. which constitute the "protected" and "unprotected" areas.
6. Provide for a means of preventing fire spread at fire resisting element junctions.



10.0 Fire engineering

10.1 The science of fire engineering is a means of obtaining compliance with the Regulations and the functional requirements without necessarily adopting any of the recommendations of the Approved Document B or requirements of Technical Standards. (It should be noted that in the case of the Technical Standards a relaxation is necessary).

10.2 The science may be applied in part or in full dependent on the circumstances and may employ "active" techniques as opposed to "passive". Examples of "active" techniques include sprinkler protection, smoke control by extract or pressurisation, aqueous solutions as a coolant etc. The "passive" systems rely very much on the standard fire test approach.

10.3 The introduction of a functional approach to Regulations has enhanced the status of fire engineering techniques.

10.4 In respect of external wall construction, fire engineering techniques which have a structural and thermal basis are relevant. These may be employed separately or combined to develop a fire protection solution within a project.

10.5 Structural considerations

1. The structure in question, i.e. column or beam, may not be fully exposed to fire attack in the manner of the fire resistance test and thus the fire protection thickness may be adjusted according to the P/A of the section.
2. The P/A is the ratio between the exposed perimeter of the steel section and the cross sectional area of the steel section, expressed in units of M^{-1} .
3. An application where this is important is typically a column section, part of which projects from the internal lining of the wall, where the internal lining is fire protective for the same fire resistance of the column. In such case the small portion of column exposed would require a reduced protection thickness because of the adjusted P/A.

4. The principles of P/A are published in Fire Protection For Structural Steel in Buildings, third edition 1992.
5. Fire protection manufacturers' published data on fire protection thicknesses for stated steel sections and fire resistance is generally based on an adopted temperature criterion in place of load carrying capacity as the data reflects the standard fire test.
6. The adopted temperature criterion of 550°C in place of load carrying capacity assumes an applied load which is the maximum permitted by design which is maintained constant during fire exposure, in either an axial compression or flexural mode in the case of a column and beam respectively, there being no procedures for a tension member.
7. Where in practice the load and resultant stress level can be identified as being less than the maximum permitted by design in fire, a higher temperature criterion can be adopted with a resultant reduction in protection thickness.
8. However, adopting a fire engineering approach can identify other criteria which can be dominant, for example, thermal expansion, and thus a structural analysis may be necessary to identify and quantify these factors.

10.6 Thermal consideration.

1. Whilst the data base for the structural fire design would normally be related to the BS476 fire resistance test philosophy, the concept of fire engineering allows for the consideration of real fire and the influence of factors such as fire load density, ventilation, and compartment and building geometry etc.



2. For a building of defined usage where the influencing aspects of fire are controlled such as a hospital, airport terminal etc. the severity of fire attack to the structure may be considered on a Time Equivalent basis.
3. The Time Equivalent is the period of time for which the fire resistance test of BS476 would have to be carried out on the structure in question, to achieve the same damaging effects as the anticipated real fire. Thus an example may be where according to the recommendations of the Approved Document B or requirements of the Technical Standards 2 hour fire resistance is required, a fire engineering study may identify that the 2 hours could be reduced to say 40 minutes without loss of safety standards.

10.7 Combined approach

1. The structural consideration of P/A and stress level may be combined with the Time Equivalent approach to develop the solution for a particular project.

10.8 In respect of external walls a fire engineering consideration would not normally change a constructional specification except in respect of the protection to the main structural supports, but can serve to identify the confidence level in extrapolating from the tested area of 3m x 3m.

10.9 Roof collapse to vent a fire is very significant in terms of the thermal and pressure effects on the external wall, which is a sound basis for a consideration of the fire damaging effects on the wall using fire engineering techniques.

10.10 The principal source of data for both a structural and thermal fire engineering consideration is the fire resistance test of BS476 provided the test has been instrumented in a manner that allows for a full temperature profile during test as opposed to a demonstration of compliance with the insulation criteria.

10.11 Thus in any fire resistance test carried out in accordance with BS476 the temperature of all important components should be measured as it is on this data that judgement can be made on thermal expansion, loss of strength, deformation, heat transfer etc.



11.0 Design considerations for an external wall

11.1 The following recommendations have been developed from fire test data and real fire experience and are applicable to both a Fire Resistance situation as specified in the Approved Document B and Technical Standards and a Fire Engineering and Time Equivalent approach as embraced by the Regulations.

11.2 Support columns

1. The structural columns may not require to have fire resistance as part of the structural frame of the building because of the circumstances of the building but may require fire resistance as the fire resisting external wall is wholly or partially supported by the columns.
2. This would apply whether the columns are pin jointed at the base and therefore reliant on the rafters for stability or have adequate base fixity in which case the rafters are redundant in fire.
3. There is a wide range of product systems which can be used to achieve the required fire resistance and a suitable reference document, which is not exhaustive is Fire Protection for Structural Steel in Building, third edition 1992.
4. The concept of P/A can be applied, also the revised critical temperature approach to develop a protection thickness for the different configurations of fire exposure.
5. The "internal" lining has to be integrated into the column protection in a manner that is not adverse to the protection and to the wall construction in fire performance terms.
6. Provided that an integration which can ensure integrity can be formed then the column need only be protected on that portion which is directly exposed to fire, this applying where the "internal" lining or the lining in association with the insulating infill can fully insulate that part of the steel section in the cavity which is not individually protected.

7. A diagrammatic presentation of a typical example is shown in Figure 6.

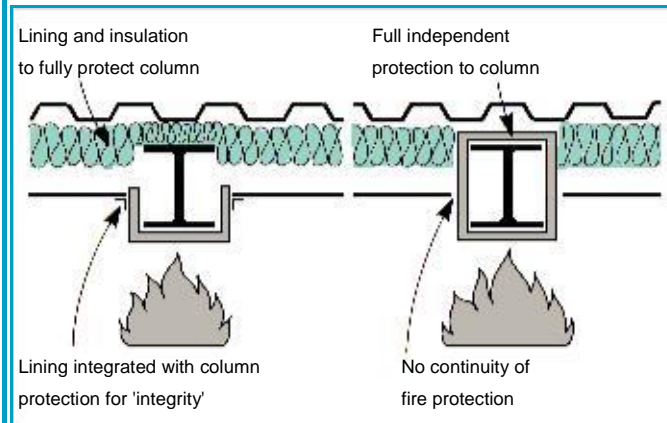

Fig. 6

8. In the situation of fire attack on either side (within 1m of the boundary) it may be necessary to introduce insulation between the steel section and external lining to control heat transfer by radiation. This is depicted in Figure 7 where the steel sections are not protected individually by a four sided protection system.

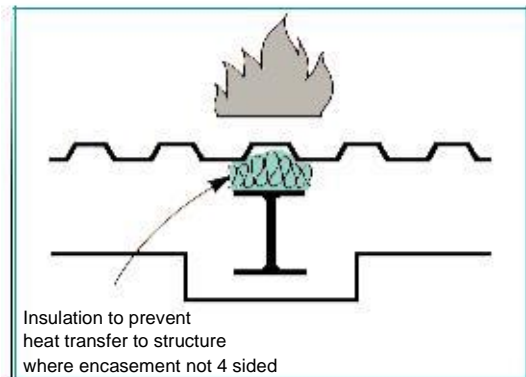

Fig. 7



11.3 Beams

1. Beams which are part of the structural frame and which occur at the perimeter line would be protected in the normal manner but with the requirement that the beam or floor construction is integrated into the wall, where fire resistance is required in the wall, as a fire stop detail or as continuity of fire resistance.
2. Eaves beams may be essential for main frame stability in fire in which case fire protection to the required standard is necessary.
3. Where the eaves beam is not essential for main frame stability in fire and serves only to support the external wall at eaves line a reduced fire protection standard may be applicable because of the reduced stresses or in certain cases the fire protection can be omitted.

11.4 Rails

1. At the rail position, particularly where the rails are not contained in the cavity and are therefore fully exposed to fire, there will be a measure of heat conduction to the main support columns via the fixing cleats etc.
2. It is not generally considered that the extent of heat transfer is significant in terms of stability of the columns in fire as there are factors of safety in developing the protection thickness to the column that more than offset this local heat transfer.
3. A dominant factor in this is the stress within the column section which is significantly reduced on roof collapse.
4. A further factor is the identification of P/A for the protection thickness which assumes that all exposed surfaces of the steel section would be heated as per the BS476 test regime which is not the case where shielding occurs.

5. In some fire resistance tests special measures have been taken to ensure that the rails have unrestrained freedom for expansion by the use of slotted holes and plastic washers.
6. Technically such principle should be employed in all cases as for the tested wall with expansion for increased length rails determined on a pro rata basis.
7. Extrapolation of this detail to increased length rails is not considered a satisfactory design strategy as under fire conditions rail deformation by thermal gradient effects is likely to negate the expansion provision as the rails will follow the least line of resistance.
8. This is particularly so for cold rolled sections where significant temperature profiles could occur leading to high deformation forces.
9. The concept of providing for designed expansion assumes that the columns remain in their datum position which is not the case as deflection and deformation is likely due to temperature increase and temperature profiles.
10. If such detail is introduced it is imperative that the bolts are positioned in the correct end of any slot to allow for maximum free movement.
11. This publication assumes rail centres not exceeding 2m.

11.5 Wind bracing

1. The philosophy of protection is reviewed in Fire Protection for Structural Steel in Buildings, third edition 1992, with the conclusion that:
 - (a) No protection is generally necessary
 - (b) Where protection is essential the protection thickness may be based on a P/A of 200M² irrespective of the section size.
2. Where the bracing member is contained in the wall cavity there would normally be no necessity for any further applied protection, except in respect of the arrangement in para 3.



3. The exception is where the wall is more than 1m from the relevant boundary, the structural frame is 1 hour or 2 hour fire resistance and the linings on the "internal" side are sacrificial after the notional 15 minutes for compliance with insulation.

11.6 External cladding

1. Extensive data is available on tested designs of external wall construction and on real fire experience, and this enables design recommendations, fire recommendations only, to be set down.
2. The following applies to formed steel sheet of corrugated, trapezoidal and tray sections and a range of profile sheeting, in thickness range 0.5mm to 0.9mm.
3. The objective is to form an impermeable barrier which is capable of withstanding deformation and distortion due to main frame movement and expansion within the sheeting and the rails, without rupture such that there is potential for fire spread or transfer.
4. The precise criteria of "integrity" is recognised but in large wall construction such precision may not be possible so the functional requirements of the Regulations are adopted and it is on this basis that the recommendations are given.

5. Fixings to rails

The following options apply:

- (a) 4mm steel hook bolts to the rails, at maximum 600mm centres.
- (b) Self drill self tapping bolts (steel) 5mm, at 300mm centres.

6. End laps

Lap to be not less than 100mm with fixing between sheets using steel screws 4mm at maximum 300mm centres (normally the screw fixings to the rails would be used wherever possible).

7. Side laps

Lap to be not less than one full corrugation on profile with fixings, at notional 360mm increments, between sheets using:

- (a) Steel pop rivets for ½ hour fire resistance applications.
- (b) Self drill self tapping screws (steel) 3mm for in excess of ½ hour fire resistance applications.

Steel pop rivets have been shown by test to be satisfactory for a 3m x 3m wall section but for an appraisal with no limit on dimension of the wall and fire resistance period the steel pop rivet option is not included.

11.7 Cavity insulation

1. A distinction is made between insulation for thermal requirements and insulation for fire protection.
2. The following recommendations are specific to fire protection and take no account of the levels of insulation required for environmental considerations.
3. For walls more than 1m from the boundary compliance with the insulation requirements is limited to 15 minutes.
4. This level of insulation may be achieved by the use of a suitable lining or insulating material which is fire stable and insulating for 15 minutes.
5. After 15 minutes the lining and/or the insulation can collapse or be exhausted as the steel sheet external lining will provide for integrity.



6. Where steel sheet internal linings are used with an insulating material infill special attention may have to be given to any heat conduction path which within the first 15 minutes of test would cause failure of the maximum temperature criterion for the "external" side.
7. The heat transfer path may be interrupted by insulating pads or strips or the design detailing may utilise "melt out" components which reduce the thermal bridge effect in fire.
8. For the large wall construction the emphasis should be on good structural design and continuity as opposed to attempting to theoretically comply with the 15 minutes insulation imposed via the Approved Document B and Technical Standards, as taken within the context of the building and real fire a deviation from the 15 minutes is justified if the confidence in the wall integrity and stability is enhanced by sound mechanical principles which are not dependent on specialist site skills.
9. Where insulating material is used which relies on mechanical support, then such mechanical support should not fail within the 15 minutes to cause collapse or slumping of the material.
10. Where compliance with the insulation criteria is required for the full fire resistance period, substantial insulation is necessary with specific detailing to prevent localised heat transfer paths.
11. The insulation has to be fire stable for the full period.
12. It is in these applications that full recourse to either insulating fillets or "melt out" components or a combination of both has to be considered.

11.8 Internal lining

1. The 'internal' linings may be formed in the following ways:
 - (a) Steel sheet (with cavity insulation as crushed rock wool, blast furnace slag wool, glass wool, ceramic wool etc. or as an insulating rigid sheet material).
 - (b) Other sheet material (with or without back-up of fire insulation).
 - (c) Wet applied materials of "passive" composition (normally applied to a support medium).
2. The linings may incorporate the rails in the cavity so formed or the rails may be fully exposed.
3. In terms of rail stability there is every advantage in incorporating the rail into the cavity, particularly where the "internal" lining has the capability of remaining in place for the full period.
4. The "internal" lining may be required to be positively fixed to the column or column encasement/protection or the lining may abut with the gap being sealed in a fire stop manner, the method employed being dependent on the precise detail of the wall design and the form of column protection.
5. The linings may be floor to ceiling height and fixed at floor and soffit (note that a full closure of the cavity may be required as a cavity barrier or as continuity of fire resistance) or be continuous between floors (note that the cavity so formed requires a cavity barrier and also the gap between lining and floor may require a fire stop or construction to preserve the fire resistance of the floor).

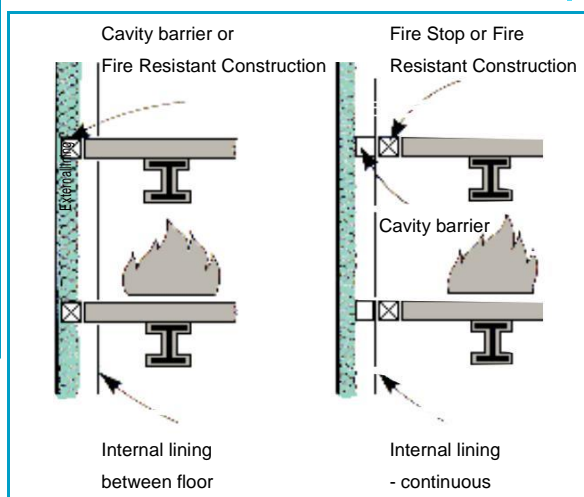

Fig. 8



6. The diagram Figure 8 depicts the two situations.
7. The following generic constructions for "internal" linings when used with the "external" linings referred to in 11.6 can be considered without the need for direct test information.

11.9 Internal lining - steel sheets

AWalls 1 metre or more from the relevant boundary.

1. Internal lining of profiled steel sheet, trays, etc. within the thickness range 0.4mm to 0.7mm.
2. Steel sheet or trays etc. to be arranged vertical or horizontal.
3. Horizontal fixings or fixings along shorter length to rails or equivalent (at 300mm maximum centres dependent on sheet profile) - 3mm steel self drill self tapping screws at notional 300mm maximum centres.
4. Horizontal lap or lap at shorter dimension, if appropriate - minimum 70mm.
5. Vertical lap or lap along longer dimension - minimum one corrugation on profile.
6. Fixings at laps - 3mm steel self drill self tapping screws or steel pop rivets at 300mm centres.
7. No special provision is normally necessary to allow for thermal expansion in fire.
8. Trim for "internal" lining to floor soffit and walls (if appropriate) - 40mm x 40mm x 20swg steel angle section.
9. Trim secured to structure with 4mm "all steel" fixing bolts/screws at 4.50m maximum centres.

10. Fixing of "internal" lining to trim - 3mm steel self drill self tapping screws or steel pop rivets at 400mm maximum centres.
11. Typical cavity insulation in quilt or slab material of not less than the following specification can be considered:
 - a) Quilt - glass wool - 60-80mm at 10-12kg/m³
 - b) Quilt - crushed rock, blast furnace slag, wool 60-80mm at 20kg/m³
 - c) Quilt - ceramic wool - 50mm at 45kg/m³
 - d) Slab - glass wool - 100mm at 60kg/m³
 - e) Slab - crushed rock, blast furnace slag, wool - 60-80mm at 60kg/m³

A - Walls 1m or more from relevant boundary

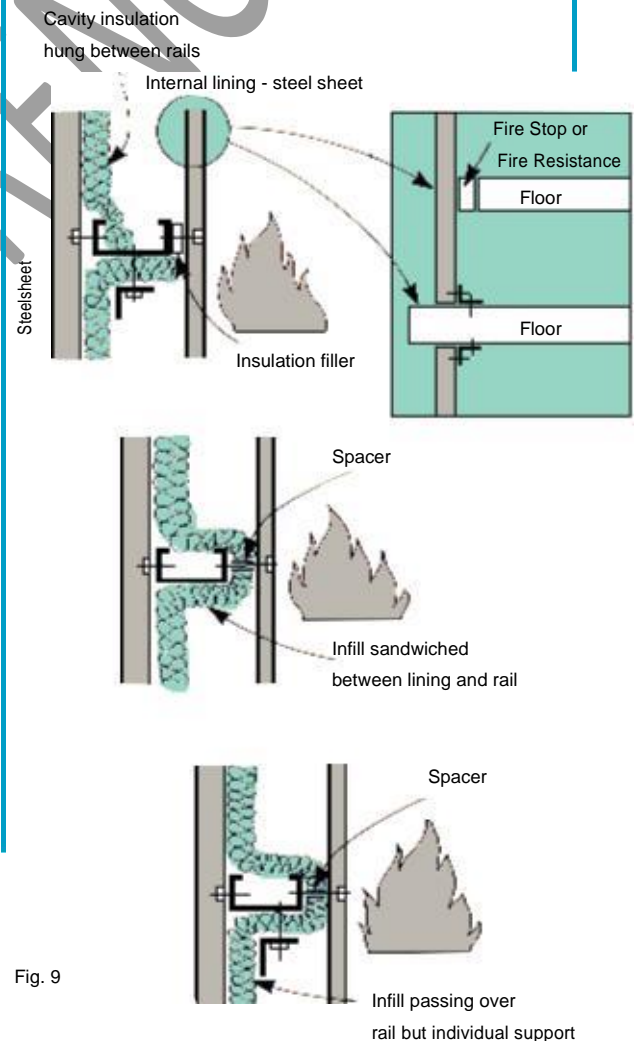

Fig. 9



12. The specification for the cavity insulation would be either Class 0 or limited combustibility as appropriate.

13. Fixings for cavity insulation refer Fig. 9 - reference a), b), c), the quilt where reinforced with steel laced chicken wire mesh may be hung with tightly butting and laced vertical joints, with suspension by clamping at each rail position by the use of separate steel components 30mm x 30mm x minimum 20 swg angle section or 25mm x 1.5mm x flat section, in maximum length 2 metre, steel screwed to the main rails with 3mm self drill self tapping screws at 400mm centres.

Alternative fixing is by sandwiching the quilt between the linings and the rails (with suitable spacers where necessary to achieve adequate compression).

14. In respect of d) and e) the slabs are wedged in position by cutting oversize and with compression at all joints, with horizontal joints staggered.

15. Note: At all thermal bridge positions created by the rails if included in the cavity or by spacer and support components where the rails are fully exposed on the "internal" side, an insulating fillet is necessary to control heat transfer within the 15 minute period so that compliance with the insulation criteria can be achieved.

16. The insulating fillet may comprise a board material, non combustible or of limited combustibility, of density not less than notionally 200 kg/m³ and thickness not less than 6mm.

17. Proprietary techniques to achieve thermal disassociation in fire are available.

B Walls within 1 metre of relevant boundary

1. Paragraphs 1-10 inc. as set out above apply.

2. As the insulation criteria apply when either side is exposed to fire special consideration in respect of insulation and localised heat transfer is necessary.

3. Recommendations for thermal insulation are as follows:

Half hour fire resistance.

- a) Insulation - crushed rock, blast furnace slag, wool, steel wire laced chicken wire mesh reinforced - 30mm at 80-100kg/m³.
- b) Thermal disassociation - the insulating fillet may comprise a board material, non-combustible or of limited combustibility, of density not less than notionally 200kg/m³ and thickness 6mm. (See para 16).

One hour

- a) Insulation - crushed rock, blast furnace slag, wool in slab form - 50mm at 80-100kg/m³ density.
- b) Thermal disassociation - the insulating fillet may comprise a board material, non-combustible or of limited combustibility, of density not less than notionally 200kg/m³ and thickness 6mm (see para 16 above).

Two hour

- a) Insulation - crushed rock, blast furnace slag, wool in slab form - 80mm at 100/kgm³ density.
- b) Thermal disassociation - the insulating fillet may comprise a board material, non combustible or of limited combustibility, of density not less than notionally 200kg/m³ and thickness 10mm.

11.10 Internal lining - other sheet materials

A Walls 1 metres or more from the relevant boundary

1. There is a range of sheet materials available which can be used to form an internal lining for fire protection and for aesthetic purposes but they are all within the definition of "proprietary" and thus no generic solution can be given.



2. However, the internal lining may be considered as sacrificial in fire where the insulation in the cavity provides for the 15 minutes compliance with the insulation criteria provided the fixings for the sacrificial lining continue to support the insulation after collapse or destruction of the lining or a secondary fix system is used. Refer Fig. 10.

A - Walls 1m or more from relevant boundary

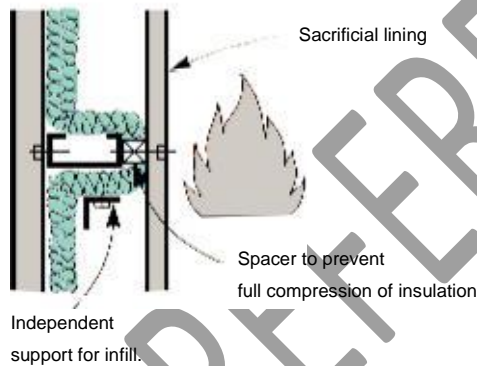
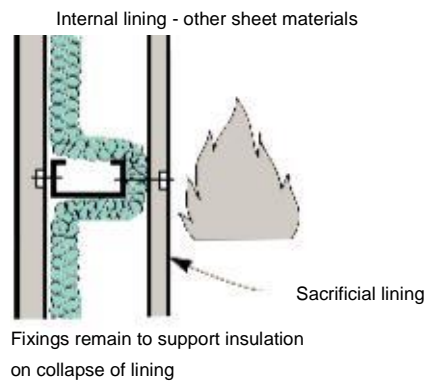

Fig. 10

3. In this case the insulation is to be formed from crushed rock, blast furnace slag wool in quilt form, steel wire laced chicken wire mesh reinforced and installed as a homogeneous membrane on the "internal" side with all joints tightly butted and steel wire laced to embrace the rail or structural supports for the "external" lining thereby eliminating any heat transfer path.

4. The support for the quilt to be provided by clamping to the rails etc. with 30mm x 30mm x 18swg steel angle section or 30mm x 2mm steel flat section fixed with 3mm steel self drill self tapping screws at 350mm centres; the clamp sections being in maximum length 2 metre.
5. Spacers, as necessary, are to be provided at the rails to prevent excessive compression of the insulation.

B) Walls within 1 metre of the relevant boundary

1. In this situation it would normally be necessary to form the "internal" lining from materials which are fire stable and insulating for the full fire resistance period as it is not practical to rely on the insulation infill to provide for the full compliance particularly where conductive paths occur.
2. The forms of construction would be wholly proprietary in their design and no generic recommendations can be given.

11.11 Internal linings - wet applied materials, passive composition.

A) Walls 1 metre or more from relevant boundary

1. There is a range of wet applied proprietary materials which includes trowelled and sprayed particulates (for example Vermiculite and Perlite) and sprayed wool (for example crushed rock/blast furnace slag wool) which generically can be described as "passive" as opposed to coatings such as intumescent which are generically "active" i.e. they change their form on the action of fire.



2. The wet finishes described would normally be applied to a support steel mesh or lath system tied back to a support framework, with the joints between sheets of mesh or lath being lapped and securely laced.
3. The finishing material when applied to the mesh passes through the holes in the mesh to form a mechanical key which is vital for satisfactory fire performance.
4. Where such mechanical key cannot form because of the absence of the void behind the mesh or lath, for example where the mesh or lath is fixed tight back to a flat substrate, the applied material should not be considered as fire protection unless specific fire test evidence is available.
5. This detail is depicted in Fig. 11.

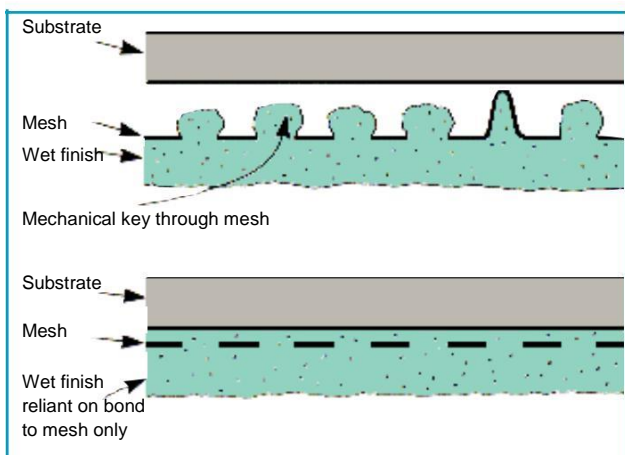

Fig. 11

6. These finishing materials may be contoured around the support columns to form a homogeneous "internal" lining system.
7. Linings so formed have the capability of maintaining their integrity and providing insulation for the maximum period of fire resistance, dependent on the thickness applied, which for specification purposes is always referred to as being measured from the face of the support mesh or lath.

8. No special measures are necessary to cater for walls of large dimension, except to allow for movement joints in the finish, as necessary.
9. Insulation may be included in the wall cavity to complement the "internal" lining in fire terms and may include glass, crushed rock/blast furnace slag wool and ceramic wool.
10. To identify the thickness of spray or trowelled material required reference to proprietary data is necessary.

B Walls within 1 metre of the relevant boundary

1. Statements in 1-10 inc. apply.
2. The thickness of material applied to the mesh or lath can be increased to achieve full compliance with the insulation criteria for the consideration of fire attack from either side.
3. Where the thickness is excessive for the higher periods of fire resistance it may be necessary to introduce a light gauge steel reinforcing mesh (50mm chicken wire mesh) tied back to the support mesh or lath with steel wire and pulled away from the support mesh or lath during the finishing material application so that on completion the reinforcing mesh is at notional mid thickness.
4. The important factors with all "passive" spray or trowelled finishes are:

- 1 Attainment of the required thickness
- 2 Attainment of the correct notional density
- 3 Provision for adequate mesh/lath support
- 4 Positioning of "in depth" reinforcement, if required.

5. Adequate site control should be exercised to ensure that the proprietary design specification is complied with.



11.12 Closure at openings

1. Where openings are formed in the wall irrespective of the wall having fire resistance, such as at doors, windows, services etc. access into any void in the wall construction must be closed to ensure that fire is not able to exploit the cavity.
2. The exception to this is where the cavity is filled completely so that in theory no void is created.
3. The closure detail in non-fire resisting situations may comprise a material or a system which either can be "deemed to provide" a cavity barrier or is of a proven cavity barrier design.
4. At such openings the fitting of a door frame or service transit etc. may form the required effective closure.
5. Any such component should be sealed to the external wall linings using a fire stop approach to preserve the fire protection continuity of the detail.
6. The use of a closure component in not less than 1.5mm thick steel sheet formed as a channel section or similar, to bridge between the "external" skin and the "internal" lining would provide for a satisfactory closure for fire protection purposes.
7. Fixings to the linings should be not less than 3mm in steel as self drill self tapping screws or equivalent at 400mm maximum centres.
8. Where the wall is required to provide fire resistance either for within 1 metre or more than 1 metre of the relevant boundary the closure detailing is required to be designed for a fire performance comparable to the integrity of the wall except where the "internal" lining is sacrificial in which case the closure would only be effective for the fire life of the "internal" lining.

9. Where the lining is sacrificial as identified above consideration may need to be given to the closure of other cavities in the construction, for example between the insulation and the "external" lining in which case the detailing is still required to provide closure of the cavity so formed.
10. The steel sheet closure component described is satisfactory for fire resistance applications.
11. However, the use of a steel bridging component at the opening position will allow heat conduction and a theoretical failure of the insulation criteria, should it be applicable, but such localised high temperature is not deemed to constitute a fire control problem and because of it being adjacent to the opening, it may therefore be discounted.
12. The most common occurrence is at door and window openings in walls more than 1 metre from the relevant boundary where the doors and windows are considered as unprotected area i.e. no fire resistance is required.
13. The absence of a thermal break at the closure positions therefore is not of significant within the 15 minutes specified for insulation compliance.
14. Typical closure detail is shown diagrammatically in Fig. 12.

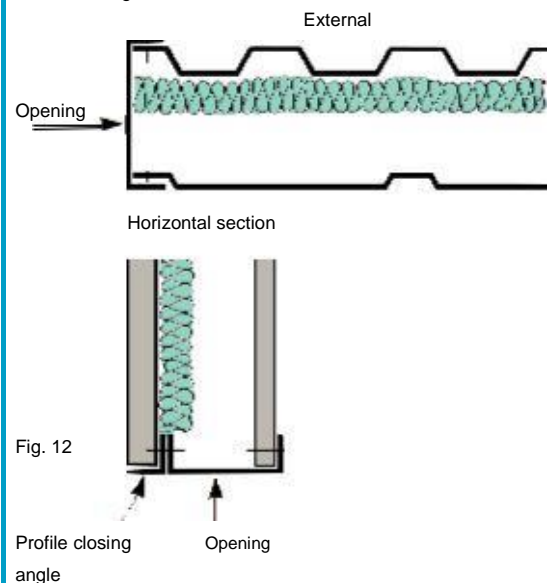

11.13 Cavity barriers and closure to structures

1. Cavity barriers are required to prevent the progress of fire, including the products of combustion, through the cavity in a concealed manner.
2. Thus where any cavity is created within the wall construction cavity barriers are required to be introduced at positions identified by the Approved Document B and the Technical Standards.
3. The frequency of the cavity barriers is influenced by the classification of the surfaces within the cavity (for maximum spacing the surfaces are required to be Class 0 or Class 1 in England and Wales - Approved Document B and Class 0 in Scotland - Technical Standards).
4. The requirement of a cavity barrier is that it should be of construction which can maintain its integrity for 30 minutes and provide for fire insulation for 15 minutes as determined by test in accordance with British Standard 476 Part 20 et seq.
5. There are no approved and specified constructional recommendations for an external wall cavity barrier for the building application intended by this publication where the size of the barrier would be less than 1 metre x 1 metre in cross section in the Approved Document B but the Technical Standards specify that for such situations the following materials/systems may be used.
 1. Non asbestos building board
 2. Plasterboard at least 12.5mm thick
 3. Steel at least 3mm thick
 4. Timber not less than 38mm thick
 5. Wire reinforced mineral wool blanket of minimum thickness 50mm
 6. Mineral wool slab
 7. Polyethylene sleeved mineral wool
 8. Cement, plaster etc. not less than 25mm thick

6. Items No. 5 and 6 would more generally provide an effective solution within the context of external walls identified in the publication.
7. It should be noted that in this context glass wool which is technically a mineral wool is included.
8. Cavity barriers should be mechanically fixed, clamped or sandwiched in such a way that they cannot be displaced under normal service conditions or in fire.
9. A clear distinction has to be made between a cavity barrier and a continuity of fire resistance.
10. Where, for example, a fire resisting compartment floor or internal wall of greater than half hour fire resistance abuts the external wall the form of construction used in the cavity may require to be of the same fire resistance as the floor or wall to preserve the compartmentation concept.

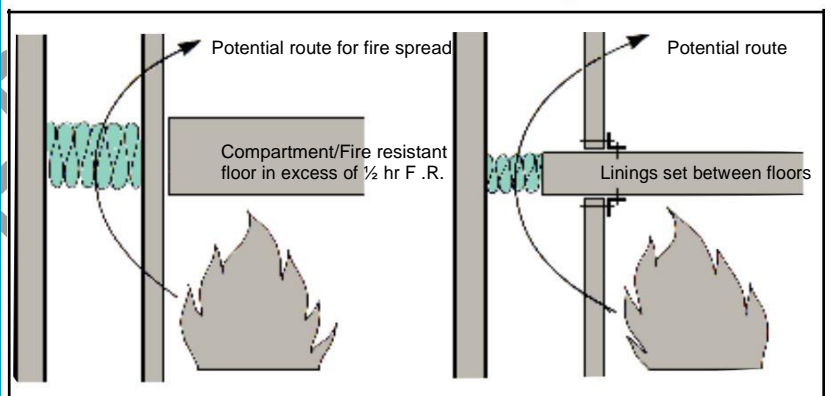

Fig. 13

11. Where the external wall, because of the requirements of fire resistance, has an "internal" lining which is comparable in integrity to the abutting wall or floor, the cavity closure may be considered in association with the "internal" lining except that the requirements for a cavity barrier will remain.



12. Typical situations are depicted in Fig. 13 and 14.

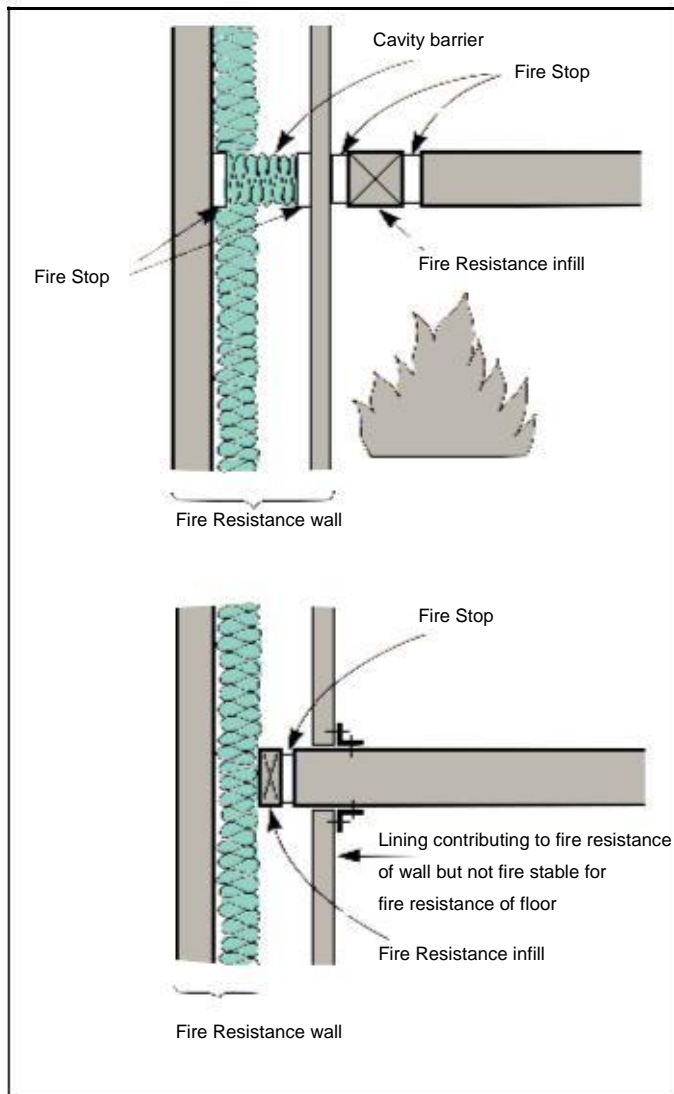

Fig. 14

13. Any infill provided for the continuity of fire resistance through the cavity must be supported by the fire resisting construction in such a way that it will not be displaced by any part of the "external" wall which may be destroyed under fire conditions.
14. To make good an imperfection of fit between the components and construction for cavity barrier or fire resistance application, a fire stop material may be used, but a fire stop material must not be considered as providing support for fire resistance purposes to the constructions in which it is used.
15. Typical materials which are considered as satisfactory for a fire stop application include glass wool, crushed rock/blast furnace slag wool, ceramic wool (with or without binders) and intumescent mastics.



12.0 Corner detailing

12.1 The testing of corner detailing for fire resistance applications is not within the scope of BS476: Part 20 et seq. No test facility exists which can be used to prove design solutions in a representative manner.

12.2 Typical situations are depicted in the diagram Fig. 15.

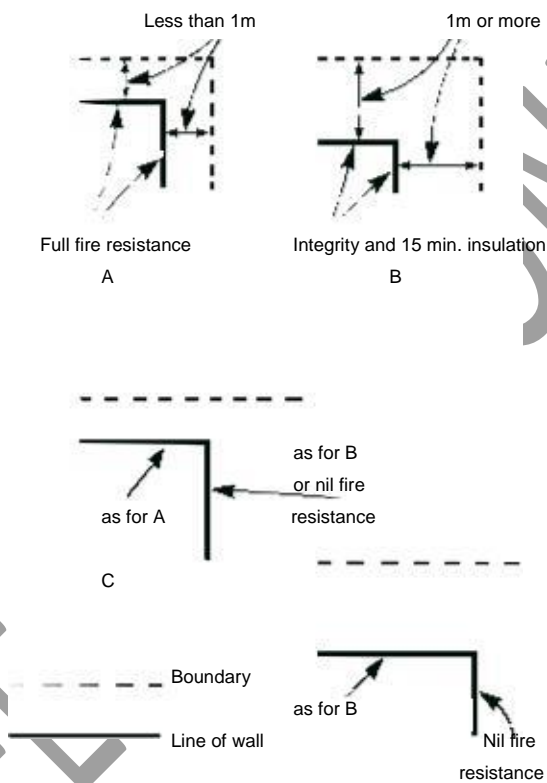

Fig. 15

12.3 Critical design concepts are:

1. That the continuity of the integrity of the "external" lining is maintained where the abutting walls are both performing a fire control function and similar continuity is provided in the "internal" lining dependent on the role of the lining in fire.
2. That the effectiveness of the "external" wall providing a fire control function is not adversely affected in terms of integrity or fire spread in the cavity, by partial or total collapse of the abutting non-fire resisting wall or parts of it.

12.4 Design recommendations

1. Concept 1
 - (a) The "external" skins at the corner detail require to be securely and positively mechanically linked together either by an overlapping design or by the use of a separate steel link component not less than 0.4mm thick.
 - (b) The securing of the skins together or to the link component should use not less than 3mm steel self drill self tapping screws/bolts at maximum 300mm centres.
 - (c) In the case of steel sheet internal linings similar mechanical linking is required with link plate dimension and fixings as for the external lining.
 - (d) The rails require to be mechanically linked by cleats and rigid bolting, the cleats being in rolled steel angle or channel in thickness not less than that of the rails if cold rolled section. The objective is to provide for structural continuity in fire.
2. Concept 2
 - (a) The cavity on the line of the theoretical separation between fire protection and non fire protecting areas requires to be closed by an appropriate barrier construction that is fixed in such a way that with distortion it is not displaced, thus applying the criteria for cavity barrier construction as set out in the Approved Document B and Technical Standards. Whilst the "external" lining in both areas is probably formed and fixed in a similar manner the structural supports for the area which is not fire protecting may not have protection applied in which case those areas of the wall may be unstable relative to the fire protected area.



13.0 Survey of important constructional detail

- (b) A plane of weakness at the junction of the two areas is essential to prevent any disruption or failure being progressive.
- (c) Where a structural link between the rails is provided for normal service conditions and it can be identified that the link is not required for overall fire stability, then it should be formed in such a manner that at high temperature disassociation can occur.
- (d) The use of aluminium components has been implemented as structural failure of a bolt or link component will occur at a temperature of notionally 600°C which would be well into fire development, reflecting the potential of a major fire.
- (e) Where any detail incorporates a "fusing" or "melting out" concept, special care is required to ensure that the use is limited to the detail where movement or disassociation in fire is required
- (f) It is recommended that in all cases a careful structural consideration should be given to the building as an entity even though only limited areas of external wall may be providing a fire control function, to ensure that those areas not accorded a fire control function are actually sacrificial in fire and they can therefore distort without control and/or collapse.
- (g) It is only after a careful analysis that the concept of fire disassociation should be implemented.
- 13.1 The following sets out a brief list of the detail for which special attention on site is necessary to ensure that a maximum standard of fire protection can be achieved.
- 13.2 These are factors which have significant importance for the external wall, in large area, to perform in fire protection terms as intended by the Regulations.
1. Fixings for the external lining to the rails.
 2. Vertical and horizontal laps between external sheets.
 3. Fixings at all lap positions.
 4. Protection to main structural supports either individually or as integrated with the cavity insulation and/or linings.
 5. Support for fire insulation in the cavity.
 6. Design, fixing and integration of internal lining.
 7. Preservation of fire integrity at all fire resisting wall/floor junctions with the external wall.
 8. Closure of all cavities at openings and at strategic positions to prevent fire ingress into and exploitation of the cavity.



14.0 Detailed recommendations for fire testing

14.1 When a fire resistance test as defined in BS476: Part 20 et seq is carried out it is a demonstration that a section 3m x 3m nominal can satisfy the set criteria of the test.

14.2 The recommendations of the test are that the section to be tested is "representative" of the wall in practice but this cannot be achieved as the effects of large dimension cannot be simulated reliably.

14.3 In all cases the results of the test have to be interpreted for the large wall construction bearing in mind that the Regulations, being functional, require a consideration of the wall in service and its ability to provide a fire control function. (Note should be made that the result of a test is applicable to the edge condition used i.e. full or partial restraint or free edge detail).

14.4 The situation of the wall within 1 metre and more than 1 metre from the relevant boundary represents two distinct test situations as a judgement of compliance with the insulation criteria on the basis of the one test is very difficult.

14.5 Also within 1 metre of the boundary the situation requires an evaluation from either side.

14.6 A typical test arrangement is shown in Fig. 16 and would utilise the 3 metre x 3 metre nominal test apparatus with the specimen restrained and fixed at one vertical side with the other side not restrained or fixed, as specified in the test standard for walls which, in service, are intended to be of greater width than 3 metre.

14.7 The diagrammatic representation shown in Fig. 16 has aspects annotated a, b, c, etc. which are referenced in the following text.

14.8 Support for the wall would be by two column sections (a), suggested size 203mm x 203mm x 52kg/m, base fixed (b) but with provision for free thermal expansion at the head by slotted hole and fusible washer detail at the fixing cleat position (c).

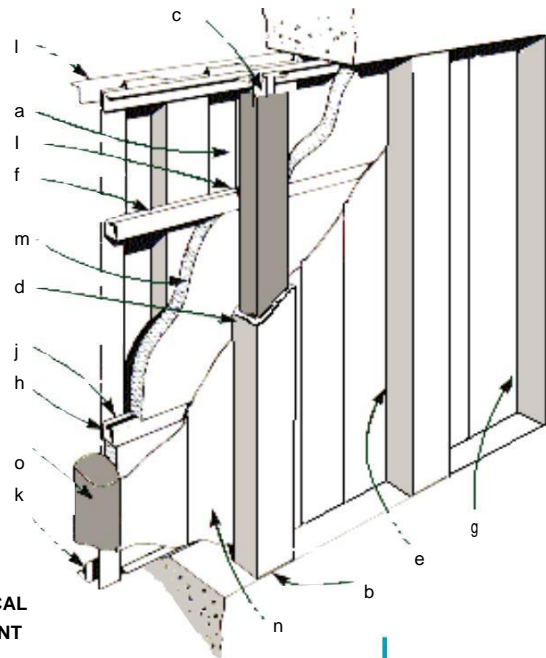

Fig. 16

DIAGRAM OF TYPICAL TEST ARRANGEMENT

14.9 The columns would be clad with fire protection either as four sided or less dependent on the overall wall design, but with thickness based on the theoretical P/A (d).

14.10 The fire protection would be full height between the faces of the concrete frame, and be fixed thereto, but with interruption of the protection at the rail fixing, if appropriate (e).

14.11 Two rails (f) would be incorporated, each being fixed by cleats at the restrained end (g) and cut short to allow a clearance at the unrestrained end (h).

14.12 It is not recommended that the rail to column junction (i) would allow for free movement in fire unless in practice such expansion provision pro rata for a full length rail can be implemented with confidence that the design concept will perform in a manner indicated by the test.

14.13 The external lining would be fixed at the rails in a representative manner (j) and vertical and horizontal laps would be included as in service.

14.14 At the base the sheeting would be secured in position (k) by the use of a steel angle section secured to the frame and fixed to the sheeting with steel self drill self tapping screws. Any gaps caused by the profiling of the sheet would be fully sealed for the purposes of the fire test as this detail would not reflect on-site work.

14.15 At the head a similar detailing would be employed (l) except that where the case can be made that the sheeting in service is not head restrained by an element of construction which has fire resistance, the sheeting in test can be allowed to expand freely by cutting short and clamping between angle sections or similar and fully sealing all gaps due to sheeting profile. The effective sealing at the top is of paramount importance.



15.0 Assessment and Appraisal

14.16 The cavity insulation (m) and the internal lining(n) would be introduced to represent the wall construction with the proviso that the internal lining where appropriate need not be restrained at the head, using a detailing similar to the external lining.

14.17 The sealing of the gap between the "free" end and the concrete test frame would be the responsibility of the testing laboratory (o).

14.18 To appraise the construction for walls greater than 3 metre x 3 metre a temperature profile during test is essential for all of the components of the construction.

14.19 For example, for a wall designed for within 1 metre of the relevant boundary, temperatures during test would be recorded for the following components.

1. Cavity side of lining exposed to fire.
2. Unheated side of cavity insulation
3. Rails
4. Support columns
5. Air cavities if any
6. Framing and support members other than the rails which are part of the design.
7. Thermal bridging designed to disassociate in fire.

14.20 The temperatures would be used to appraise the extent, if any, for designed thermal expansion, the effects of stress on the components by self-weight and restraint, deformation, buckling and relative movement between the components.

15.1 An **Assessment** is in lieu of a test to the relevant part of BS476 and is an expression of opinion as to the result which could be expected if a test was to be carried out.

15.2 Therefore, an Assessment is limited to that which can be tested which in the case of fire resistance, would be a wall notionally 3 metre x 3 metre.

15.3 An Assessment is expressed in terms of the identified criteria of the test, which for fire resistance is integrity and insulation.

15.4 An Assessment is permitted by the Approved Document B and Technical Standards.

15.5 An Appraisal is used to differentiate between a straightforward Assessment against the test and criteria and the consideration of the element in the size anticipated by the building.

15.6 An **Appraisal** is linked to the functional regulations and considers the wall in the context of the building.

15.7 An Appraisal may include other criteria if considered appropriate and may use a wide variety of fire engineering concepts for the solution of a particular fire problem.

15.8 The essential difference is that the full size element is considered as opposed to a test specimen and often this draws important structural aspects into focus with reduced emphasis on precise test criteria.



16.0 Definitions

The following definitions have been reproduced from the Approved Document B but are equally applicable to the Technical Standards.

Boundary. The boundary of the land belonging to the building, or where the land abuts a road, railway, canal or river, the centreline of that road, railway, canal or river.

Cavity barrier. A construction provided to close a concealed space against penetration of smoke or flame or provided to restrict the movement of smoke or flame within such a space.

Compartment (Fire). A building or part of a building, comprising one or more rooms, space or storeys, constructed to prevent the spread of fire to or from another part of the same building, or an adjoining building. (A roof space above the top storey of a compartment is included in that compartment).

Compartment wall or floor. A fire resisting wall/floor used in the separation of one fire compartment from another.

Element of structure.

- (a) A member forming part of the structural frame of a building or any other beam or column
- (b) A loadbearing wall or loadbearing part of a wall
- (c) A floor
- (d) A gallery
- (e) An external wall
- (f) A compartment wall (including a wall common to two or more buildings).

External wall (or side of a building). Includes a part of a roof pitched at an angle of more than 70° to the horizontal, if that part of the roof adjoins a space within the building to which persons have access (but not access only for repair or maintenance).

Fire-resisting (fire resistance). The ability of a component or construction of a building to satisfy for a stated period of time, some or all of the appropriate criteria specified in the relevant part of BS476.

Fire stop. A seal provided to close an imperfection of fit or design tolerance between elements or components to restrict the passage of fire and smoke.

Material of limited combustibility. A material performance specification that includes non-combustible materials.

Non-combustible material. The highest level of reaction to fire performance

Relevant boundary. The boundary which the side of the building faces (and/or coincides with) and which is parallel, or at an angle of not more than 80°, to the side of the building.



17.0 References

The Building Regulations 1991

The Building Standards (Scotland) Regulations 1990

BS476 : Fire tests in building materials and structures

Part 6: 1981 Method of test for fire propagation for products

Part 6: 1989 Method of test for fire propagation for products

Part 7: 1971 Surface spread of flame test for materials

Part 7: 1987 Method for classification of the surface spread of flame of products

Part 4: 1970 (1984) Non-combustibility test for materials.

Part 11: 1982 Method for assessing the heat emission from building products

Part 20: 1987 Method of determination of the fire resistance of elements of construction (general principles)

Part 21: 1987 Methods for determination of the fire resistance of loadbearing elements of construction

Part 22: 1987 Methods for determination of the fire resistance of non-loadbearing elements of construction.

Part 23: 1987 Methods for determination of the contribution of components to the fire resistance of a structure.

Part 24: 1987 Method for determination of the fire resistance of ventilation ducts.

18.0 Technical data sheets

18.1 Introduction

1. Fire tests have been carried out on forms of construction marketed by the members of the Association and this technical publication sets out relevant authoritative data.
2. It is intended as a validated guide for architects, specifiers, regulatory authorities etc.
3. The information is advisory and where it is necessary to obtain further details on the systems or materials or where copies of the validating documents are required, the company in question should be approached direct.
4. The technical data is correct as at the date of publication, but as testing and development is progressive with all systems and materials, a check should be made with the company concerned to identify if any revision applies.

18.2 Notes for use with the proprietary data

1. In this publication, where reference is made to Fire Resistance this means fire resistance as defined in BS476 Part 8 and Part 20 et seq.
2. In respect of "company name" this may be the manufacturer or supplier and it could also be the erection contractor.
3. Two categories of performance are identified in the data sheets, namely:

(A) For walls more than 1 metre from the relevant boundary,

and

(B) For walls within 1 metre of the relevant boundary.
4. The letter A or B is followed by a number representing the Fire Resistance in hours which can be provided by that construction.



5. It is stressed that in the case of category A the insulation criteria of BS476 are relaxed to 15 minutes and consideration is with fire attack on the internal side only, this being set out in the Approved Document B and the Technical Standards, whereas in the case of category B there is no relaxation of the insulation criteria and the fire performance has to be achieved with fire from inside to outside and separately from outside to inside.

6. Thus, for example, classification A2 means a wall more than 1m from the relevant boundary providing 15 minutes compliance with the insulation criteria and 2 hour compliance with integrity.

7. Similarly B½ means a wall within 1m of the relevant boundary providing ½ hour integrity and insulation from either direction.

8. The term "relevant boundary" is reproduced from the Approved Document B as follows:

"The boundary which the side of the building faces (and/or coincides with) and which is parallel, or at an angle of not more than 80° to the side of the building. A notional boundary can be a relevant boundary."

9. The terms "inside rail" and "outside rail" are explained by the sketches Fig. 19.

10. Unless otherwise stated the term "mineral wool" means a wool formed from crushed rock or blast furnace slag and excludes wool formed from glass.

11. Unless otherwise stated the systems are suitable for affixing to hot or cold rolled rails.

12. The rail centres can vary up to 2m maximum and for rail centres exceeding 2m reference should be made to the manufacturer of the external wall system.

13. The thickness of the internal and external sheeting is given for guidance only. The thickness of the surface coating is not consistently included in the figure given and where more precise data is required reference should be made to the manufacturer.

14. The thickness and density of insulation specified in the data sheets is the minimum for the stated fire performance. Other considerations, for example "U" value may require an insulation in excess of that which is stated.

15. The designs identified in the data sheets incorporate special proprietary constructional techniques which have enabled the required fire performance to be achieved. These special techniques have to be correctly implemented by instruction from the manufacturer, before any fire performance can be claimed.

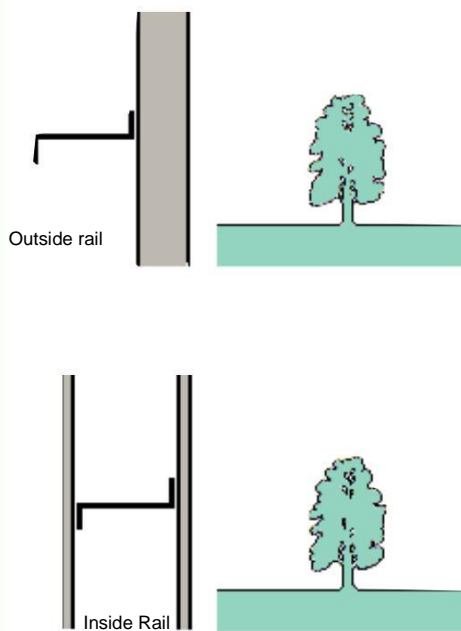

Fig. 19



For details of products available to meet specific applications further information is available from the MCRMA members listed below:

Adam G. Brown & Company
British Steel Profiles
CA Profiles Limited
Euroclad Limited
European Profiles
Hoogovens Aluminium Building Systems Limited
Precision Metal Forming
Quedron Distribution Limited
SpeedDeck Building Systems Limited
TAC Metal Forming Limited
Uniclad Systems Limited
Ward Building Components Limited

Other MCRMA publications:-

- No. 1 Daylighting recommended good practice in metal clad light industrial buildings
- No. 2 Curved sheeting material
- No. 3 Secret fix roofing design guide
- No. 4 Fire and external steel clad walls guidance notes to the revised Building Regulations, 1992
- No. 5 Metal wall cladding detailing guide
- No. 6 Profiled metal roof design guide

Liability

Whilst the information contained in this design guide is believed to be correct at the time of going to press, the Metal Cladding and Roofing Manufacturers Association Limited and its member companies cannot be held responsible for any errors or inaccuracies and, in particular, the specification for any application must be checked with the individual manufacturer concerned for a given installation.

The diagrams of typical constructions in this publication are for illustration only.



Company name: **British Steel Profiles
Newton Aycliffe Works
Aycliffe Industrial Estate
Co Durham DL5 6AZ**

Tel no: **01325 312343**
Fax no: **01325 313358**

Performance standard and brief detail of construction - see section 18.2 Notes for use with the proprietary data

A ½ hr - A 4 hr inc

- (a) outside rail
- (b) reference of external sheeting - Long Rib 1000w
- (c) thickness of external sheeting - 0.55mm-0.9mm
- (d) reference of internal sheeting - 1000LP
- (e) thickness of internal sheeting - 0.4mm-0.7mm
- (f) insulation - 60mm mineral wool blanket - notional density 23Kg/m³
- (g) insulation fixing - sandwiched between Zed section spacers and internal sheeting.

Note:
Detailed constructional drawings of the above data are available from the manufacturer and should be read in conjunction with the data



Company name: **CA Profiles**
Evenwood Industrial Estate
Copeland Road, Evenwood
Co Durham DL14 9SF

Tel no: **01388 834242**
Fax no: **01388 830250**

Performance standard and brief detail of construction - see section 18.2 Notes for use with the proprietary data

A ½ hr - A 4 hr inc

- (a) outside rail
- (b) reference of external sheeting - CA32, 1000w
- (c) thickness of external sheeting - 0.55mm
- (d) reference of internal sheeting - LT17/1000
- (e) thickness of internal sheeting - 0.55mm
- (f) insulation - 80mm mineral wool blanket - notional density 23Kg/m³
- (g) insulation fixing - sandwiched between Zed spacer and external sheeting.

Note:
Detailed constructional drawings of the above data are available from the manufacturer and should be read in conjunction with the data



Company name: **Euroclad Limited
Wentloog Corporate Park
Wentloog Road
Cardiff CF3 8ER**

Tel no: **01222 790722**
Fax no: **01222 793149**

Performance standard and brief detail of construction - see section 18.2 Notes for use with the proprietary data

A ½ hr - A 4 hr inc

- (a) inside rail
- (b) reference of external sheeting - Euroclad 38 or 32
- (c) thickness of external sheeting - 0.55mm or 0.7mm
- (d) reference of internal sheeting - Euroclad 20mm or 19mm liner
- (e) thickness of internal sheeting - 0.4mm
- (f) insulation - Crown³ Wool resin bonded glass fibre insulating material 60mm/80mm thick and notional density 10.5Kg/m
- (g) insulation fixing - trapped between 1.6mm 'Z' section sheeting rails and external sheeting

A ½ hr - A 4 hr inc

- (a) outside rail
- (b) reference of external sheeting - Euroclad 38 or 32
- (c) thickness of external sheeting - 0.55mm or 0.7mm
- (d) reference of internal sheeting - Euroclad 20mm or 19mm liner
- (e) thickness of internal sheeting - 0.4mm
- (f) insulation - Crown³ Wool resin bonded glass fibre insulating material 60mm/80mm thick and notional density 10Kg/m
- (g) insulation fixing - trapped between 'Z' section horizontal battens and external sheeting (battens fixed to sheeting rails via special spacers)

A ½ hr - A 4 hr inc

- (a) inside rail
- (b) reference of external sheeting - Euroclad 38 or 32
- (c) thickness of external sheeting - 0.55mm or 0.7mm
- (d) reference of internal sheeting - Euroclad 20mm or 19mm liner
- (e) thickness of internal sheeting - 0.4mm
- (f) insulation - Rocksil insulation mat 60mm/80mm thick and notional density 18Kg/m³
- (g) insulation fixing - trapped between 1.6mm 'Z' section specifically formed sheeting rails and the internal lining with insulating strips between the rails and external lining

A ½ hr - A 4 hr inc

- (a) outside rail
- (b) reference of external sheeting - Ultraspan 38mm/ 32mm
- (c) thickness of external sheeting - 0.55mm or 0.7mm
- (d) reference of internal sheeting - Ultraspan 20mm or 19mm liner
- (e) thickness of internal sheeting - 0.4mm
- (f) insulation - Rocksil insulation mat between 60mm/80mm thick and notional density 18Kg/m³
- (g) insulation fixing - trapped between 1.6mm 'Z' section specially formed battens and the internal lining (in turn fixed to the rails) with insulating strips between the battens and external lining.

Note:

Detailed constructional drawings of the above data are available from the manufacturer and should be read in conjunction with the data



Company name: **European Profiles
Llandybie
Ammanford
Dyfed SA18 3JG**

Tel no: **01269 850691**
Fax no: **01269 851096**

Performance standard and brief detail of construction - see section 18.2 Notes for use with the proprietary data

A ½ hr - A 4 hr inc

- (a) outside rail
- (b) reference of external sheeting - EP 900/26
- (c) thickness of external sheeting - 0.7mm
- (d) reference of internal sheeting - EP Lining Panel 900/19
- (e) thickness of internal sheeting - 0.4mm
- (f) insulation - 60mm mineral wool blanket - notional density 23Kg/m³ and mineral wool strips at spacers
- (g) insulation fixing - sandwiched between spacers and external sheeting.

A ½ hr - A 4 hr inc

- (a) inside rail
- (b) reference of external sheeting - EP 900/26
- (c) thickness of external sheeting - 0.7mm
- (d) reference of internal sheeting - EP Lining Panel 900/19
- (e) thickness of internal sheeting - 0.4mm
- (f) insulation - 60mm mineral wool blanket - notional density 23Kg/m³ and mineral wool strips at spacers
- (g) insulation fixing - sandwiched between rail and external sheeting.
- (h) limited to cold formed 'Z' section rails

Note:

Detailed constructional drawings of the above data are available from the manufacturer and should be read in conjunction with the data



A ½ hr - A 4 hr inc

- (a) Structural Liner Tray System
- (b) reference of external sheeting - EP Vertical Cladding (900/26)
- (c) thickness of external sheeting - 0.7mm
- (d) reference of internal sheeting - EP Structural Liner Tray (EP 600)
- (e) thickness of internal sheeting - 0.75mm-1.00mm, dependent on span
- (f) insulation - 80mm mineral wool slab - notional density 23Kg/m³ as infill to trays and mineral wool hot bridge barrier strips 50mm x 12mm
- (g) insulation fixing - laid into Liner Trays and sandwiched by external sheeting.

B ½ hr - B 1 hr inc

- (a) Structural Liner Tray System
- (b) reference of external sheeting - EP Vertical Cladding (900/26)
- (c) thickness of external sheeting - 0.7mm
- (d) reference of internal sheeting - EP Lining Panel (EP 600)
- (e) thickness of internal sheeting - 0.75mm-1.00mm, dependent on span
- (f) insulation - 80mm mineral wool board - ref RW5, as infill to trays and 20mm thick mineral wool board
- (g) insulation fixing - laid into Liner Trays and sandwiched by external sheeting.

FOR REFERENCE ONLY



Company name: **Precision Metal Forming**
Swindon Road
Cheltenham
Glos GL51 9LD

Tel no: **01242 527511**
Fax no: **01242 518929**

Performance standard and brief detail of construction - see section 18.2 Notes for use with the proprietary data

A ½ hr - A 4 hr inc

- (a) outside rail
- (b) reference of external sheeting - C19, C32, R32, C38A, R38A, C40, R40, C46, R46
- (c) thickness of external sheeting - 0.55mm min
- (d) reference of internal sheeting - C19, CL3/960, CL3/914, CL6/914, CL3/1000, CL3/900
- (e) thickness of internal sheeting - 0.4mm
- (f) insulation - 80mm glass wool - notional density 10.5Kg/m³
- (g) insulation fixing - sandwiched between spacers and external sheeting.

B ½ hr - B 1 hr inc

- (a) outside rail
- (b) reference of external sheeting - C19, C32, R32, C38A, R38A, C40, R40
- (c) thickness of external sheeting - 0.55mm min
- (d) reference of internal sheeting - C19, CL3/960, CL3/914, CL6/914, CL3/1000
- (e) thickness of internal sheeting - 0.4mm
- (f) insulation - 59mm mineral wool profiled slab - notional density 150Kg/m³
- (g) insulation fixing - sandwiched and clamped between internal and external sheeting.

Note:

Detailed constructional drawings of the above data are available from the manufacturer and should be read in conjunction with the data.



Company name: **TAC Metal Forming Limited**
Abbotsfield Road
Abbotsfield Industrial Park
St Helens
WA9 4HU

Tel no: **01744 818181**
Fax no: **01744 851555**
Technical fax: **01744 811505**

Performance standard and brief detail of construction - see section 18.2 Notes for use with the proprietary data

A ½ hr - A 2 hr inc

- (a) outside rail
- (b) reference of external sheeting - Metaclad C38, C34 or C26
- (c) thickness of external sheeting - 0.55mm
- (d) reference of internal sheeting - Metaclad TACTRAY 914, 1000 or 1016
- (e) thickness of internal sheeting - 0.4mm
- (f) insulation - 80mm Gypglass/glassfibre - notional density 10Kg
- (g) insulation fixing - sandwiched between spacer and external sheeting.

B ½ hr - A 2 hr inc

- (a) inside rail
- (b) reference of external sheeting - Metaclad C38, C34 or C26
- (c) thickness of external sheeting - 0.55mm
- (d) reference of internal sheeting - Metaclad TACTRAY 914, 1000 or 1016
- (e) thickness of internal sheeting - 0.4mm
- (f) insulation - 80mm Gypglass/glassfibre - notional density 10Kg
- (g) insulation fixing - sandwiched between rail and external sheeting.

Note:

Detailed constructional drawings of the above data are available from the manufacturer and should be read in conjunction with the data



A ½ hr - A 4 hr inc

- (a) outside rail - structural liner tray system
- (b) reference of external sheeting - Metaclad C38, C34 or C26
- (c) thickness of external sheeting - 0.55mm
- (d) reference of internal sheeting - Metaclad TACTRAY 90
- (e) thickness of internal sheeting - 0.75, 1.00 or 1.25mm dependent on span required
- (f) insulation - Alpha 500H mineral wool 75mm thick
- notional density 23Kg/m³ and mineral wool fillets at joint positions between the internal and external sheeting, fillets 12mm thick
- (g) insulation fixing - Alpha 500H cut and fitted into liner trays and sandwiched between internal and external sheeting, joint fillets fixed to flanges of TACTRAY 90
- (h) internal trays rivetted together at larger edges, steel rivets at 600mm centres

B ½ hr

- (a) inside rail or outside rail
- (b) reference of external sheeting - Metaclad C38, C34 or C26
- (c) thickness of external sheeting - 0.55mm
- (d) reference of internal sheeting - Metaclad TACTRAY 914, 1000 or 1016
- (e) thickness of internal sheeting - 0.44mm
- (f) insulation - 50mm mineral wool insulating material - notional density 90Kg/m³ - 6mm TACboard sandwiched between spacer/rail and external sheeting. All vertical and horizontal joints are to be covered with 75mm wide TACboard fillets.
- (g) insulation fixing - mineral wool sandwiched between rail or spacer and internal lining, TACboard screw fixed to rail or spacer

B 1hr - B 2 hr inc

- (a) inside rail
 - (b) reference of external sheeting - Metaclad C38, C34 or C26
 - (c) thickness of external sheeting - 0.55mm
 - (d) reference of internal sheeting - Metaclad TACTRAY 914, 1000 or 1016
 - (e) thickness of internal sheeting - 0.4mm
 - (f) insulation - wire mesh reinforced mineral wool insulating material 30mm for one hour and 50mm for two hours - notional density 90Kg/m³ at mid-cavity position. 9mm TACpanel behind external and internal lining supported in galvanised H bars
 - (g) insulation fixing - mineral wool hung centrally between rails
 - (h) All horizontal TACfire joints are to be protected by 12.5mm thick Rocklam FT strips
-



Company name: **Ward Building Components
Sherburn
Malton
North Yorkshire YO17 8PQ**

Tel no: **01944 710591**
Fax no: **01944 710555**

Performance standard and brief detail of construction - see section 18.2 Notes for use with the proprietary data

A ½ hr - A 2 hr inc

- (a) outside rail
- (b) reference of external sheeting - Moduclad 25/1250, 32/1250, 37/1200
- (c) thickness of external sheeting - 0.5mm-0.7mm
- (d) reference of internal sheeting - Moduclad Liner Panel LA1250, 1200
- (e) thickness of internal sheeting - 0.4mm
- (f) insulation - 80mm glass wool insulating material - notional density 10.5Kg/m³
- (g) insulation fixing - sandwiched between spacers and external sheeting
- (h) trade reference - Ward Firewall

A 1 hr - A 2 hr inc

- (a) inside rail
- (b) reference of external sheeting - Moduclad 25/1250, 32/1250, 37/1200
- (c) thickness of external sheeting - 0.5mm-0.7mm
- (d) reference of internal sheeting - Moduclad Liner Panel LR1250, 1200
- (e) thickness of internal sheeting - 0.4mm
- (f) insulation - 80mm glass wool insulating material - notional density 10.5Kg/m³
- (g) insulation fixing - sandwiched between rails and external sheeting
- (h) trade reference - Ward Firewall

Note:

Detailed constructional drawings of the above data are available from the manufacturer and should be read in conjunction with the data



Metal Cladding & Roofing Manufacturers Association Limited
106 Ruskin Avenue Rogerstone Newport Gwent NP10 0BD

01633 895633 info@mcrma.co.uk www.mcrma.co.uk

