

FOCUS ON INDUSTRIAL GUTTERING



MGMA Information Sheet No 05

July 2013

INTRODUCTION

Gutters were first used in the Industrial Revolution thanks to the invention of cast iron. Subsequent developments in technology eventually led to the manufacture of gutters in steel. The first official British Standard specification for pressed steel gutters was published in 1946 and was updated in 1963 as BS 1091.

The draft standard, BS 9101 will replace the old standard as new technology has meant that thinner materials and different coatings have the same properties, if not better, than the original heavier items that are specified in BS 1091.

The requirement for industrial gutters has grown over the decades to meet the demands for larger buildings following the expansion of logistics parks, industrial estates, business parks, recreational and commercial centres.

MATERIAL COMPOSITION (GUTTERS)

The thickness and type of material will depend on the application.

Material	Standard	Typical Thickness
Galvanised steel - G275	BS EN 10346	1.6, 2.0 and 3.0mm
Galvanised steel - G600	BS EN 10346	3.0, 4.0 and 6.0mm
Plastisol	EN 13523	0.7mm
Aluminium	BS EN 485	1.6, 2.0 and 3.0mm
Membrane	BS EN 10147	1.2mm minimum
Stainless Steel	BS EN 10088-2:2005	1.6, 2.0 and 3.0mm

Coating	Standard	Thickness	Service Life (Years)
Galvanised Before Manufacture	BS EN 10346	G275 G600	Determined by ISO 14713-1
Galvanised After Manufacture	BS EN ISO 1461	≥1.5 to 3mm - 55µm >3 to ≤6 mm - 70µm	Determined by ISO 14713-1
Plastisol	EN 13523	200µm	40
Emaline (High Build Bitumous Coating)	-	250 - 500µm	-
Bitumen	-	100 - 1000µm	25
PPC	BS 6496 aluminium BS 6497 galvanised	40 - 70µm	25
TPO Coating	-	100 - 300µm	25
PVC Membrane	-	400 - 1500µm	Minimum 10
TPO Membrane	-	800 - 1200µm	Minimum 10

Insulated gutters

When gutters are to be insulated this can be done on site during the installation process, however, this process is usually performed in the factory environment whilst the gutters are being manufactured.

The insulation used to give the thermal performance to the gutter is predominantly PIR or Mineral Wool in composition.

To complete the process and retain the insulation in place a white liner tray is attached to the gutter to give an aesthetic appearance inside the building when it is complete.

Thermal performance

All internal gutters must be thermally insulated. This means taking care with air and vapour sealing and the avoidance of thermal bridges. The integrity of the vapour control layer and air leakage barriers must be maintained throughout the roof and gutter areas. The gutter edge should be designed to make sealing a simple procedure.

To minimise the risk of condensation of gutters within the building the thermal performance of the gutters must be lower than the performance of the roof.

History has proved that in colder periods the outlets may freeze and the gutters become full of snow and ice. It is critical that the roof as a whole does not begin to thaw until the outlets and the ice and snow in the gutters has thawed allowing the gutters to flow freely. As the roof begins to thaw the water flows without restriction and the gutters perform as designed.

Therefore, gutters should be classed as a ψ (psi)-value not a U-value! To eliminate the risk of condensation the f-factor needs to be calculated. The following table determines the minimum f-factor for each building type, in accordance with BS 5250.

Humidity Class	Minimum f-factor	Building Type
1	0.30	Storage areas
2	0.50	Offices, shops
3	0.65	Dwellings with low occupancy
4	0.80	Sports halls, kitchens, canteens, buildings heated with un-flued gas heaters
5	0.90	Swimming pools, laundries, breweries

Note: All standards referenced in this document are current at the time of publication

LOCATION ON BUILDING

Valley gutters

These have to be fitted at an early stage of construction that is, immediately after the main frame or phased whilst the roof cladding is progressing.

The gutters are usually factory insulated; however, single skin gutters can be site insulated.

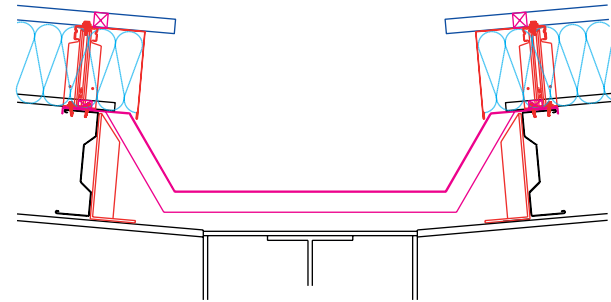

Boundary gutters

These have to be fitted at an early stage of construction that is, immediately after the main frame or phased whilst the roof cladding is progressing.

The gutters are usually factory insulated; however, single skin used on projected eaves or on a canopy can be site insulated.

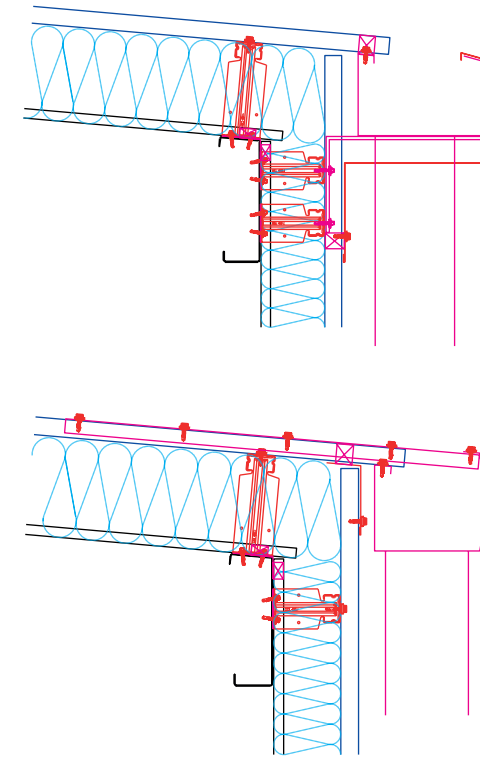
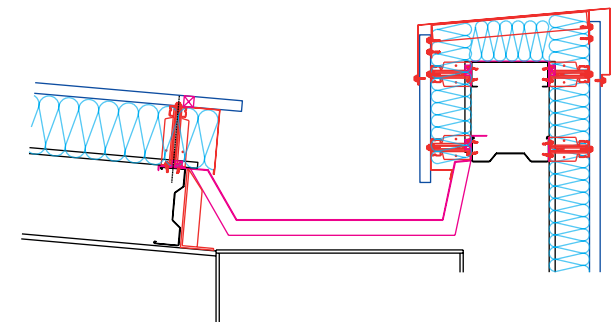
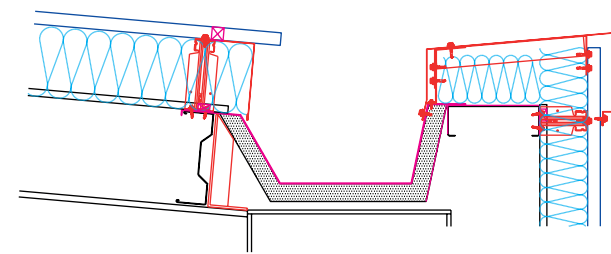

External eaves gutters

External eaves gutters are usually outside the building envelope and are often erected during the latter stages of construction. These can be supported by gutter arms under the sole of the gutter or, alternatively, supported arms projecting from the roofing profile.

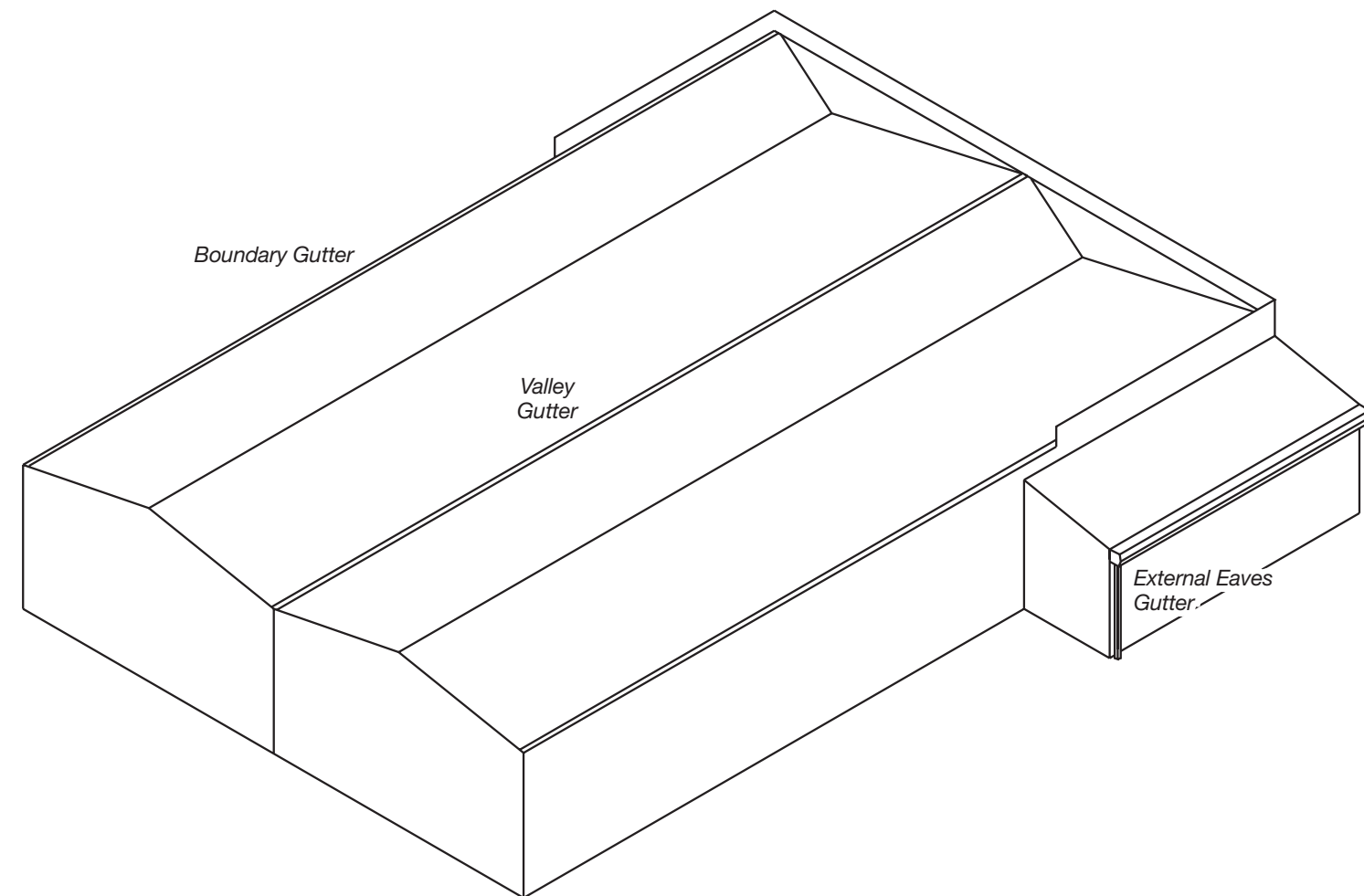

JOINT INSTALLATION METHODS

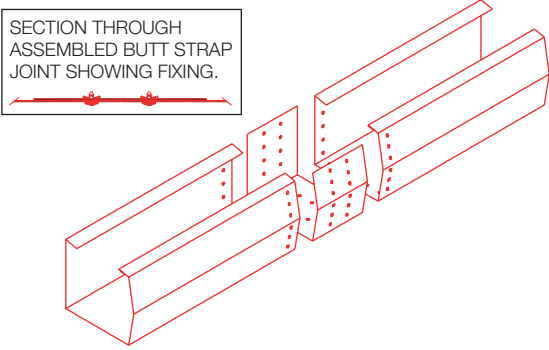
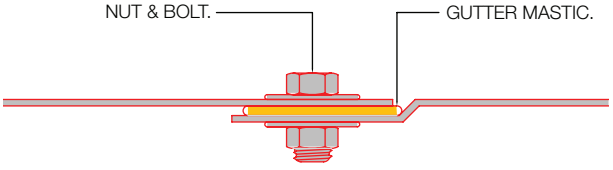
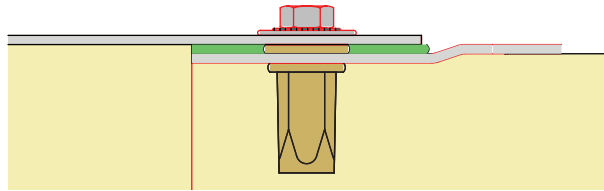
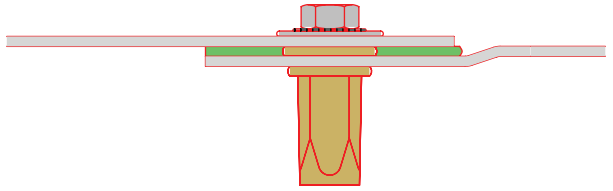
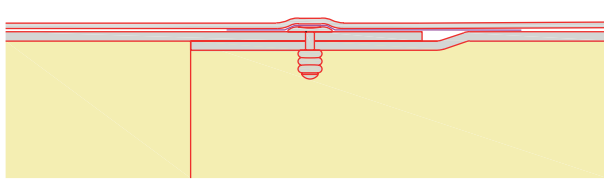
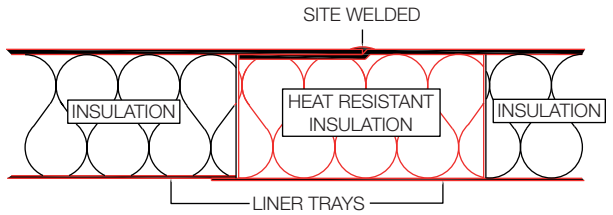
 <p>SECTION THROUGH ASSEMBLED BUTT STRAP JOINT SHOWING FIXING.</p>	 <p>NUT & BOLT. GUTTER MASTIC.</p>
<p>Fascia Gutters – are external of the building envelope with a riveted butt strap joint. The butt strap should be sealed at either side of the fixing line with sealant and the reverse of each rivet should also have a ‘blob’ of sealant to prevent water drips from the fixings</p>	<p>Bolted – Single Skin – fixings should always be installed from the centre of the gutter out. The strip mastic should be applied to a clean dry surface and pierced to allow the bolt to be installed. When tightening the nut and bolts, ensure that the mastic exudes from the joint, however, do not over tighten creating metal to metal contact</p>
	
<p>Bolted – Captive Nut – fixings should always be installed from the centre of the gutter out with this application allowing the gutter to be installed from the top side only. The strip mastic should be applied to a clean dry surface and pierced to allow the bolt to be installed. When tightening the bolt and washers, ensure that the mastic exudes from the joint and do not over tighten therefore stripping the system</p>	
	 <p>SITE WELDED INSULATION HEAT RESISTANT INSULATION INSULATION LINER TRAYS</p>
<p>Welded Membrane – pre laminated membrane gutters should have a riveted joint overlaid with foil tape offering a ‘weld free zone’ under the membrane joint. The membrane joint should be fully welded (back and securing welds) with no creases or ash present, greater than the minimum requirement</p>	<p>Site Welded – if materials are to be site welded it must be ensured that heat resistant insulation is placed under the joint to be welded during construction. In addition thermal expansion should be considered for in the gutter run when using this method</p>

Visit our web site

At www.mgma.co.uk you can contact MGMA members and discover the products and services available. Members are only too pleased to help with any problems you have and can provide design assistance should you need it.

Whilst the information in this data sheet is believed to be correct at the time of going to press, the Metal Gutter Manufacturers Association and its member companies cannot be held responsible for any errors or inaccuracies and, in particular, the specification for any application must be checked with the individual manufacturer concerned for a given installation.

Metal Gutter Manufacturers Association

106 Ruskin Avenue
Rogerstone Newport
South Wales
NP10 0BD

01633 891584
mgmagutters@gmail.com
www.mgma.co.uk

