

Under Review

COMPOSITE ROOF AND WALL CLADDING PANEL DESIGN GUIDE



1.0 Introduction

CONTENTS

	Page
1.0 Introduction	1
2.0 Materials	1
2.1 Facings	1
2.2 Coatings	1
2.3 Insulation	1
3.0 Manufacture	2
3.1 Press injection	2
3.2 Continuous lamination	2
3.3 Adhesive lamination	2
4.0 Performance	3
4.1 Thermal insulation	3
4.2 Performance in fire	3
4.3 Acoustics	4
4.4 Durability	4
5.0 Roof panels	5
5.1 Introduction	5
5.2 Appearance and specification	5
5.3 End laps	5
5.4 Side laps	6
5.5 Fasteners	6
5.6 Construction details	6
5.7 Structural performance	7
5.8 Fire	7
5.9 Penetrations	8
6.0 Rooflights	8
6.1 Introduction	8
6.2 Construction	8
6.3 Strength	9
6.4 Thermal transmittance	9
6.5 Fire	9
7.0 Wall panels	10
7.1 Introduction	10
7.2 Panel specification	10
7.3 Panel appearance	10
7.4 Panel side joints	11
7.5 Curved and cranked panels	11
7.6 Panel fixings	12
7.7 Construction details	12
7.8 Structural performance	13
7.9 Fire	13
8.0 Windows	13
9.0 Site considerations	16
9.1 Site storage	16
9.2 Handling	16
9.3 Health and safety	16
9.4 Repairs	16

When any thin skins are bonded to a lightweight core, a sandwich or composite panel is formed. By assembling individually flexible materials in this way, very light but rigid panels are created, optimising the properties of each component.

One of the early applications which made use of this type of construction was the Mosquito aircraft in the 1940s. Here, thin plywood skins were bonded to a balsa wood core to form the fuselage. Many aircraft components still use the same technology today, often using aluminium skins and honeycomb core.

The same basic construction is now used in a great variety of other applications from sophisticated space craft to relatively 'low tech' domestic doors.

A large range of materials can be used but if metal sheets are combined with a core which has good thermal insulation properties the composite panel formed is an ideal building element for roof and wall cladding (see figure 1).

By using standard pre-finished metal facings, already commonly used as cladding sheets, a factory-finished composite cladding panel can be made. This one-piece product combines a lining sheet, insulation and outer sheet, so it can be quickly and simply fixed on site, providing both high quality and reliability. This type of panel was first manufactured in the 1960s and its share of the market has grown steadily all over the world ever since.

Today the panels are used for cladding the roofs and walls of many industrial and commercial buildings.

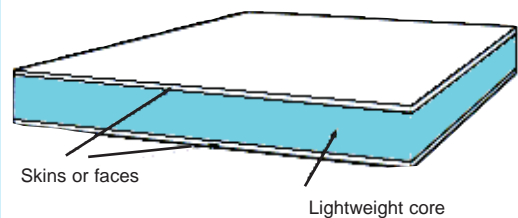

Fig. 1 COMPOSITE PANEL

2.0 Materials

Composite cladding panels consist of pre-coated external and internal metal facings which are bonded to a rigid insulation core.

2.1 Facings

Composite cladding panels have facings made of steel to BSEN 10147 or aluminium to BS 1470.

Thicknesses vary from product to product depending on application but the following are generally regarded as minimum thicknesses:

	Steel	Aluminium
Outer sheet	0.5	0.7
Inner sheet	0.4	0.5

Profiles vary depending on application and manufacturer. See section 5.0 for roof panels and section 7.0 for wall panel examples.

2.2 Coatings

All steel faces are hot dip galvanised or aluzinc coated and painted to provide the required appearance and durability, and to facilitate bonding to the insulation core.

Aluminium is available with a mill or painted finish but in both cases, the reverse side is primed for the bonding process.

The following coatings are commonly available. Individual manufacturers may offer others.

Type	Typical thickness (microns)
Plastisol (steel)	200 (weather sheet)
PVF2 (steel & aluminium)	25 (weather sheet)
Multi-coat systems (steel & aluminium)	100 (weather sheet)
ARS (aluminium)	28 (weather sheet)
Polyester (steel & aluminium)	22 (liner sheet)

Note that the standard liner specification is for normal internal environments. Higher specification coatings should be used where there are aggressive environments, or where hygienic finishes are required. Full details of the range of available coatings can be obtained from the individual manufacturers.

2.3 Insulation

There are a number of insulation materials which can be used to make composite cladding panels:

- Rigid polyurethane (PUR)
- Rigid polyisocyanurate (PIR)
- Extruded polystyrene (EPS)
- Expanded polystyrene (XPS)
- Phenolic foam
- Mineral fibre

Of these, only rigid polyurethane and polyisocyanurate insulation (collectively called urethanes) expand and autohesively bond to the metal faces during the manufacturing process. A separate adhesive has to be used to bond the other insulation materials.

The autohesive properties make urethane particularly suitable for filling panel profiles and edge details and it is therefore the most commonly used core for composite cladding panels.

All the rigid foam insulation materials are produced using chemical blowing agents. In some cases a chlorofluorocarbon (CFC11) was traditionally used but this has now been phased out in accordance with the Montreal Protocol.



3.0 Manufacture

Rigid urethane filled composite panels can be manufactured either by press injection of individual panels, or by continuous lamination. An adhesive bonding process can be used to make panels with any of the insulation materials.

3.1 Press injection

In this process, the individual outer and liner sheets are prepared and then installed in a jig or press, creating a cavity between the faces.

The urethane core is made by mixing special liquid components and then injecting the mixture into the panel cavity. The chemicals react together and form the insulation which expands throughout the cavity, filling it completely. When the core has cured, the completed panel is removed from the press (see figure 2).

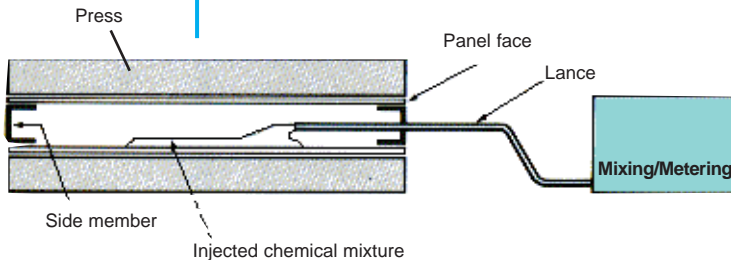

Fig. 2 PRESS INJECTION

3.2 Continuous lamination

In this case, the panels are made continuously on a large machine. Outer and liner faces are decoiled and roll formed continuously to the required profile. They are then pre-heated before passing the laydown gantry, which lays down precise quantities of chemical mixture onto the outer sheet as it progresses along the machine. Immediately afterwards the liner and the outer sheet converge

into the laminator and the expanding insulation rises to fill the cavity. The core cures as the panel progresses through the laminator and, when it emerges, the panel is cut to the required length.

Whilst this process involves a large machine, it is the most economic way of making large volumes of cladding panels (see figure 3).

3.3 Adhesive lamination

This process is used to bond a liner sheet, a slab of insulation and an outer sheet together using a separate adhesive. It is predominantly used to make 'architectural' wall panels with flat or finely ribbed faces. The panels are normally made in lengths up to approximately 4m.

Adhesive is applied to the individual components which are then carefully assembled. The manufacturing process is normally completed by clamping the panels in a press or by passing them through nip rollers.

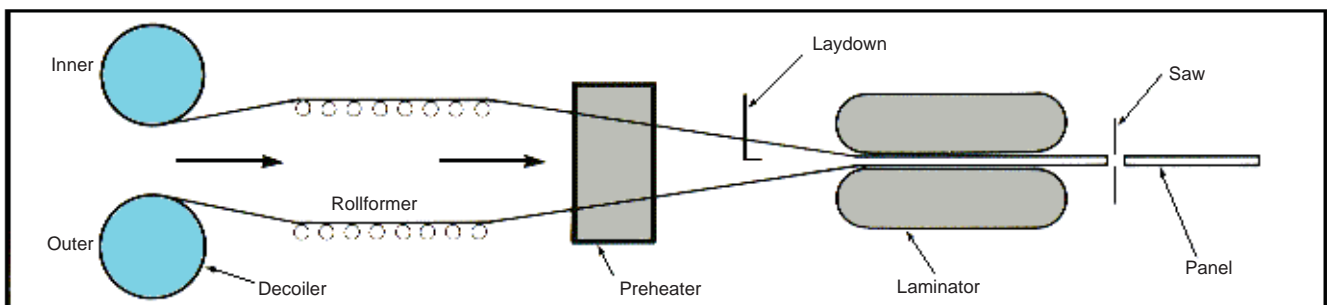

Fig. 3 CONTINUOUS LAMINATION



4.0 Performance

A number of aspects of composite cladding panel performance are common to both roofs and walls - these are detailed below. Items which are specific to either roofs or walls are shown in sections 5.0 and 7.0.

4.1 Thermal insulation

Urethane is one of the best thermal insulation materials available, so it is possible to achieve very low U values (thermal transmittance) with relatively thin panels.

Material	Approximate insulation thickness (mm)* required for U value of 0.45 W/m ² K
Urethane insulation	45
Extruded polystyrene	55
Expanded polystyrene	70
Phenolic foam	45
Glass or mineral fibre	80

* Actual thickness depends on particular blowing agent used.

As some of the panels are available in long lengths, it is possible to keep the number of joints and cold bridges to an absolute minimum. Tests have been arranged by the MCRMA to determine the heat loss through panels and fasteners. The tests have shown that through fasteners in typical installations have a negligible effect on the U value of the panels.

Continuously laminated, press injected and bonded flat composite panels made with rigid foam insulation are completely filled, with no voids or passages for air to flow through. The faces are impermeable so moisture vapour cannot enter the panels and interstitial condensation cannot occur within individual panels.

As with all types of construction, care is still required when detailing joints and junctions to minimise air leakage and ensure continuity of the thermal insulation in accordance with the 1995 issue of Approved document L. See section 5.0 for roofs and section 7.0 for walls.

4.2 Performance in fire

Although the panels may contain combustible cores, the metal faces protect the core from direct flames and panels will normally achieve the following classifications:

BS476 Part 3 - Roof external exposure	FAA/SAA
BS476 Part 6 - Propagation	1 < i, < 6
BS476 Part 7 - Surface spread of flame	Class 1
Building Regulations	Class 0
BS476 Part 20 - Fire resistance	Performance in this test depends largely on the insulation used, the panel joint details and the fixing arrangement. Insulation periods of approximately 5 to 15 minutes are possible, but some panels can be detailed to provide stability and integrity for longer periods.

The panels can be used in many situations

but normally if a period of fire resistance is required, special details or additional layers need to be built into the construction. Specific details can be obtained from individual manufacturers.

See also MCRMA technical paper No. 7 - 'Fire design of steel sheet clad external walls for building: construction performance standards and design'



4.3 Acoustics

Composite panels are inherently light and rigid so their ability to reduce sound transmission is limited. A typical graph showing Sound Reduction Index (SRI) vs frequency is shown below, giving a single figure weighted Sound Reduction Index (Rw) of 26dB (see figure 4).

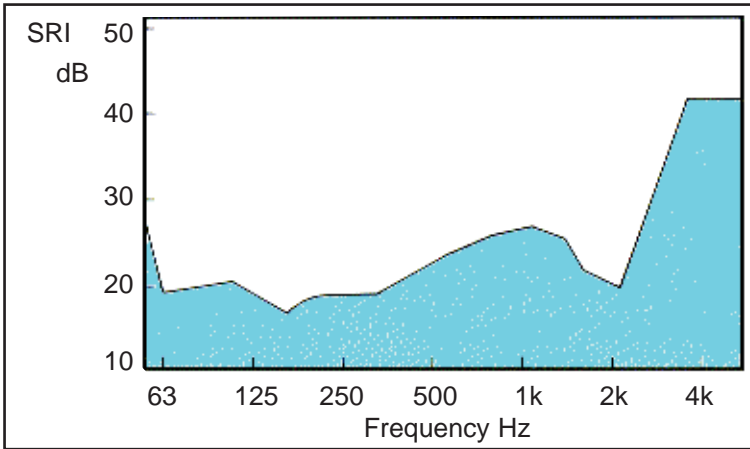

Fig. 4 TYPICAL SOUND REDUCTION INDEX

Similarly the absorption coefficient is typically as follows (see figure 5).

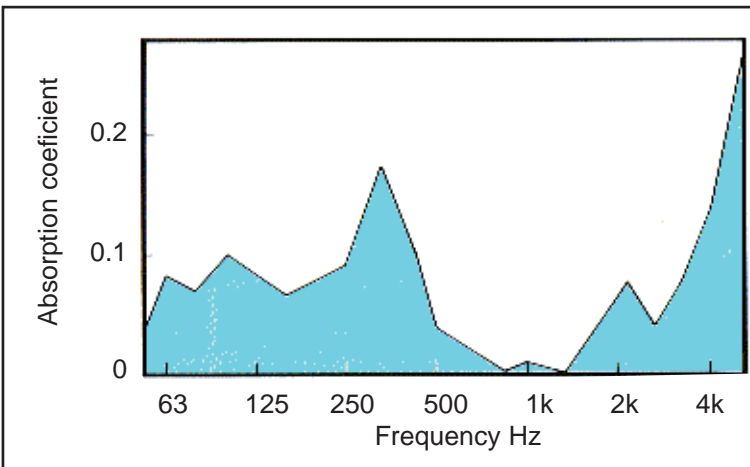

Fig. 5 TYPICAL ABSORPTION COEFFICIENT

The SRI values can be improved significantly (eg $R_w = 40$) by incorporating additional sheet material (with or without perforations to improve absorption), air spaces and fibrous insulation (see figure 6).

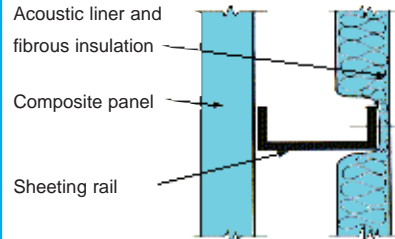

Fig. 6 IMPROVED SRI VALUES

Note that sound 'leaks' through gaps around windows and doors etc. and through rigid connections, in a similar way to heat conduction through cold bridges, so attention to detail is important if acoustic design values are to be achieved in practice.

For detailed guidance refer to MCRMA technical paper No. 8 - 'Acoustic design guide for metal roof and wall cladding systems'

4.4 Durability

In normal circumstances, the durability of panels depends on the environment, coating performance and routine maintenance. The insulation core provides consistent performance throughout the life of the panel.

All coatings will gradually degrade when exposed to the elements. The rate will depend on how severe the environment is in terms of UV radiation, industrial or marine air pollution, the presence and retention of moisture, and the colour itself.

Each manufacturer quotes durability of coatings in years, from 10 to 25 years, depending on the factors above. This normally refers to the coated areas of the panels, not the cut edges, which will deteriorate more quickly. For optimum long term durability of any steel cladding the exposed cut edges must be treated.

Furthermore, the whole building should be inspected annually, any accumulation of debris should be removed from roofs and the panels should be cleaned and touched-up when necessary.



5.0 Roof panels

5.1 Introduction

Composite roof panels are suitable for most applications where lightweight construction is required and some panel designs can be used on finished roof slopes down to 1° (after all deflections).

The one piece, factory produced panel is supplied in pre-cut lengths to suit the building's dimensions. The ends and sides of the panels are prepared in the factory so that secure, weathertight joints can be formed on site with the minimum of difficulty. The panels are fixed to the support structure, usually steel purlins, by means of self-drilling/self-tapping screws. Most panels are capable of interlaying with typical roofing accessories such as rooflights, apertures and gutters.

5.2 Appearance and specification

Roof panel systems fall into two distinct categories.

1. Through-fixed panels comprise a trapezoidal outer sheet with conventional side and end lapping methods suitable for roofing down to 4° pitch.
2. Panels for use on finished pitches down to 1° employ outer profiles designed to have concealed fixings and take the side joints above the level of water drainage. Ideally these panels should be used in single lengths, from ridge to eaves to avoid the use of end laps (see figure 7).

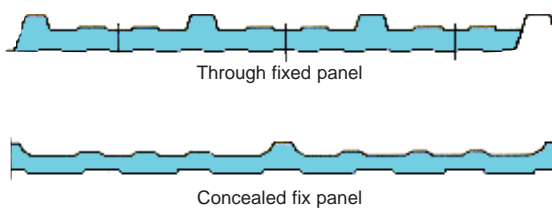

Fig. 7 ROOF PANEL SYSTEMS

Typical roof panels consist of an 0.5mm to 0.7mm pre-coated steel or an 0.7mm to 0.9mm aluminium weather sheet. The inner steel or aluminium sheet is usually lightly profiled with a white surface coating to provide a decorative finish.

Panels are available in increments of thickness, usually between 40mm and 100mm to provide a range of thermal performance and panel strengths to suit most building requirements. The minimum panel thickness in the range usually provides an insulation value ($U = 0.45W/m^2K$) to comply with current Building Regulations.

The panel module or cover width may vary according to panel type and manufacturer, but is usually between 900mm and 1200mm (see figure 8).

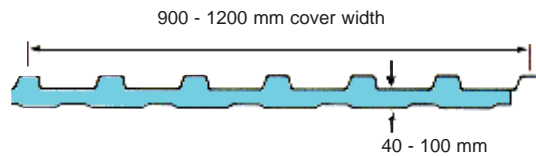

Fig. 8 TYPICAL PANEL DIMENSIONS

Panel length is generally restricted by transportation and/or site access requirements rather than manufacture. Panel lengths up to 14 metres are considered typical however, some panels are available in lengths up to 30 metres. When fitting these panels it is essential to use the correct site handling methods recommended by the manufacturer.

Panel weight varies depending on the material and thickness of the metal inner and outer skins and the thickness of the insulation, giving a normal weight range in the region of 10-15 kg/m² for steel facings and 6-10 kg/m² for aluminium.

5.3 End laps

Roof panels are supplied in pre-cut lengths with the inner skin and insulation cut back to form an end lap or drip edge at the eaves if required. Normally no further protection to the exposed core is necessary at eaves or valley conditions (see figure 9).

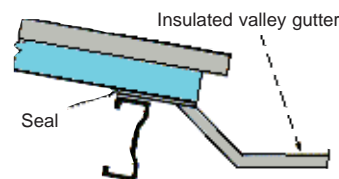

Fig. 9 EAVES CUT BACK

Typical end lap joints require sealant and fixings to form a weathertight joint. Note that end laps should be avoided if at all possible on roof slopes less than 4° (see figure 10).

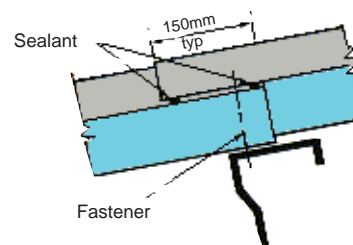

Fig. 10 TYPICAL END LAP

5.4 Side laps

Panel side jointing methods depend on the particular type of panel. Through-fixed panels have an overlapping side lap which must be weather sealed on sit and fixed with stitching screws, typically at 400 mm centres (see figure 11).

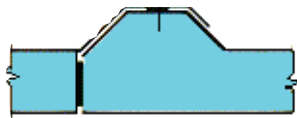

Fig. 11 **SIDE LAP JOINTS - OVER 4°**

Concealed-fix panels may overlap or butt together at the panel sides and the joint is covered with a separate cap (see figure 12).



Fig. 12 **SIDE LAP JOINTS - SLOPES GREATER THAN 1°**

5.5 Fasteners

Fasteners through the panel are normally self drilling and tapping. They incorporate a washer to compress to the outer skin to ensure a weathertight seal and a 'high' thread which supports the outer sheet. Panels may be fixed through the valley or crown of the profile. Note that the fasteners must not be under or over tightened to achieve the correct seal (see figure 13).

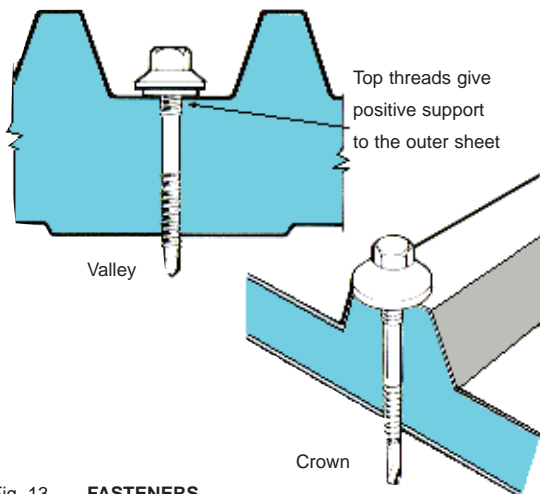

Fig. 13 **FASTENERS**

5.6 Construction details

The typical details shown in this section illustrate various common junctions (see figures 14, 15 and 16). Proprietary systems may have particular requirements and the manufacturer's recommendations should always be followed.

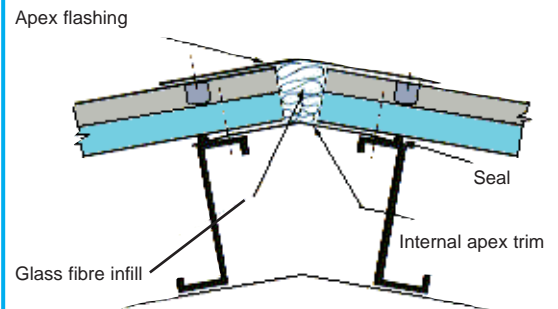

Fig. 14 **APEX DETAIL**

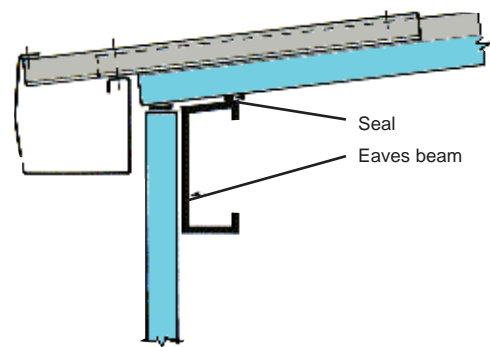

Fig. 15 **EAVES DETAIL**

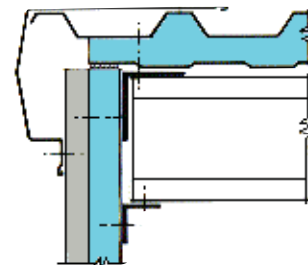

Fig. 16 **VERGE DETAIL**



5.7 Structural performance

5.7.1 Load span tables

The roof panel's structural performance depends on the two metal faces and the core acting together to form a composite element.

In general, the composite strength of the panel, when fixed to supports at conventional spacings of typically 2m, is more than adequate to resist normal snow, wind and construction loadings. On any project the structural engineer is responsible for defining and specifying the loadings and support centres for the cladding. The maximum purlin spacing depends on the spanning ability of the roof panel. Imposed loadings should be taken from BS6399 Parts 1 and 3 and wind loadings from CP3 Chapter V Part 2.

Consideration should be given to areas where snow drifting may occur, such as behind parapets or in valleys, and areas where wind uplift loads may be high, at the ridge, verge and eaves. Here fastener strength is likely to be critical.

Load tables published by the manufacturer should be based on the ECCS Recommendations and show the permissible loadings for the roof panel to resist snow, wind suction and wind pressure, taking the effects of internal and external temperatures into account. Single span, double or multi-span conditions are usually stated, together with the appropriate limiting deflection criteria.

Temperature loading is particularly important because it causes thermal bow both along the length and across the width of the panel between fixings, creating significant stress in the facings. Generally, dark colours can reach higher temperatures and exacerbate the thermal bowing effect.

5.7.2 Panel support

The support purlins must be flat, continuous and parallel to the panel plane. The alignment of the purlin flanges is normally specified as the standard BS5950 tolerance of purlin spacing/600.

Panel crushing at the support is not considered critical assuming intermediate support widths greater than 50mm are used. Detail requirements for end lapping of panels may require greater bearing width.

5.7.3 Apertures and penetrations

Holes up to 200 mm diameter to allow the exit of pipework or ducting would not normally require additional framework for support. Where larger openings for skylights, mechanical vents or other large or heavy items are required on the roof, additional framing may be required.

Effective weathering/sealing arrangements are available for all penetrations on all roof slopes. Details are available from the individual manufacturer.

5.7.4 Panel fixing

Specific fixing methods have been developed to deal with the forces imposed on the panel facings and core. In all cases, the panel manufacturer's recommendations of fixing screw or patent fixing method must be adopted.

As with conventional roofing, consideration must be given to increased fixing capacity in areas of high local wind uplift.

5.7.5 Purlin restraint

Where a patent fixing method is used or where panels are fixed at the edge only, the lateral restraint to the purlin must be considered.

5.8 Fire

Under the Building Regulations, roofs are not normally required to provide fire resistance as defined by BS476 Part 22. Roof panels should, however, resist penetration by fire from the outside and limit the spread of flame on the surfaces.

Composite cladding panels satisfy the above requirements by providing an AA classification to BS476 Part 3 and a Class O surface, as defined by the Building Regulations. Class O designation is gained by ensuring satisfactory test ratings from fire tests to BS476 Parts 6 and 7.

Composite roof panels may require additional protection at junctions between a roof and a separating wall to a distance 1.5 metres each side. Conventional fire protection boards may be considered in these areas.



6.0 Rooflights

5.9 Penetrations

Most roofs have a number of flues, chimneys or ventilator units which penetrate the weatherproof surface. These must be carefully integrated into the roof construction to avoid ponding, coating deteriorating and potential leaks.

A variety of systems are commonly used, depending on the panel profile, the roof slope and the size, shape and position of the penetration on the roof. However, they do not all complement the roof panel performance. Furthermore, some can be used during construction but are not suitable for fitting later.

The most versatile solution which can be used in every situation is the site-applied GRP soaker. This ensures good drainage around the penetration, can be used on any profile on any slope, does not require cover flashings to the ridge, can be fitted during or after construction, and is guaranteed by the manufacturer/installer. The MCRMA arranged for weathering tests to be carried out on this system and the results were favourable (see figure 17).

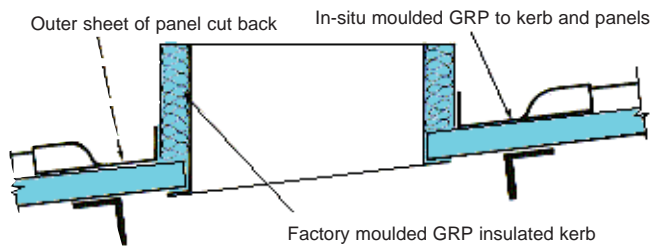

Fig. 17 TYPICAL PENETRATION DETAIL

6.1 Introduction

Rooflights are available in the form of site-assembled or factory-assembled units. Factory-assembled units have the inherent advantages of ease of installation on site and reliability.

The materials most frequently used in the construction are GRP and PVC. Other materials such as polycarbonates are available, although they are less frequently specified.

6.2 Construction

When the panel jointing method allows, the factory-assembled unit may be interlaid with the composite roof panels to form continuous or scatter pattern rooflighting (see figure 18).

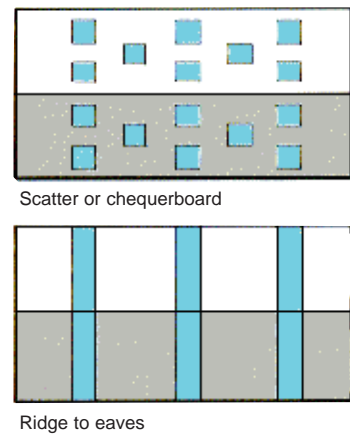

Fig. 18 TYPICAL ROOFLIGHT PATTERNS

Overlap and side lap fixing and sealing details will vary from the details adopted for the roof panel to allow for the more flexible and fragile nature of the plastics material. Larger sealant beads and fixing washer diameters may be specified to ensure long term performance. Typically fasteners would have 30mm diameter washers and be fixed in every corrugation. The sealant should always be white or light grey to minimise temperature gain and ensure maximum life.



PVC materials will also require carefully drilled oversize fixing holes to allow for thermal expansion (see figure 19).

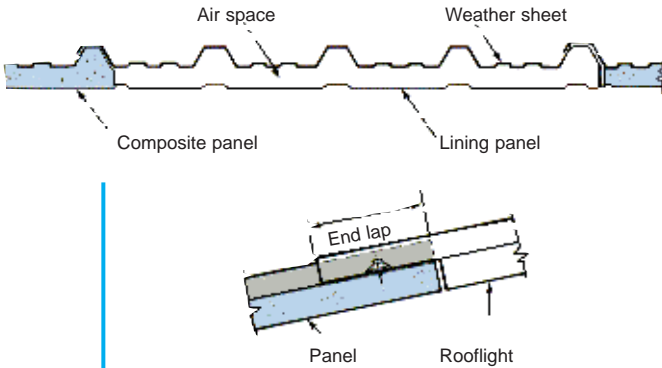

Fig. 19 **FACTORY ASSEMBLED ROOFLIGHT**

Low pitch roof systems should incorporate upstand rooflighting such as domes to ensure that the critical fixing points and laps are away from the direct water path. Rooflight patterns are normally restricted to continuous downslope lines from the ridge or in a line along the ridge (see figure 20).

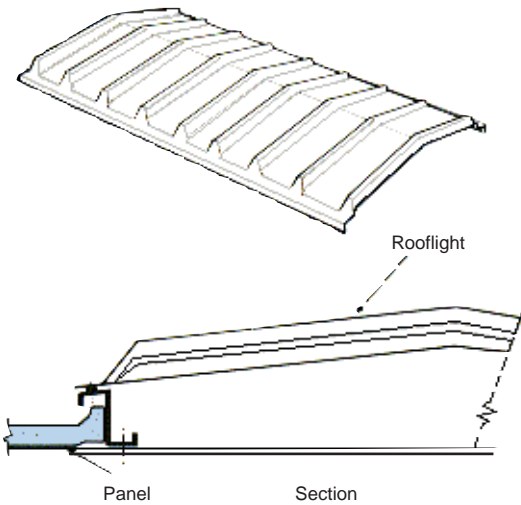

Fig. 20 **DOME ROOFLIGHT**

6.3 Strength

Rooflight materials are inherently more flexible than the roof panels. The performance of the rooflight to resist wind and snow loading is likely to be the limiting factor in the selection of purlin centres.

The spanning strength of the rooflights is dependent on the thickness (weight) of the material and profile shape. However, consideration must also be given to the strength of the material at the fasteners to resist pull over and distortion.

6.4 Thermal transmittance

For design purposes the thermal transmittance (U value) of a double skin rooflight is taken as 2.8 W/m²K. Triple skin rooflight constructions, where available, may be used and have design U values of 2.0 W/m²K.

Factory-assembled rooflight units integrate with the adjacent panel to maintain a seal at side and end lap junctions. This helps minimise the risk of condensation problems with the rooflight in normal low humidity environments.

Site-assembled double skin rooflights should be avoided since successful integration and sealing with the roof panels is difficult to achieve. This may result in consequent reduction in thermal performance and increased risk of condensation.

6.5 Fire

To comply with the requirements of the Building Regulations, GRP materials are usually required to satisfy the SAB rating to BS476 Part 3 for the outer skin and a Class 1 surface spread of flame rating to BS476 Part 7 for the inner skin of the twin skin construction. Certain applications may call for Class O rating.

PVC materials require satisfactory testing to BS 2782 method 508A and Class 1 surface spread of flame for general use as rooflights. The low melt nature of PVC can be advantageous in fire design to allow the venting of smoke, gases and heat.

See also MCRMA technical paper No. 1 - 'Daylighting recommended good practice in metal clad light industrial buildings'



7.0 Wall cladding panels

7.1 Introduction

Composite wall panels are used for the external wall cladding and fascias of buildings.

The wall panel systems can generally be laid horizontally or vertically and the external surface can be trapezoidal, micro-rib, mini-box or flat. Many systems are a secret fix design.

7.2 Panel specification

The external weather sheets are steel and aluminium with typical substrate thickness of 0.5mm to 0.7mm.

Depending on the outer sheet profile and the type of insulation, the panel thickness can range from 40mm to 100mm. The minimum panel thickness normally provides a thermal transmittance of $0.45 \text{ W/m}^2\text{K}$, conforming to the current Building Regulations. Greater core depths provide better thermal performances, increased strength and stiffness.

The composite wall panels are available in a variety of widths, ranging from 300mm up to 1200mm. Urethane insulated panels are usually supplied in lengths up to 10m, but longer panels are available from some manufacturers. Adhesive laminated panels are typically manufactured up to 4m long.

7.3 Panel appearance

The following illustrations (see figure 21) show a selection of different external panel profiles.



Flat



Mini-box

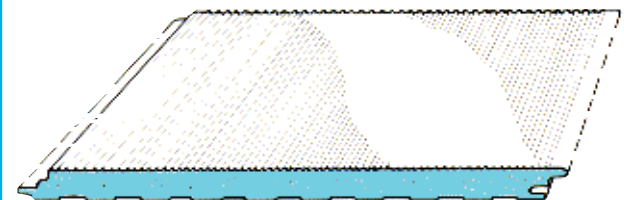

Micro-rib



Trapezoidal

Fig. 21 EXTERNAL PANEL PROFILES



7.4 Panel side joints

The composite wall panel side joint details are commonly a tongue and groove arrangement with factory applied seals, thus eliminating panel sealing on site at the joints. The side joints themselves are designed to conceal the panel fixings which can be a direct through fastener or a secret fix clip. Some typical panel joint details are illustrated below (see figure 22).

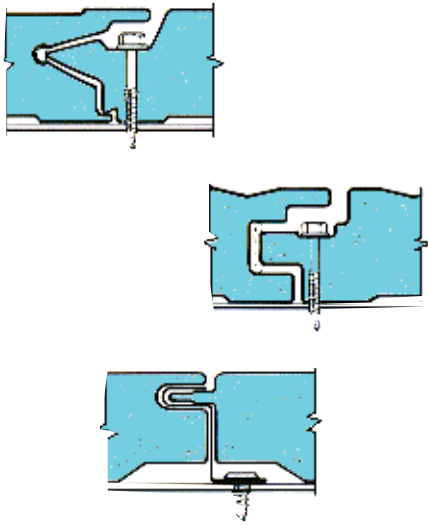

Fig. 22 PANEL SIDE JOINTS

7.5 Curved and cranked panels

Some composite wall panels can be fabricated to form cranked or curved sections.

With these units the panel edge joints are retained so that the clean appearance around the cladding envelope is maintained. The pre-formed units can eliminate traditional flashings and provide the necessary thermal insulation (see figure 23).

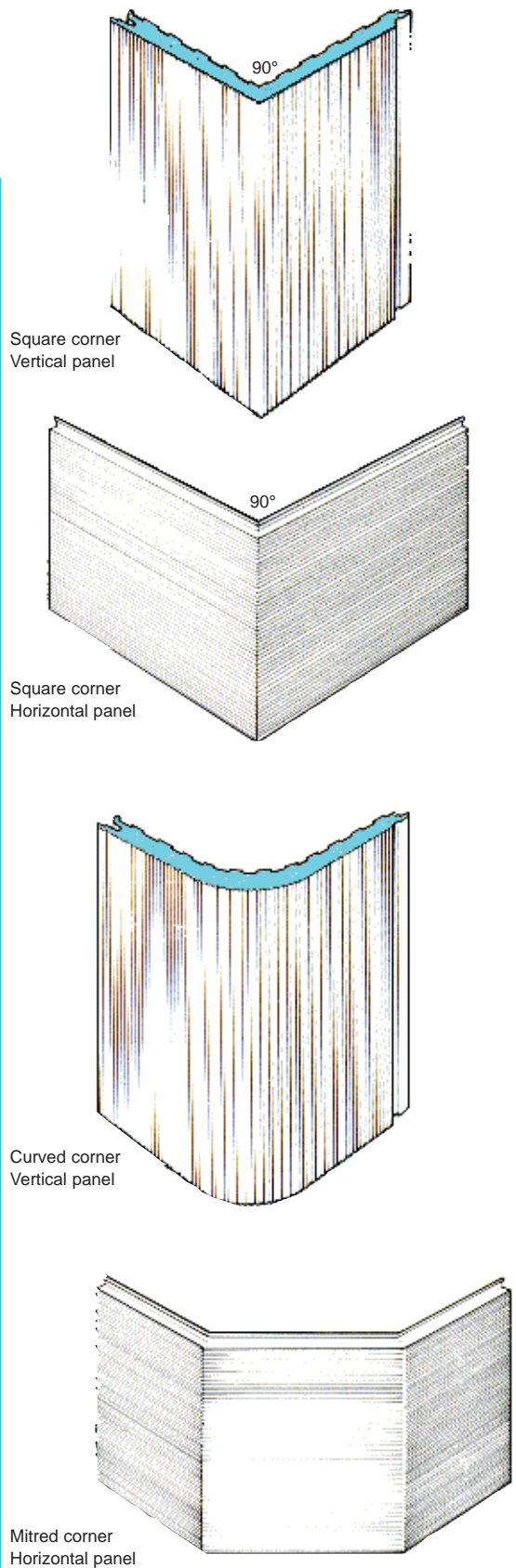

Fig. 23 CURVED AND CRANKED PANELS



7.6 Panel fixings

Wall panels can be fixed to a secondary supporting framework constructed from either hot rolled steel, cold rolled steel, concrete or timber sections. There are two methods used for fixing the panels to the secondary frame, either direct through fixings or using special panel clips which are fixed to the supports to retain the panel joint. With the through fix concept, self-drilling and tapping fasteners incorporating steel washers or washer plates are used. The frequency of panel fasteners or panel clips and the rail spacing will generally depend on the design suction loads.

Flashing or cosmetic trim features are normally fixed to the insulated wall panel by either stitching screws or rivets with matching colour caps.

7.7 Construction details

The typical construction details shown below (see figures 24-31) illustrate various panel junctions and flashing arrangements for both vertically and horizontally laid panel systems.

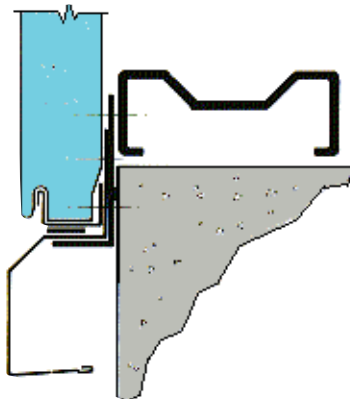

Fig. 24 DRIP - Horizontally laid panels

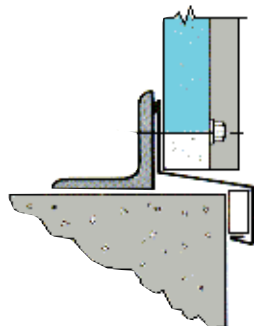

Fig. 25 DRIP - Vertically laid panels

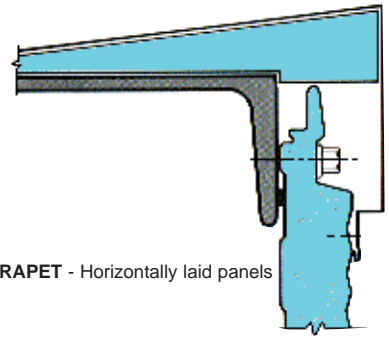

Fig. 26 PARAPET - Horizontally laid panels

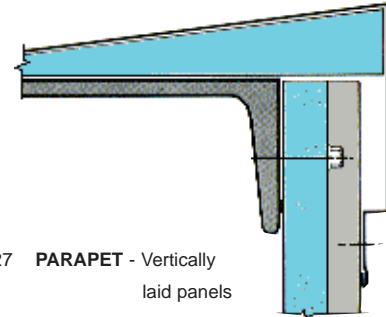

Fig. 27 PARAPET - Vertically laid panels

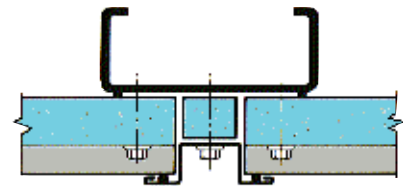

Fig. 28 VERTICAL JOINT - Horizontally laid panels

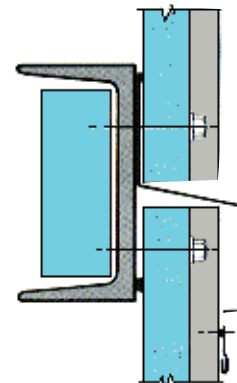

Fig. 29 HORIZONTAL JOINT - Vertically laid panels

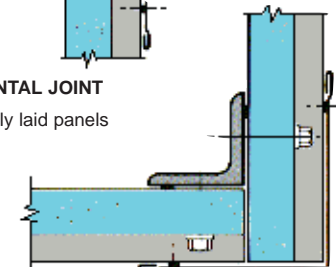

Fig. 30 CORNER - Horizontally laid panels

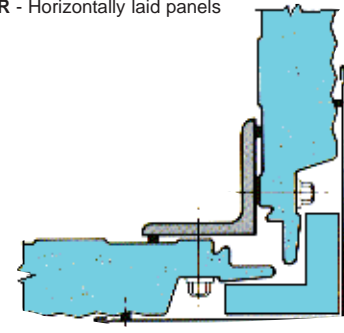

Fig. 31 CORNER - Vertically laid panels



8.0 Windows

To achieve the optimum appearance and strength it is important that the supporting structure is erected to the correct tolerance recommended for each panel type. Typically the tolerance between the flanges of adjacent rails will be rail spacing/600. This is particularly important for 'flat' panels because light reflections from the panel surface can exaggerate any variations in the panels and steelwork and create appearance problems.

Flatness tolerance should be agreed between the manufacturer and customer at the beginning of the contract.

7.8 Structural performance

7.8.1 Loads

Wall panels are generally only subject to wind pressures and suction loads. However, the possibility of impact loads should also be considered.

On any project the structural engineer is responsible for defining and specifying wind loads and cladding support centres.

The engineer should be familiar with the building exposure, shape and other factors. He should use CP3 Chapter 5 Part 2 and its amendments, and other authoritative information to establish local and general wind pressures.

7.8.2 Load span tables

Manufacturers provide load/span tables to enable the building designer to select the appropriate cladding and supporting steelwork centres. These should be based on the ECCS Recommendations, taking the effects of varying internal and external temperatures into account.

Typically spans of up to 3000 metres can be accommodated but where areas of high local suction load occur, spans may be governed by the strength of the panel fixing arrangement. It may be necessary to introduce additional supporting steelwork in these areas.

7.9 Fire

The metal faces of composite panels have a Class O surface as defined in the Building Regulations by achieving satisfactory ratings in fire tests to BS476 Parts 6 and 7.

Where fire resistance is required composite panels can be used, if necessary using additional fire resistant layers as recommended by the manufacturer.

Almost all configurations of windows can be incorporated into composite wall panel systems. In the broadest sense, windows fall into three types (see figure 32).

- a) ribbon windows
- b) unit windows
- c) porthole windows

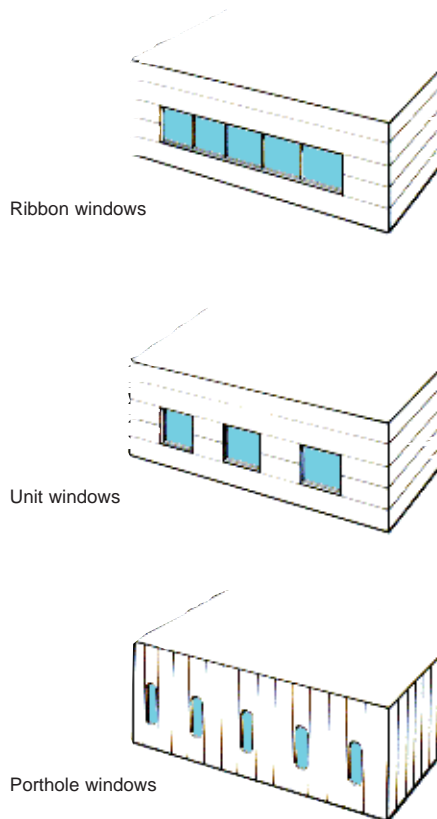

Fig. 32 TYPICAL WINDOW CONFIGURATIONS

Window frames are usually manufactured from aluminium or timber.

Both unit and ribbon windows require additional steel framing for support.

Wherever possible, panel/window junction details should allow the window to be installed after the panels have been fixed and also allow a damaged panel or window to be removed independently of one another.



Panels and windows are manufactured to fine tolerances and the appearance and performance of the highest quality products can be adversely affected by the incorrect sizing or alignment of window trimming steelwork. It is essential, therefore, that the steelwork trimming the windows is designed to prevent undue deflection due to self-weight or wind loads and that it is correctly aligned (see figures 33 - 35).

It is important that the window supplier and cladding contractor agree their responsibilities concerning design of the window installation.

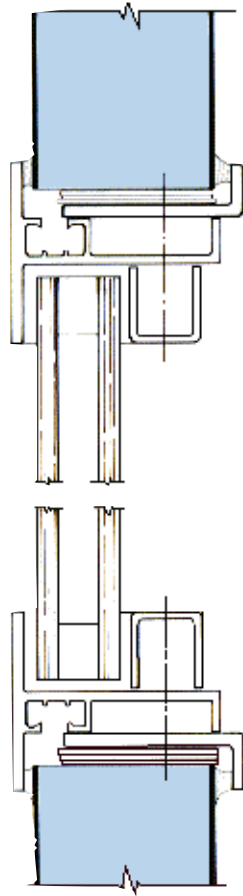

Fig. 33 PORTHOLE WINDOW

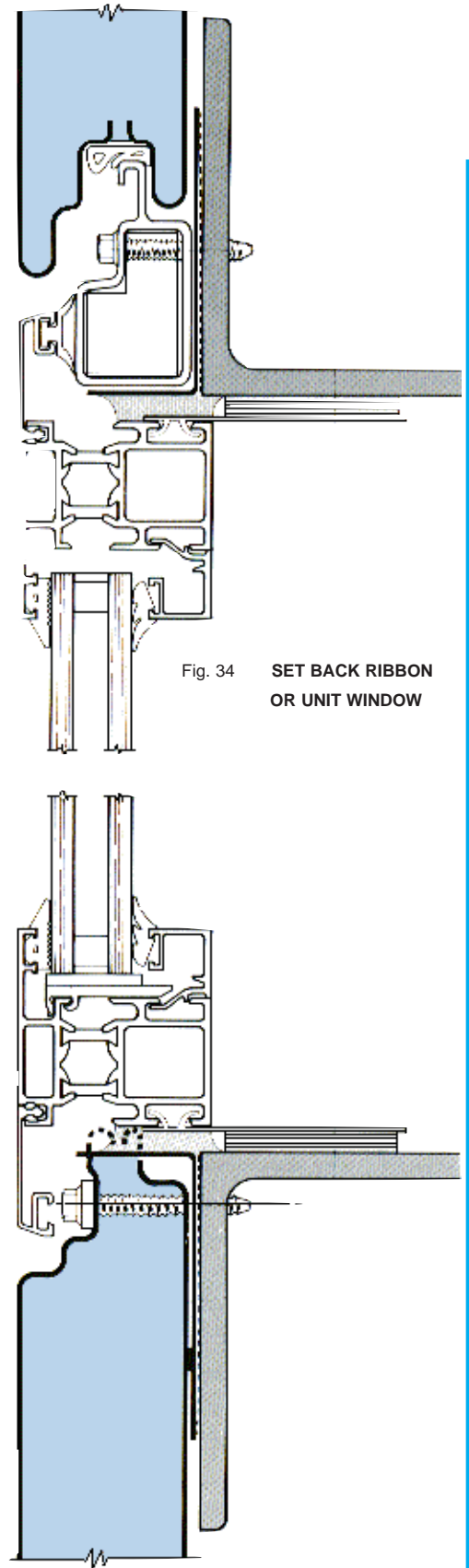

Fig. 34 SET BACK RIBBON OR UNIT WINDOW



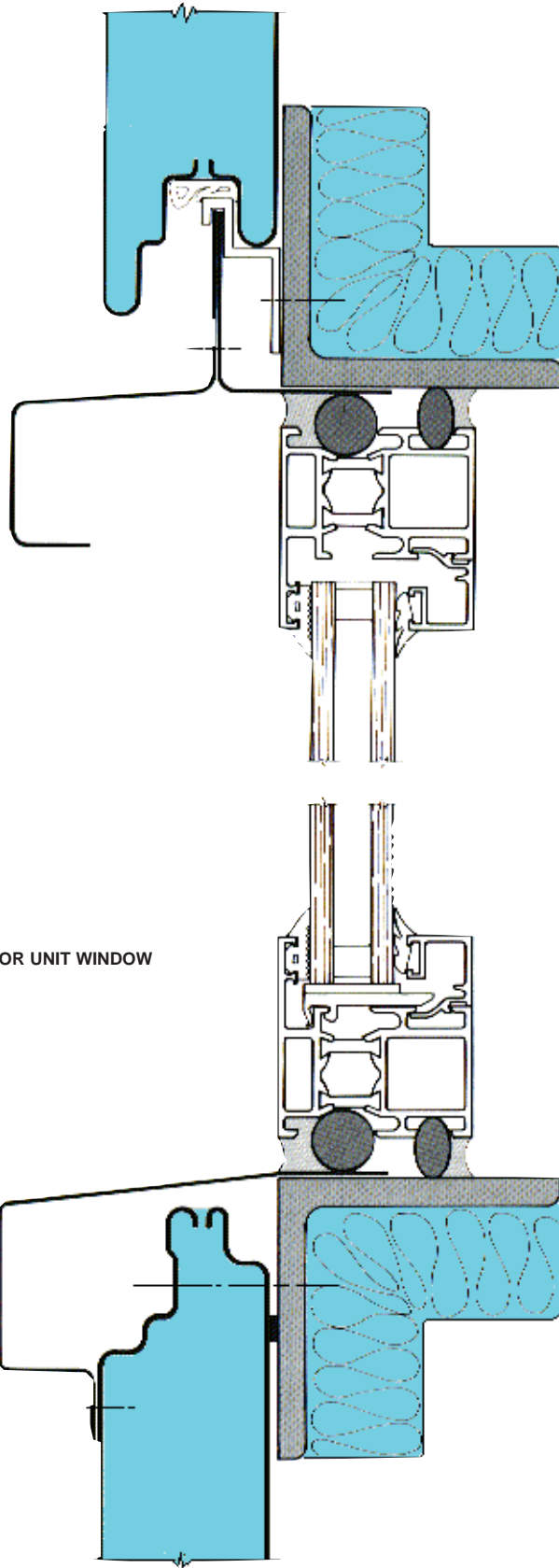

Fig. 35 FLUSH RIBBON OR UNIT WINDOW



9.0 Site Considerations

9.1 Site storage

Composite cladding panels are normally delivered to site from the factory in packs. These are typically 6 x 1 x 1m but may be as much as 30m long in some cases.

The packs should be carefully positioned and stored on site to prevent damage or deterioration and particular attention should be paid to the following points:

- a) Position away from vehicle and pedestrian routes
- b) Site on bearers on firm flat ground
- c) Cover and ventilate
- d) Ensure labelling is intact

9.2 Handling

Packs are normally removed from the delivery transport vehicle and stacked by crane (sometimes with a lifting beam) or by forklift, depending on the length and manufacturer's instructions. Roof panel packs may be lifted directly onto the roof and positioned at the rafters.

Individual panels may be man-handled or moved with lifting equipment, depending on application, particular panel design and length. Typically panels up to about 8m long can be man-handled. Note again however, that every care must be taken to protect the panels during erection so as to avoid damage.

Some panels are supplied with a protective plastic film on the weatherface to help prevent minor damage to the coating. This must be removed as soon as possible after the panel installation because if it is left in place for long periods the film will become very difficult to remove. Individual manufacturer's instructions should always be followed.

9.3 Health and safety

As in all building work good safety standards are essential to prevent accidents. In accordance with the Health and Safety at Work Act and the Construction Regulations a safe system of work should be planned before starting construction. If in doubt guidance can be obtained from the construction section of the local Health and Safety Executive.

In addition to the basic safe system of working the following specific precautions should be taken when using composite panels:

- 1 Take care when handling panels to avoid cuts from the edges of the sheets. Wear gloves to protect hands.
- 2 Take normal precautions when lifting heavy awkward objects to avoid lifting injuries in accordance with the Manual Handling Operations Regulations.
- 3 When necessary, panels should be cut with reciprocating saws (jig saws), not abrasive wheels. Goggles and dust masks should be worn to protect the operator from dust and metal cuttings.

Once fitted, the panels themselves create no health and safety problems in normal use.

9.4 Inspection and maintenance

Composite roof and wall cladding panels are designed and manufactured to give many years of reliable service. However, a regular inspection programme will further extend the life of the panel.

It is clearly wise on any building to design barriers etc. so that accidental damage is prevented as far as possible. However, in common with all cladding materials, composite panels are occasionally damaged while in place on the roof or wall of a building. Typically a vehicle might run into the wall while manoeuvring and dent or puncture the facing.

Some profiles can be overlaid with a single skin sheet but otherwise the replacement of an outer damaged section involves the removal of the entire panel and, depending on the panel type and building details, this could mean the removal of trims and perhaps other undamaged panels.

As with any other building material, the replacement sheet or panel may not be exactly the same colour shade as the original because of the natural tendency for colours to weather with time. Minor dents on roofs may be left unfilled if appearance is not a concern, provided the metal is not punctured. However, any damage to the coating on steel-faced panels must be carefully repaired and subsequently maintained to prevent premature corrosion. This is less likely to be acceptable on walls where appearance is more important.

Any areas of damage should be repaired in accordance with the manufacturer's maintenance manual.



- No 1 Recommended good practice for daylighting in metal clad buildings (Revised edition)
- No 2 Curved sheeting manual
- No 3 Secret fix roofing design guide
- No 4 Fire and external steel-clad walls: guidance notes to the revised Building Regulations 1992
- No 5 Metal wall cladding design guide
- No 6 Profiled metal roofing design guide (Revised edition)
- No 7 Fire design of steel sheet clad external walls for building: construction performance standards and design
- No 8 Acoustic design guide for metal roof and wall cladding
- No 9 Composite roof and wall cladding panel design guide
- No 10 Profiled metal cladding for roofs and walls: guidance notes on revised Building Regulations 1995 parts L & F
- No 11 Flashings for metal roof and wall cladding: design, detailing and installation guide

Leaflets:

Manufacturing tolerances for profiled metal roof and wall cladding

Built up metal roof and wall cladding systems tables of insulation

Latent defects insurance scheme: basic guide

Liability

Whilst the information contained in this publication is believed to be correct at the time of going to press, the Metal Cladding and Roofing Manufacturers Association Limited and member companies cannot be held responsible for any errors or inaccuracies and, in particular, the specification for any application must be checked with the individual manufacturer concerned for a given installation.

The diagrams of typical constructions in this publication are for illustration only.



THE METAL CLADDING & ROOFING MANUFACTURERS ASSOCIATION

18 MERE FARM ROAD
NOCTORUM
BIRKENHEAD
MERSEYSIDE
L43 9TT

TELEPHONE: 0151-652 3846
FACSIMILE: 0151-653 4080