

---

# FASTENERS FOR METAL ROOF AND WALL CLADDING: DESIGN , DETAILING AND INSTALLATION GUIDE

---

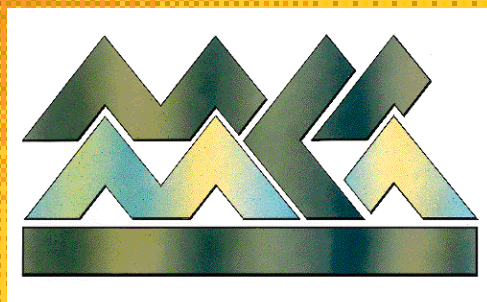

**THE METAL CLADDING & ROOFING MANUFACTURERS ASSOCIATION**

## CONTENTS

	Page
1.0 Introduction	1
2.0 Definitions	1
3.0 Fastener types	2
3.1 Primary	2
3.2 Secondary	2
3.3 Self drilling	2
3.4 Self tapping	3
3.5 Other fastener types	3
4.0 Performance criteria	4
4.1 Durability – Materials, coatings	4
4.2 Weathertightness – Washers	6
4.3 Aesthetics – Headforms, colouring	7
4.4 Structural – Technical performance	8
5.0 Typical cladding systems	10
5.1 Single skin	10
5.2 Built-up liner panel system	11
5.3 Composite panel and board systems	12
5.4 Secret fix systems	13
5.5 Built-up constructions on structural metal decks	13
5.6 Structural liner tray systems	14
5.7 Rooflights systems	15
6.0 Detailing	17
6.1 Fastener effective thread lengths	17
6.2 Fastener frequencies	17
6.3 Lap configuration	17
6.4 Thermal movement	18
6.5 Thermal bridging	18
6.6 Flashings	18
6.7 Corrugated profiles	19
6.8 Fixing to timber	19
6.9 Firewalls	19
6.10 Material compatibility	19
6.11 Swimming pools	20
6.12 Fastener penetrations	20
7.0 References	20

# Introduction

All roofing and cladding systems adopting profiled metal as the external surface, usually steel or aluminium, rely upon mechanical fasteners to secure the system to the structure. The importance of the correct selection of such fasteners is often underestimated by architects, designers, system suppliers and contractors and therefore this technical paper seeks to give guidance on the selection of appropriate fasteners designed for use within the popular metal roofing and cladding systems selected by the UK market for modern industrial and commercial buildings.

Although rainscreens, curtain walling and stressed skin design structures often incorporate fasteners similar to those within this technical paper, these types of systems have not been included and therefore advice from either the system supplier or a reputable specialist fastener manufacturer should be sought.

The guidance in this document is generally consistent with that given within BS5427:Part 1:1996, *Code of practice for the use of profiled roof and wall cladding on buildings*, MCRMA technical guides and relevant NFRC (National Federation of Roofing Contractors) publications.

*BS 1494:Part 1:1964, Specification for fixing accessories for building purposes.* Fixings for sheet, roof, and wall coverings has not been updated since its publication in 1964 and does not reflect the advances that have been made within metal cladding systems and fastener technology and therefore the Standard has very little practical use in today's market.

# Definitions

## 2.1 Fixing

A system of connection between two or more components.

## 2.2 Fastener

The mechanical connecting device used for the fixing.

## 2.3 Primary fixing

A fixing that secures the profiled sheeting or lining to the supporting structure e.g. sheeting to purlin or spacer, spacer to purlin.

## 2.4 Secondary fixing

A fixing that secures the laps of profile sheets to each other but not to the supporting structure; and also used to attach lightweight flashings.

## 2.5 Cladding

For the purposes of this paper, cladding refers to a roof or wall covering comprising of metal profiled sheeting. The cladding may be either an uninsulated sheet or an insulated system. Insulated cladding systems may be either factory formed composite panels or site assembled.



# Fastener types

## 3.1 Primary fasteners

Primary fasteners are used to transfer all the loads; design, dead, imposed and wind; acting on the cladding system back to the supporting structure and are therefore relied upon for their structural performance. The “supporting structure” is not solely limited to the main structural steelwork i.e. column, beam, rail and purlin, and would also include the spacer system and the structural liner/deck, where applicable.

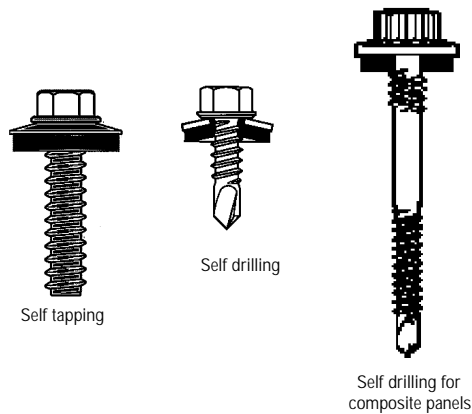

Fig 1: Examples of primary fasteners

Where the primary fasteners are exposed they have to provide a weathertight seal under all these load conditions including repetitive dynamic movement of the sheet. Additionally, where primary fasteners are exposed, they are normally required to be coloured to match (or even contrast!) the material they are securing.

For metal cladding systems, primary fasteners are usually threaded and contractors often prefer to use the “self-drilling” type due to their speed of single operation installation. The alternative to self-drillers are “self tappers” which require a pre-drill operation prior to installing the fastener.

## 3.2 Secondary fasteners

Unlike primary fasteners, secondary fasteners are not generally relied upon for structural performance however, they must be capable of providing a secure fixing. In certain applications, for example where secondary fasteners are used to provide lateral restraint or where they are part of a stress skin design, secondary fasteners are required to transfer loads and their strength would have to be considered in the structural calculations.

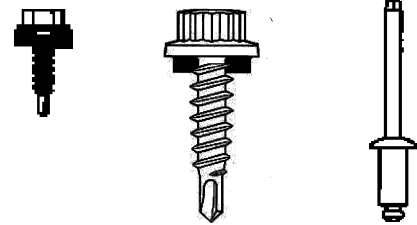

Fig 2: Examples of secondary fasteners

For metal cladding systems, secondary fasteners are typically used for sheet sidelap stitching and the securing of flashings and ancillary components to the sheeting. In order to provide a high degree of clamping to both compress any sealant and to draw the joint tightly together without thread stripping, stitching fasteners (stitchers) must be purpose-designed. Where secondary fasteners are exposed they may also need to provide a weathertight seal and colour matching. Secondary fasteners may often be of the self-drilling or self-tapping threaded type, but rivet type products are also frequently used.

## 3.3 Self-drilling fasteners

Self-drilling fasteners require no pre-drill operation and are therefore often preferred by the contractor/installer. They self-drill, threadform, and are set as a single continuous operation with a single purpose-designed screwgun that should have a free running speed between 2000 and 2600rpm and be fitted with correctly set depth locators or torque control devices.

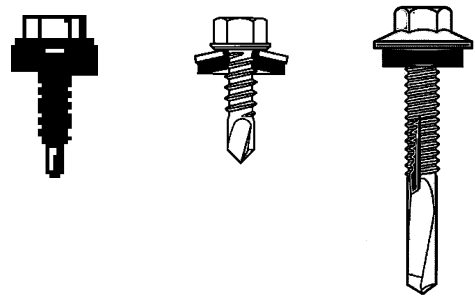

Fig 3: Examples of drillpoints on self drilling fasteners

Self-drilling fasteners are available with a range of point configurations designed for specific drilling capacities and manufacturers advise the minimum recommended thickness as well as the maximum capacity for each type, for example 1.2 to 3mm. The maximum drilling capacity of self drilling fasteners is typically 12mm. Where the component to be drilled into, usually the structural purlin/rail/or frame, exceeds the maximum



drilling capacity of the fastener, then a pre-drill operation would be necessary prior to installing the fastener (self-tapper, section 3.4 below).

Self-drilling primary fasteners typically have a minimum thread diameter of 5.5mm and secondary fasteners a minimum diameter of 4.8mm. The thread pitch may also vary between fasteners for different substrate thicknesses, for example some manufacturers adopt a fine (close) thread configuration for self-drillers into hot rolled steel and a coarser pitch for thinner cold-rolled sections.

### 3.4 Self-tapping fasteners

Self-tapping fasteners have no drillpoint and therefore a pre-drill operation is necessary. The contractor/installer requires two tools and two separate operations to install each fastener, thus making them significantly slower than self-drillers. When using self-tappers it is important that the correct pilot-hole size is drilled in order that optimum pullout performance is achieved. This requires careful selection of the drill diameter.

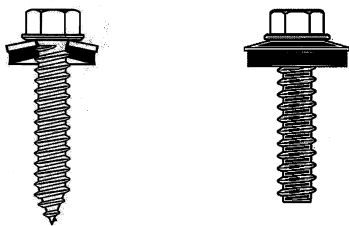

Fig 4: Examples of self tapping fasteners

The use of worn drill bits should be avoided. Oversize holes reduce pullout performance and undersize holes may prevent the fastener from being installed and subject the fastener to undue torsional stresses.

Self-tapping primary fasteners typically have a thread diameter of 6.3mm. There are different thread and lead-in configurations available specific to the fastener material and the material into which the fastener has to threadform, ie cold or hot rolled steel, timber or masonry.

Unlike self-drillers, self-tappers are not limited to 12mm substrate thickness. However, installation testing is advisable above this thickness. As with self-drillers, there are purpose-designed screwguns for self-tappers and the speed should be adjusted to a maximum of 600rpm.

### 3.5 Other fastener types

Self-drilling and self-tapping fasteners referred to in sections 3.3 and 3.4 above are normally of the threaded type, and, whilst these are the most widely used type, many other types of fastener are available for specific primary and secondary applications within the metal cladding market. These include:

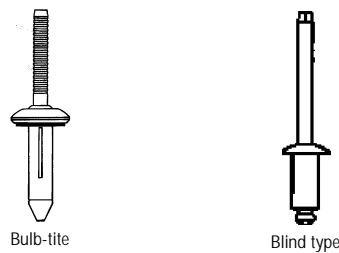

Fig 5: Rivet type fasteners

#### a) Rivet type fasteners

These are most widely used for secondary fixing, typically for connection to thin materials such as sidelaps on profiled sheeting and for flashings (section 6.6).

Certain types of rivets may be used for primary fixing, for example for fixing spacing sections to “thin” structural liners/decks on a built-up construction (section 5.5) where conventional threaded fasteners present an overdriving risk.

As with self-tapping threaded fasteners, rivets need to be applied through correctly sized predrilled pilot-holes. Rivets are available in a number of materials and can normally be supplied with sealing washers and colour caps where required.

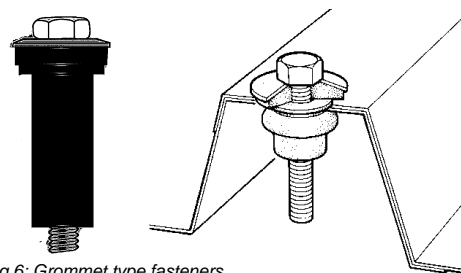

Fig 6: Grommet type fasteners

#### b) Grommet type fasteners

When connecting profiled sheet sidelaps to a grp or pvc rooflight material, (see section 5.7) a two part grommet type secondary fastener is usually recommended. A central threaded setpin is assembled into an elastomeric sleeve (usually EPDM or neoprene for special applications) which has a nut encapsulated at its lower end.



## Performance criteria

The assembly is inserted into a correctly sized pre-drilled pilot hole. Upon tightening, the nut draws the flexible sleeve up the fastener shank thus compressing and cushioning the sleeve around the materials being connected.

### c) Friction type anchors

As an alternative to threaded fasteners for fixing into concrete/masonry, one-piece non-threaded fasteners may be considered which rely on friction between the fastener and the substrate to provide the required degree of performance, usually in terms of pullout. This type of fastener relies upon the density and condition of the substrate and, normally, pilot holes within a tight diameter tolerance are necessary and advice should be sought from the fastener supplier with regards to suitability and performance. It is advisable to carry out site pullout tests when fixing primary fasteners into concrete or masonry.

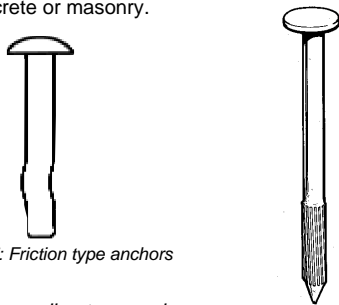

Fig 7: Friction type anchors

### d) Expanding type anchors

These provide a further method of fixing cladding components back to a concrete type substrate. This type of fastener is usually two-part with an outer sleeve, typically metallic or plastic, which expands when the internal part of the fastener is "installed". Pre-drilled holes are usually required and the expansion of the installed product either displaces/undercuts the substrate or produces high levels of friction against the substrate wall to provide the performance. A wide range of products is available with different performance levels within substrates over a broad range of densities, therefore advice should also be sought from the supplier on product selection and performance.

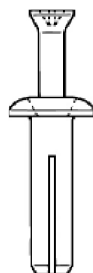

Fig 8: Expanding type anchors

BS 5427:Part1:1996, *The use of profiled sheet for roof and wall cladding on buildings*, the MCRMA technical design guides and other industry publications such as the NFRC Blue Book give extensive detailed references for the design and performance requirements of metal cladding systems. Fasteners are vital to all these systems and provide a specific range of functions which should all be considered in order to make an appropriate selection.

The functions of fasteners may be split into four sections:

- DURABILITY
- WEATHERTIGHTNESS
- AESTHETICS
- STRUCTURAL

This section will address these in **general** terms, and where the fastener performance is specific to the type of roofing system, this will be dealt with in more detail under the relevant part of section 5.

### 4.1 Durability

A fastener must have a level of durability compatible to the intended functional lifespan required of the selected cladding system in the particular application. Fasteners are available in a number of materials all of which offer different levels of corrosion resistance/durability when exposed to a variety of conditions, both external and internal.

BS 7543 *Guide to durability of buildings and building elements, products and components* gives some guidance on design life requirements of buildings and components within the construction and BS 5427 gives guidance on both external and internal environmental considerations.

Threaded self-tapping and self-drilling fasteners are available in a range of materials; carbon steel, stainless steel and aluminium.

**Refer to MCRMA technical paper No 10: Profiled metal cladding for roofs and walls: guidance notes on revised Building Regulations 1995 parts L & F**

#### 4.1.1 Carbon steel threaded fasteners

Unprotected carbon steel will corrode when exposed to the atmosphere. The rate of corrosion may be rapid and depends upon the environmental conditions. Carbon



steel fasteners for metal cladding are therefore surface coated to extend the durability of the product. The surface coating generally available for such fasteners may be zinc and/or organic or polymeric. It must be recognised that, as part of a metal cladding system, these surface coatings will inevitably receive damage during installation through metal components, for example the profiled sheet and the spacer system or purlin/rail, which will reduce their durability in certain applications.

By reference to Table 2 of BS 7543 fasteners should not be classed as either 'replaceable' or 'maintainable' but should be lifelong to the service life of the material or system with which they are used.

Coated carbon steel fasteners have been shown to be suitable for many roofing and cladding applications where there is not the risk of corrosive internal and external environments and where the service life required of the fastener and cladding system does not exceed approximately 25 years. External/exposed carbon steel fastener heads should be protected from low corrosion-risk external environments by factory 'colouring' or integral plastic heads to provide this service life (see section 4.3).

Carbon steel fasteners should **not** be used with aluminium (or stainless steel) profiled sheeting unless the fasteners are internal and the internal conditions are limited to Grade A-normal humidity as defined in MCRMA technical paper No 10.

Table 1: Guide to selection of exposed fastener material

Fastener Materials	Environment		Life expectancy (years) (see note 3)	Sheet Material (see Note 1)			
	Internal humidity grade	External exposure		Aluminium	Coated steel	Stainless steel	GRP/PVC fibre cement
Minimum washer dia				19mm	15mm	15mm	29mm
Coated carbon steel and push-on plastic caps	dry/low humidity 'A' and 'B'	Urban/Rural	10/20	NR ✗	✓	✗	✓
		Industrial*	10/15	NR ✗	C	✗	✓
		Coastal/Marine	10	✗	C	✗	C
	high humidity 'C'	Urban/Rural	10/15	NR ✗	C	✗	C
		Industrial*	10	NR ✗	C	✗	C
		Coastal/Marine		✗	✗	✗	✗
Coated carbon steel with integral plastic coloured head	dry/low humidity 'A' and 'B'	Urban/Rural	15/25	NR ✗	✓	✗	✓
		Industrial*	15/25	NR ✗	✓	✗	✓
		Coastal/Marine	10/15	NR ✗	C	✗	C
	high humidity 'C'	Urban/Rural	10/15	NR ✗	✓	✗	✓
		Industrial*	10	NR ✗	C	✗	C
		Coastal/Marine	10	✗	C	✗	C
Austenitic stainless steel	all humidity grades	Urban/Rural	25+	✓	✓	✓	✓
		Industrial*	25+	✓	✓	✓	✓
		Coastal/Marine	20	✓	✓	✓	✓
Aluminium secondary fasteners e.g. rivets	all humidity grades	Urban/Rural	20/25	✓	✓	✗	C
		Industrial*	15/20	✓	✓	✗	C
		Coastal/Marine	15/20	C	C	✗	C

KEY:

✓ recommended for use in these environments

✗ unsuitable for use in these conditions

C check suitability of both sheet system and fastener with manufacturer

NR not recommended for use with aluminium sheets by some profile manufacturers

\* subject to non polluted environment, may not be suitable in corrosive or other chemical laden conditions

Note 1 This table gives guidance on the selection and functional life **of the fastener** in various sheet materials. Consult the sheet manufacturer, regarding the most appropriate sheet material and coating and its functional life in the particular environment.

Note 2 For carbon steel fasteners which are **not exposed** to the external environment, the functional life would be similar to those tabled above for carbon steel with integral colour heads.

Note 3 The above periods are for the fasteners' **functional life expectancy**. Where a warranty is required then this may be typically up to 10 years for carbon steel and up to 25 years for stainless steel.



Table 1 (reproduced from the NFRC Blue Book) may be referred to for guidance on the anticipated service life expectancies of coated carbon steel fasteners in differing external and internal environments.

#### 4.1.2 Stainless steel threaded fasteners

Stainless steel is a generic term and there are over 200 grades. Not all grades are suitable for metal cladding fasteners. Of the grades recommended in BS 5427 for stainless steel roofing and cladding fasteners, 304 is the typical grade used and this would be considered suitable for the majority of applications. Other grades are also used. The designer should ensure the suitability of the fastener specification for the particular application/construction. The fastener manufacturers will provide performance data for their products.

Appropriate grades of stainless steel fasteners can provide enhanced durability and corrosion resistance over coated carbon steel fasteners as referred to in section 4.1.1 above and could therefore provide a service life exceeding 25 years even in aggressive external conditions and internal Grade C conditions - high humidity or special environments (MCRMA technical paper No 10). However, in these conditions the manufacturer should always be consulted to determine the most suitable fastener (see section 6.11). To enable stainless steel fasteners to self-drill into steel supports, the fasteners may have a heat-treated and hardened carbon steel drillpoint. The design and selection must ensure that, when installed, all threads within and above the support are stainless and not carbon steel.

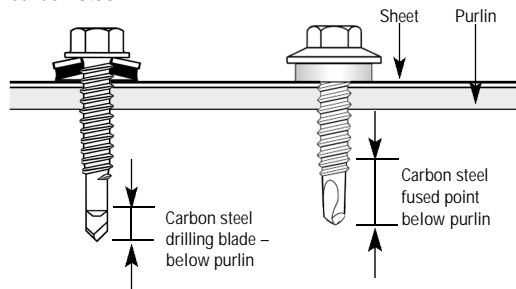

Fig 9: Stainless steel self drillers – all threads within and above purlin must be stainless

#### 4.1.3 Aluminium threaded fasteners

Aluminium is regarded as a highly durable material, exceeding the durability of coated carbon steel but not matching the corrosion-resistance of stainless steel. However, the applications within metal cladding for which aluminium threaded fasteners can be considered are restricted due to the softness of the material. Aluminium threadforming fasteners may be considered as primary fasteners for securing only aluminium and certain 'plastic' cladding profiles to timber supports and as secondary fasteners within aluminium profiles. Aluminium threadforming fasteners cannot be used in conjunction with steel purlins, spacers or cladding as the aluminium does not have sufficient hardness to drill or threadform into steel.

#### 4.2 Weathertightness

Normally this weathertightness requirement of fasteners relates only to exposed external fasteners. However, the ability of a fastener to maintain a seal is often required on certain internal fasteners where the restriction of air and vapour diffusing into the system is desirable.

The ability of a fastener to re-seal holes made in the cladding profile depends primarily on the design and performance of a compressible sealing element. The sealing element must be resilient to the mechanical forces to which it is subjected during installation of the fastener as well as the environmental and mechanical conditions encountered during its service life.

It is generally recognised that EPDM (ethylene-propylene-diene-monomer) provides the best all-round performance for the sealing element. It has the ability to maintain its elasticity under all conditions including temperature extremes, moisture, UV light, ozone and both general atmospheric and aggressive industrial pollutants. The thickness and hardness of the sealing material should be designed specifically for the fastener application to ensure adequate sealing.





To ensure the sealing element is held in place and prevented from excessive 'extrusion' away from the fastener shank during installation, the EPDM may be bonded or vulcanised to a metal backing washer. This metal washer should have a corrosion resistance compatible with the fastener material and should be of sufficient metal thickness and shape to resist inversion/pullover loadings resulting from wind suction, angular driving and typical site installation practices (refer to section 4.4.4).

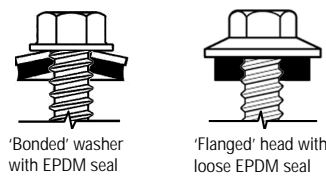

Fig 10: Washer types

Some manufacturers/suppliers offer a separate EPDM seal and a flanged head to the fastener. This provides excellent inversion/pullover resistance. The underside of the head must be purpose-designed to retain and control the extrusion of the EPDM seal under all conditions.

The diameter of the washer/sealing elements available range typically from 10mm to 32mm. The selection relates to the sheet material and degree of exposure ie roof or wall, and whether the fastener is used in a primary or secondary application.

As a guide the following minimum diameters can be used but reference should be made to section 5.0 where more specific guidance is given.

Table 2

Material	Roof	Wall
GRP/PVC primary fasteners	29-32mm	29-32mm
Aluminium sheet primary fasteners	19mm	15mm
Steel sheet primary fasteners	15mm	15mm
Secondary stitching fasteners	10mm	10mm

### 4.3 Aesthetics

This functional requirement of fasteners relates only to those which are visible once installed.

The industry standard headform for a self-drilling/ self-tapping non-coloured fastener is an 8mm (5/16") hexagon, measured across flats, typically 4-5mm deep. Below the hexagonal portion there would be either the bonded washer or the flange as referred to in section 4.2 above.

Through-fixed profiled metal cladding within the industrial sector is predominantly colour-coated, other than relatively low volumes of mill-finish or stucco-embossed aluminium, plain galvanised steel and plain zinc/aluminium coated steel.

The original method used by the contractor to colour match "standard" fastener headforms was to site-apply a push-fit plastic cap. Whilst this method may have been economic in terms of components, it proved to be labour intensive for the contractor and, in many cases, an unsuccessful colour match for the client in terms of long term stability and durability. Push-fit caps can easily be picked off; they rarely have equal levels of colour fastness offered by colour coated metals; they are prone to UV degradation; and they can, if not suitably designed or installed, entrap moisture which could accelerate corrosion of a carbon steel headed fastener leading to unsightly rust stains down the cladding. For the contractor, applying push-fit caps is another operation which could be avoided. Missing or dislodged caps are a common item on many snagging lists and the access and labour required to replace them adds disproportionately to the contractor's costs.

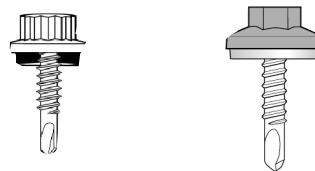

Fig 11: Factory coloured integral heads

There has been a significant trend away from push-fit caps to factory coloured 'integral' heads. This headform usually involves moulding a coloured plastic/nylon around the head of the fastener. Some manufacturers mould around their standard hexagonal headform which may or may not be flanged, and some mould around a special non-hexagonal headform. The finished moulded headform may either be hexagonal or bi-hexagonal. Whichever method is selected, the design should not result in long term permanent loads being transmitted by the compressed sealing element directly onto the plastic/nylon as this may lead to premature head detachment. The load should always be transmitted back through the sealing element to the metal portion of the fastener head.



As an alternative to moulded heads as described above, fasteners are available with lower profile headforms for applications where the client wishes the fastener heads to be as unobtrusive as possible. This requirement is normally associated with walling applications and, in particular, with sidelap stitchers and flashing details. These fasteners may be colour matched by means of factory applied 'painting', usually a resilient and colour-stable powder coating. Frequently these self-drilling low profile colour-headed fasteners are chosen as an alternative to rivets and push-on caps due to their speed of installation as well as the preference for factory coloured heads as referred to above.



Fig 12: Low profile head

Even though these factory coloured headforms give added corrosion resistance to the exposed head portion of the fastener, BS 5427 states that *"this should not be relied upon as the sole basic protection against corrosion"*. As referred to in sections 4.1.1 and 4.1.2 above, the corrosion resistance/durability of the fastener is attributed to the fastener material.

It is extremely important that the correct socket is selected appropriate to the particular fastener headform. Furthermore, to avoid damage to the fastener head, to the washer and, not least, to the connection in the supporting material/structure, it is equally important that **screwguns are fitted with correctly set depth-locators or torque-control devices.**

#### 4.4 Structural

In addition to satisfying the durability, weathertightness and aesthetic functional requirements, the fastener also has to be capable of withstanding a wide range of types of loading. Some types of loading apply to virtually all metal cladding fasteners regardless of their application, whereas some loadings are specific to the system in which the fastener is incorporated.

The loadings which apply to most fasteners include:

- Tensile loads pullout resistance
- Tensile loads pullover resistance
- Shear loads shear force resistance
- Installation loads overdrive resistance

Loadings which tend to be specific to the cladding system include:

- Bend resistance composite panel fasteners
- Pushdown resistance composite panel fasteners
- Clamping stitching fasteners

This group of structural performance requirements is dealt with under the relevant part of section 5 of this publication.

##### 4.4.1 Pullout resistance

This is the ability of a fastener's connection within its supporting material to remain intact and resist the axial and tensile loadings. **As the UK metal cladding market frequently involves primary fixing into relatively thin cold rolled purlins, rails and spacing systems, pullout of primary fasteners is often the most critical of the loadings that should be considered.**

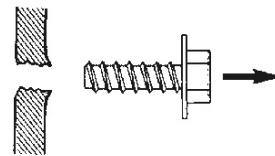

Fig 13: Pullout resistance

Rivet type fasteners resist these loadings by expanding on the underside of the supporting material however, it should be recognised that with certain types of rivet, particularly those manufactured from aluminium, the rivet body may fail in tension before it pulls out of the support. Advice and documentation should be obtained from the supplier.

With threaded fasteners, the ability to resist pullout/tensile loadings relates to the combination of thread diameter, drillpoint diameter and support material thickness and grade. As a general rule, the drillpoint diameter, or pre-drill in the case of self-tappers, reduces relative to the thread diameter as the support material reduces in thickness. As noted in section 3.3, self-drilling fasteners for metal cladding systems have drillpoints purpose-designed for the thickness of the support they drill through. Thus, providing the contractor



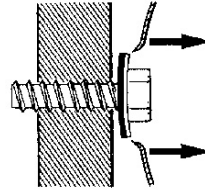

Fig 14: Pullover resistance

selects the correct product for the application he will achieve optimum pullout performance **providing the fastener is installed correctly using screwguns fitted with depth locator or torque control devices.**

Where self-tapping fasteners are selected, the contractor must ensure he uses a drillbit that is in good condition and of a diameter recommended by the fastener supplier appropriate for the support thickness. Failure to follow this guideline will result in reduced pullout values if the hole is too large, or installation problems if the hole is too small (refer to section 3.4).

BS5427:Part1:1996 gives some typical methods for testing the pullout strength of fasteners and there are various other internationally recognised and accepted industry tests adopted by manufacturers. This means that similar fasteners, which are designed for the same purpose, from different manufacturers may have quite different published pull out strengths because of their design and the different test methods used. Furthermore the test methods do not necessarily reproduce the realistic application of the fastener in a particular metal cladding system (and its supports), so **the fastener manufacturers' published pull out values should be treated with caution.**

Manufacturers and suppliers of fasteners should have available their products' typical ultimate failure values, together with their standard deviation (based on their own particular test). The contractor or designer should also obtain advice from his cladding system suppliers to ensure the proposed fastener type and frequency can accommodate all design loadings, using the appropriate safety factors detailed in Annex B of BS 5427.

#### 4.4.2 Pullover resistance

This is the ability of the fastener to prevent the sheet material failing by pulling over the head of the fastener. As stated in section 4.4.1, this is rarely an issue in today's metal cladding market however, pullover resistance of fasteners should always be considered particularly within applications incorporating steel profiles typically less than 0.7mm thickness, aluminium profiles, GRP/PVC profiles, and applications including support structures thicker than 1.5mm, as pullover failure may occur at a lower value than pullout failure.

The principal resistance of any fastener to pullover is provided by the headform/washer combination. Section 4.2. illustrated how the headform and washer design can ensure weathertightness. The pullover forces have to be resisted by the metal backing of the bonded washer or the flanged head. Bonded washers are available in a range of diameters from 10mm up to 32mm, and where the pullover risk increases then it would be normal practice to increase the washer diameter. Flanges are typically restricted to 15mm diameter and therefore, with some sheet materials and loading conditions, it may be necessary to incorporate an additional bonded washer of increased diameter under the flanged head. The contractor/designer must ensure that the washers are of sufficient metal thickness and shape to resist the loads.

As with pullout, there are industry tests available, including those described within BS 5427 and cladding suppliers should publish or have values available.

#### 4.4.3 Shear force resistance

Fasteners within metal roofing systems are not generally subjected to levels of shear forces that will adversely affect their performance. In applications where fasteners are connecting structural components of typically 1.5mm minimum thickness, designers may refer to suppliers' ultimate shear values and apply the appropriate safety factor. Where fasteners are connecting a thinner material to another component for example, a profiled metal sheet to a purlin, rail or spacer, the shear loads transmitted through to the fastener would normally be accommodated within the flexibility of the system or, at worst, may result in elongation of the hole in the thinner material.

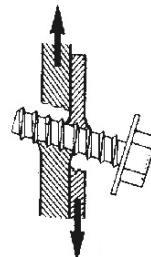

Fig 15: Shear load resistance

Where the fastener is exposed this is accommodated by correct washer diameter selection.

As noted in the introduction, stressed skin design roof systems have not been included in this publication and therefore where fasteners are intended for use in such



# Typical cladding systems

shear load applications then reference should be made to either BS 5950: Part 9:1994 *Code of practice for stressed skin design*, or the system supplier for guidance on fastener selection and performance.

## 4.4.4 Installation loadings

Undoubtedly, one of the most aggressive loads to which fasteners for metal cladding systems are subjected are those loads applied during the installation process. Unfortunately it is all too common to see fasteners being overdriven/overtightened. Fastener performance, both in terms of pullout and pullover(washer inversion), will often be adversely affected as a result of overdriven fasteners and this may, in extreme cases, lead to catastrophic failure of the system or, at least, to water ingress or local detachment of part of the system.

The key to correct fastener installation and therefore achieving optimum performance lies in the selection and use of tooling. Most fastener suppliers also supply or recommend tooling with which their products may be installed. Tools must be maintained and both fastener and metal roofing system suppliers recommend that screwguns are fitted with correctly set depth locators or torque control devices.

In recognition of this common site-control problem, some fastener suppliers can provide tooling systems which, as well as often increasing the speed of installation, have attachments which can ensure correct and consistent fastener setting.

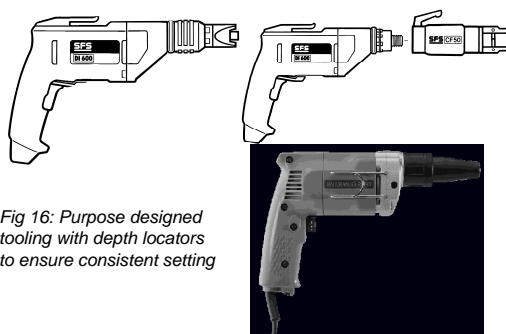

Fig 16: Purpose designed tooling with depth locators to ensure consistent setting

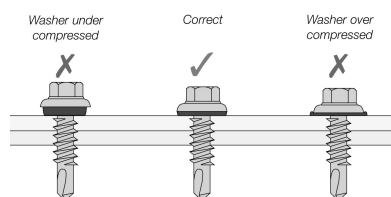

Fig 17: Correct installation for primary fasteners

This section takes each of the popular cladding systems selected by the UK market for modern industrial and commercial buildings and gives more specific guidance on the selection of fasteners in order that client expectations may be met. Unless specifically noted otherwise, the choice of fastener material is left for the designer/ system supplier/contractor to determine by making reference to section 4.1. Similarly, the fastener types referred to are generally self-drillers, other than the rivet/grommet type referred to in section 3.5.

## 5.1 Single skin metal cladding

### 5.1.1 Trapezoidal steel sheet, colour coated

Primary fasteners Preferred fastener location - valley  
5.5mm minimum thread diameter  
Factory coloured integral head  
15mm minimum washer diameter

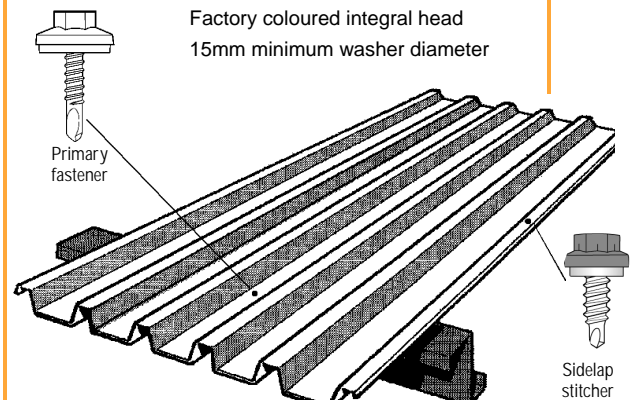

Fig 18: Single skin construction

Sidelap stitchers Crown position on roof  
If sidelap is on crown on wall, low profile head self-driller may be preferred  
Factory coloured integral head  
4.8mm minimum thread diameter  
Crown option on wall - rivet + cap  
10mm minimum washer diameter

Rooflights Where rooflights are included refer to section 5.7

### 5.1.2 Trapezoidal aluminium sheet, colour coated

Primary fasteners Stainless steel  
Preferred fastener location - valley  
5.5mm minimum thread diameter  
Factory coloured integral head  
19mm washer on roof, 15mm minimum on wall



Sidelap stitchers	Stainless steel or aluminium alloy Crown position on roof If sidelap is on crown on wall, low profile head self-driller may be preferred 5.5mm minimum thread diameter Factory coloured integral head Crown option on wall - rivet + cap 10mm minimum washers
Rooflights	Where rooflights are included refer to section 5.7

### 5.2 Built-up liner panel system

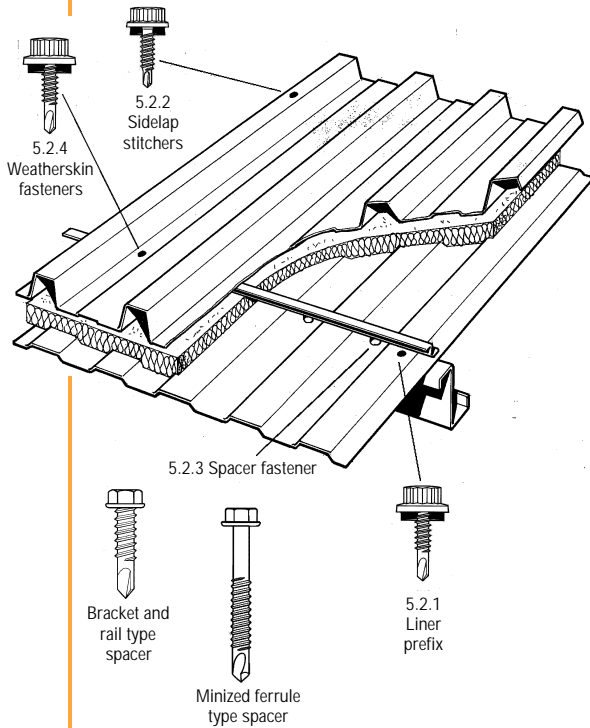

Fig 19: Built-up liner panel system

Refer to MCRMA technical paper No 5: Metal wall cladding design guide and MCRMA technical paper No 6: Profiled metal roofing design guide

#### 5.2.1 Liner prefix

There has been major debate within the metal cladding industry on the subject of health and safety and what is a fragile or non-fragile construction. This publication is not intended to give specific guidance on health and safety issues. However, tests commissioned by the MCRMA have shown that the fastener specification and frequency can play an important part in the impact resistance of the cladding system.

Primary fasteners	Standard hex head 15mm washer on roof 5.5mm minimum thread diameter on roof Optional washer on wall 4.8mm minimum thread diameter on wall
-------------------	---

#### 5.2.2 Liner sidelaps

On non-structural liners which are typically 0.4mm steel, it is not usually practical to mechanically sidelap stitch, particularly on roofing applications. Reinforced aluminium self-adhesive tape over the lap has proven more practical where there is the requirement for seals.

On firewalls it may be necessary to sidelap stitch the liner panel. This is normally done with steel, not aluminium, rivets. Please refer to the system supplier (refer to section 6.9).

Rooflights	Where rooflights are included refer to section 5.7
------------	--

#### 5.2.3 Spacer fastener

There are a number of spacer systems available in the UK metal cladding market.

Type one includes a continuous zed-shaped spacer bar which is fastened through spacer stools (ferrules), usually of a virgin plastic (polypropylene) material, or steel if used within a firewall system (refer to section 6.9). These ferrules are spaced in accordance with individual system suppliers' recommendations.

Type two includes a specially shaped spacer rail attached to brackets. Fasteners are installed through pre-punched holes in the foot of the bracket.

Spacer fastener	Hexagonal head 5.5mm minimum thread diameter No washer
-----------------	--

#### 5.2.4 Trapezoidal steel weatherskin sheet, colour coated, fixed to spacer section

Primary fasteners	Preferred fastener location - valley Factory coloured integral head 5.5mm minimum thread diameter 15mm minimum washer diameter Pilot point on wall if compressed insulant is over the spacer (see section 5.6)
-------------------	--



Note: Insulation should not be laid over spacers on roofs because of the risk of leakage if the strength of the compressed insulation reduces during the building life

Sidelap stitchers	Crown position on roof If sidelap is on crown on wall, low profile head self-driller may be preferred Factory coloured integral head 4.8mm minimum thread diameter Crown option on wall - rivet + cap 10mm minimum washer diameter
Rooflights	Where rooflights are included refer to section 5.7

Refer to MCRMA technical paper No 5: Metal wall cladding design guide; MCRMA technical paper No 6: Profiled metal roofing design guide and MCRMA technical paper No 9: Composite roof and wall cladding panel design guide

### 5.3 Composite panels and rigid board systems

Factory formed composite panels are available in a wide range of designs; ranging from traditionally through-fixed with exposed fasteners, concealed-fixed through a raised crown, fixed by means of clips and some, particularly flat and low-profile walling panels are fixed through the concealed joint. It is important, therefore, that the panel suppliers' recommendations are followed when selecting fasteners. The through-fixed panels and also those fixed through their raised crown share a common requirement of the fastener design.

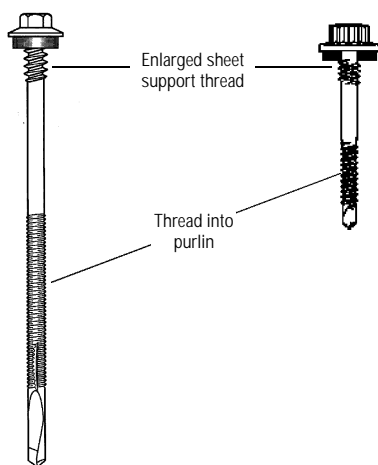

Fig 20: Dual threaded composite panel fasteners

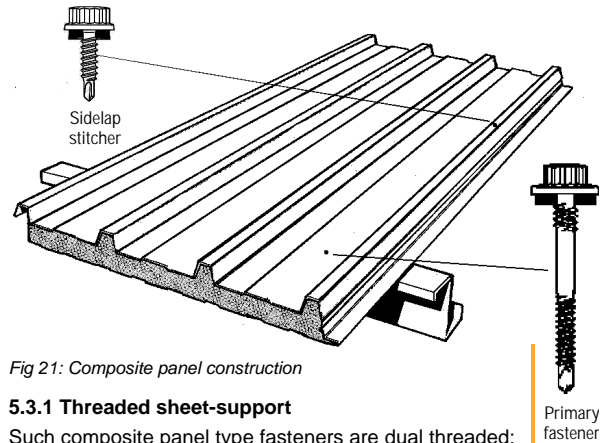

Fig 21: Composite panel construction

#### 5.3.1 Threaded sheet-support

Such composite panel type fasteners are dual threaded; the industry-standard 5.5mm (self-driller) or 6.3mm (self-tapper) lower thread fixes into the purlin or rail and a secondary thread of increased diameter is positioned below the head and washer. This upper thread is designed to provide support to the outer metal skin of the panel to ensure that the sealing element of the washer is under permanent compression. Some composite panel fasteners have a non-threaded section immediately below the head as a means of ensuring washer compression. Different fastener suppliers have different diameter top threads, those with the larger diameters will inevitably tend to offer more support to the outer skin of the panel. Although there is not, at present, a formal and universally specified test for the performance of this top thread, a test that may be adopted is defined in BS 5427:Part1:1996 in Annex A. This is a concentrated load test, or walkability test, which simulates the dynamic load, including a safety factor, of a person walking over the sheet. This top thread should withstand such a loading in order to achieve a permanent seal.

#### 5.3.2 Fastener flexibility

A structural load which is associated with fasteners designed for composite panels is a repetitive bending load transmitted to the head of the fastener as a result of panel deflections under wind loadings and general expansion/contraction effects of the panel. This results in the fastener being continually and repetitively bent around the pivot point in the purlin. The ECCS (European Convention for Constructional Steelwork), Document No.66 *Preliminary European Recommendations for Sandwich Panels, Part 1 Design*, defines the repeated bending tests to which composite panel fasteners must be subjected and suppliers should be able to provide guidance on the maximum allowable fastener deflection relative to the panel thickness.

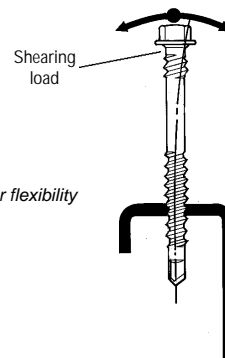

Fig 22: Fastener flexibility



### 5.3.3 Through-fixed steel faced trapezoidal composite panel, colour coated

Primary fasteners	Preferred fastener location - valley Factory coloured integral head 5.5mm minimum lower thread diameter Enlarged thread under head 19mm washer on roof, 15-16mm on wall
Sidelap stitchers	Crown position on roof If sidelap is on crown on wall, low profile head self-driller may be preferred Factory coloured integral head 4.8mm minimum thread diameter Crown option on wall - rivet + cap 10mm washers
Rooflights	Where rooflights are included refer to section 5.7

As noted above, composite panels have many different jointing and fixing designs, therefore reference must be made to the supplier to ensure appropriate and approved fasteners are selected.

## 5.4 Secret fix roofing systems

Refer to MCRMA technical paper No 3: Secret fix roofing design guide

Secret fix roof systems, within the scope of this section, are self-supporting metal profiles, usually either steel or aluminium, with virtually no visible through fixings. Such systems are variously expressed as concealed fixing, standing seam, clip fix, or raised seam. The profiled weathering sheet is usually secured to a clip or halter which is mechanically fixed to the supporting structure, either the purlin or a spacer section.

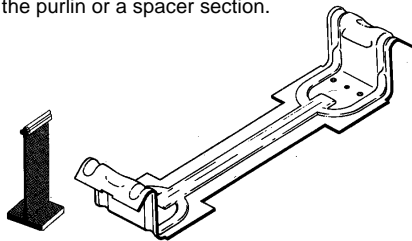

Fig 23: Extruded aluminium halter and steel or aluminium clip

Where the system is to be insulated, this is normally achieved with metal liners and insulation. These liners are prefixed to the structure in a similar manner to the equivalent elements of a built-up liner panel system with fasteners as described in sections 5.2.1, 5.2.2 and 5.2.3 above.

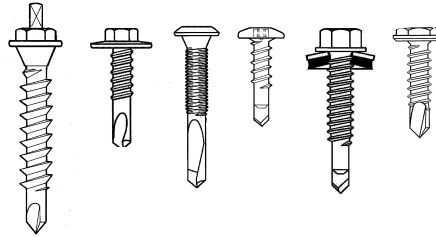

Fig 24: Specialist fastener design for secret roof fixing systems

A specialist/proprietary fastener is then used to secure the clip/halter. These fasteners provide a specific and vital function to the overall mechanical performance of the system and therefore should always be selected in accordance with the system supplier's recommendations. Some suppliers actually include this primary fastener within their package when supplying their roofing profiles and clips/halters.

The fastener material, headform, and thread diameter are usually purpose-selected for the particular system. Materials are normally coated carbon steel or stainless steel, headforms may be the standard hexagon, a flanged hexagon, or a low-profile. Thread diameters may vary from 4.8mm to 6.5mm depending on the required performance and fastener frequency.

## 5.5. Built-up constructions on structural metal decks

Section 5.2 described the typical built-up liner panel system which incorporates a non-structural metal liner. This type of liner does not normally form a safe-working platform. Where it is desirable to lay the roofing system off a safe-working platform this can be achieved by increasing the profile strength of the liner. This method is frequently adopted with the secret fix systems referred to in section 5.4 above. Fasteners to secure these more structural lining sheets through to the purlins would be the same as in sections 5.2.1, 5.2.2 and 5.2.3 above.

Structural metal decks offer the designer a further option. These may span between traditional purlins or they may span between the main structural beams, eliminating the need for purlins. The primary fasteners securing the deck to the beam would need to be self-tappers where the total flange and deck thickness exceed 12mm. Due to the long spans, the shear and pullover capacities of the fasteners and deck would need to be considered to determine the fastener frequency and washer/flange requirement.



Where structural decks are used rather than purlins, the spacing system may be fixed either directly to the deck or, alternatively, to an intermediate section, frequently a metal top-hat shaped profile, which is fixed directly to the deck. Where there is a particular acoustic requirement then acoustic layers may also be positioned within the construction.

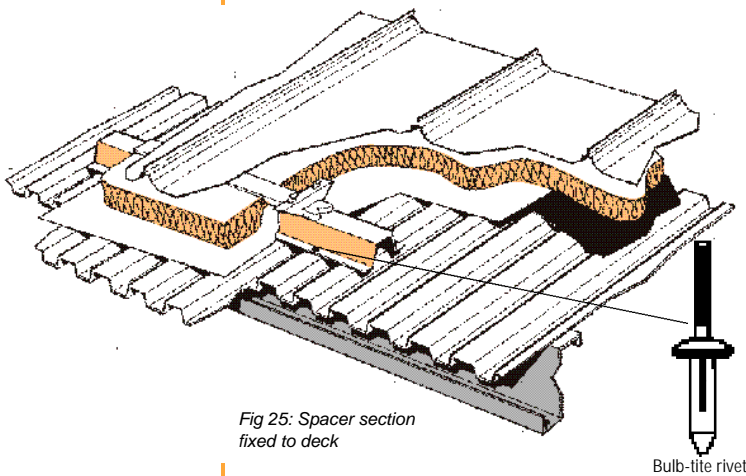

Fig 25: Spacer section fixed to deck

As these decks are often between 0.7 and 1.2mm in thickness, traditional threaded fasteners, neither self-drillers or self tappers as described in sections 3.3 and 3.4, would be considered suitable as there would be too great a risk of overdriving which would seriously reduce the effective performance of this primary fastener and thus put the whole roof system at risk. For this reason, either a purpose-designed fastener where any effect associated with overdriving can be eliminated, or a 'clamping' fastener ie, a structural rivet should be used.

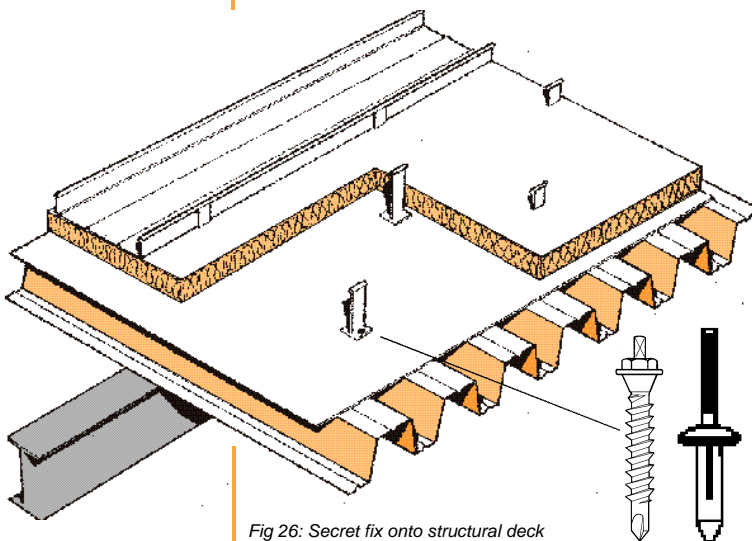

Fig 26: Secret fix onto structural deck

The weatherskin on these systems over structural decks may be the same as with a built-up system whose fasteners are described in section 5.2, or a secret-fix system as described in section 5.4.

## 5.6 Structural liner tray systems

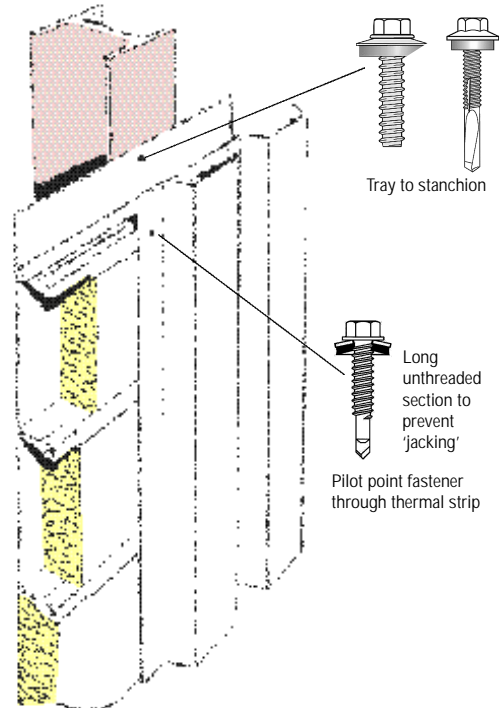

Fig 27: Structural liner tray

A structural liner tray has deep upstands at its side joint which gives the tray its ability to span between the vertical stanchions often eliminating the need for horizontal cladding rails. The profiled metal external cladding sheet is then fixed into the lapped upstands of the tray. This system is normally used on walling however, the same principle could be considered for roofing.

The trays would be primary fixed to the flange of the stanchion with self-drill or self-tapping fasteners often with washers/flanged head to provide pullover resistance.

To prevent cold bridging, there would be a thermal break between the tray upstands and the weathersheet. This is often in the form of a rigid insulation strip. To prevent the weathersheet from "jacking" up the threads, the fastener should have an unthreaded section above the drillpoint of a length in excess of the thermal break thickness. This is called a 'pilot point'.





### 5.6.1 Structural liner to stanchion

Tray to stanchion Hexagonal head  
15mm-19mm washer (or flange)  
5.5mm minimum thread diameter

### 5.6.2 Trapezoidal steel weatherskin sheet, colour coated to tray upstands

Primary fasteners Preferred fastener location - valley  
Factory coloured integral head  
5.5mm minimum thread diameter  
15 -16mm diameter washer on wall.  
Pilot point

Sidelap stitchers If sidelap is on crown on wall, low  
profile head self-driller may be  
preferred  
Factory coloured integral head  
4.8mm minimum thread diameter  
Crown option on wall - rivet + cap  
10mm minimum washers

A further application for metal trays is as a base/deck over which concrete or slate tiles may be fixed. This normally requires the tray to be fixed to purlins with the tray upstands running up the slope. A timber counter batten would then be fixed onto the upstands.

There are purpose designed fasteners available for securing timber to steel. To avoid the need to predrill the timber, and to prevent the timber jacking up the fastener threads, the fastener design incorporates a feature which strips the threads in the timber. This is often a pair of metal wings located between the drillpoint and threads of the fastener. These wings are designed to break off as soon as they hit the steel thus ensuring fastener pullout performance is not compromised. Alternative designs which perform the same function are available.

### 5.6.3 Timber counter batten to tray upstand lap

Countersunk, or flat wafer head  
Anti jacking feature

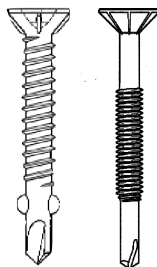
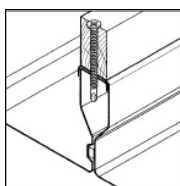

Fig 28: Countersunk fasteners for timber to steel

## 5.7 Rooflight systems

Rooflighting within metal roof systems may be in the form of ridge barrel vaults, upslope eaves-to-ridge barrel vaults, pyramid or dome units, or profiled in-plane rooflights.

This section will define the fixing requirements for the in-plane rooflights. All the other types are usually fixed to a separate kerb or upstand and advice on detailing and fixing should be sought from the relevant supplier.

Rooflights are available in either thermosetting material, GRP, thermoplastic materials, PVC or polycarbonate. The thermoplastic materials usually require a clearance hole to be pre-drilled for the fastener. Check with the manufacturer.

Where there is the requirement for insulated rooflights, they may be either site-assembled or factory assembled. Site-assembled are normally associated with built-up systems (section 5.2) and factory-assembled units with composite panels (section 5.3). Rooflights used in conjunction with secret-fix roof systems (section 5.4) must be selected by reference to the system supplier.

There has been major debate within the metal roofing and cladding industry and, in particular, the rooflight suppliers, on the subject of health and safety and what is a fragile or non-fragile material/construction. This publication is not intended to give specific guidance on health and safety issues. However, tests commissioned by leading GRP rooflight manufacturers and by the MCRMA have shown that the fastener specification and frequency can play an important part in the impact resistance of the cladding system.

**Refer to MCRMA technical paper No 1: Recommended good practice for daylighting in metal clad buildings**



Illustrated below are typical fastener specifications for both site and factory assembled GRP rooflight systems. Fastener spacing depends on the particular rooflight design, material, and loading.

**5.7.1 1.83kg/m<sup>2</sup> GRP site-assembled liner**

Primary fasteners Standard hexagonal head  
29-32mm diameter washer  
5.5mm minimum thread diameter

Liner sidelap Normally a tape as it would not be practical on many lining profiles to mechanically stitch sidelaps

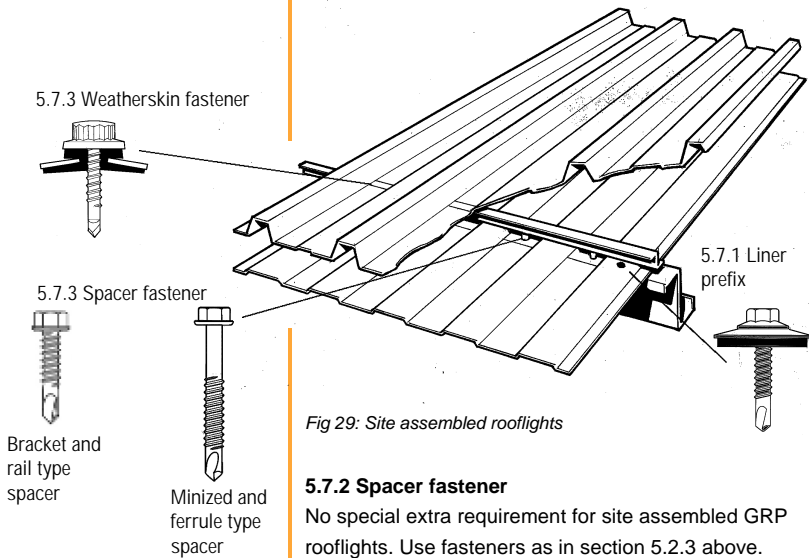

Fig 29: Site assembled rooflights

**5.7.2 Spacer fastener**

No special extra requirement for site assembled GRP rooflights. Use fasteners as in section 5.2.3 above.

**5.7.3 1.83kg/m<sup>2</sup> GRP site-assembled weatherskin to spacer section**

Primary fasteners Preferred fastener location - valley  
Factory coloured integral head, usually bright colour, for example Poppy Red  
29-32mm diameter washer  
5.5mm minimum thread diameter  
Typically every valley or 200mm maximum spacing

**5.7.4 GRP factory assembled rooflights for through-fix composite panel systems**

Primary fasteners Preferred fastener location - valley (check with supplier)  
Factory coloured integral head, usually bright colour, for example Poppy Red  
29 -32mm diameter washer  
5.5mm minimum thread diameter  
Enlarged thread under the head

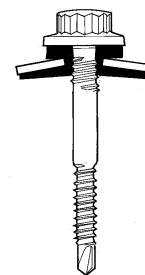

Fig 30: Rooflight self-drilling fastener

**5.7.5 Sidelap stitchers for both site- and factory-assembled GRP**

GRP over metal Factory coloured integral head, usually bright colour, for example Poppy Red  
14 -16mm diameter washers  
4.8mm minimum thread diameter

GRP under metal/GRP

Factory coloured integral head, usually bright colour, for example Poppy Red  
14-16mm diameter washers  
Grommet type clamping fastener requiring pre-drilled holes  
9mm minimum sleeve diameter

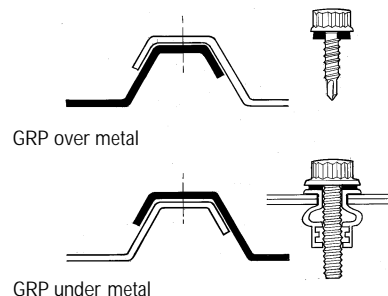

Fig 31: Rooflight sidelap stitchers



# Detailing

## 6.1 Fastener effective thread lengths

The 'workable' length of a threaded fastener is referred to as its 'effective-thread-length'. Threaded fasteners, whether they are the self-drill or self-tapping type, have a lead-in portion which carries out the drilling and threadforming operations. Once correctly installed, this portion of the fastener is redundant or ineffective. The length of this ineffective portion will vary depending upon the type of fastener and its drilling capacity. As noted in section 5.6, some fasteners have an extended un-threaded section between the drillpoint and the threads to prevent jacking when passing through compressed insulant. This also reduces the effective-thread-length.

Some fasteners, for example composite panel and some spacer fasteners (section 5.2.3), are not threaded right up to their head, and therefore there is a minimum, as well as a maximum, effective- thread-length.

When selecting a fastener, the designer/contractor must ensure the maximum effective-thread-length exceeds the total build-up including the support member. Fastener suppliers should publish data on their products giving details of these effective-thread-lengths.

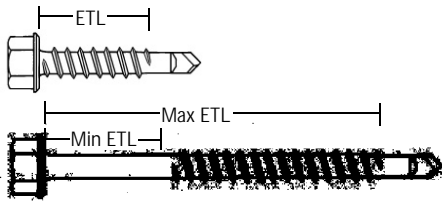

Fig 32: Effective thread length (ETL)

## 6.2 Fastener frequencies

Fasteners, particularly primary fasteners, have to withstand many of the loadings to which the cladding is subjected and transfer them back to the structure. Some of these loadings result in tensile, shear and other forces being transmitted to the fastener, as discussed in section 4.4. Apart from construction, maintenance, and snow loads, perhaps the most critical load that should be considered in order to determine fastener frequencies is that resulting from wind suction.

The designer, engineer or contractor should calculate the windloads in accordance with specified standards. This may be CP3:Chapter V:Part2:1972, BS 6399:Part2:1997, or other specifications, for example Factory Mutual. Once this load has been determined,

the designer, with reference to the fastener and cladding system supplier's data, can ensure that sufficient primary fasteners are specified in order that the relevant safety factors are achieved. With built-up liner panel systems, as described in section 5.2, on light gauge purlins, the spacer section fastener frequency may be more critical than the weatherskin fasteners.

Composite panels, particularly those which have concealed fasteners, typically have fewer fasteners per sheet width than traditional trapezoidal metal profiles, and therefore their frequency should always be checked to ensure it is adequate to withstand the wind loading.

Secret fix systems may transmit other forces on the primary fasteners specific to the particular system, therefore the designer should liaise with the system supplier to ensure all loads have been taken into account.

## 6.3 Lap configurations

Fasteners are applied through endlaps and sidelaps in profiled metal cladding, depending upon the system being used. Frequently these laps also contain weatherseals. The position of the fastener relative to the profile and seals is often critical. The diagrams below are taken from the MCRMA technical paper No.6 *Profiled Metal Roofing Design Guide* and would represent typically good practice.

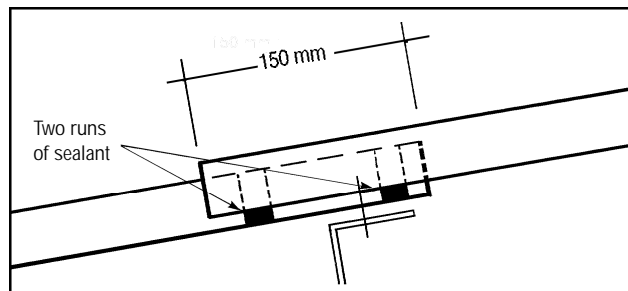

Fig 33: Sidelap sealant

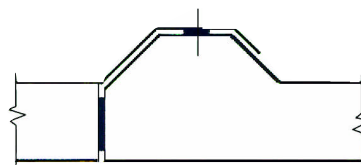

Fig 34: Sidelap joints over 4°



## 6.4 Thermal movement

Even though metal cladding profiles are defined in BS 5427 as 'flexible', materials which have a high coefficient of thermal expansion may require special provisions at fixings. For example, aluminium, which has twice the thermal coefficient of expansion of steel, may require a special endlap detail, depending on the sheet length and colour, to ensure the fastener facilitates the expansion.

Other materials incorporated within metal cladding systems may also require special provisions to accommodate thermal movement. PVC and polycarbonate require pre-drilled oversize holes at fixing positions.

The effect of the thermal movement of composite panels on the fasteners must also be considered for the reasons discussed in section 5.3.2.

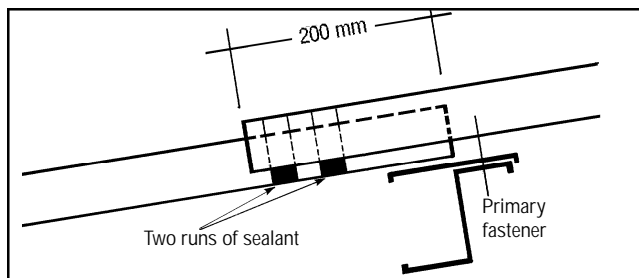

Fig 35: Typical endlap to accommodate thermal movement

## 6.5 Thermal bridging

On built-up metal systems, fasteners would not be considered as contributing to any significant thermal bridging effect. Spacing systems are normally designed with thermal breaks and their effect on the overall thermal transmittance through the roof is normally taken into account when selecting insulation types and thicknesses.

On through-fix composite panels with properly sealed and insulated joints, the only potential for thermal bridging is via the primary fasteners. In practical terms, in the UK environment the effect of fasteners is usually negligible however, if all environmental conditions, including both external and internal temperatures and relative humidities are notified, a qualified assessment may be made.

Where conditions may be critical, it should be noted that the thermal conductivity of stainless steel is approximately 60 percent of the thermal conductivity of carbon steel and therefore creates a smaller thermal bridge.

## 6.6 Flashings

### Refer to MCRMA technical paper No 11: Flashings for metal roof and wall cladding: design, detailing and installation guide

Fasteners have to fulfill a wide range of functional requirements;

- **Durability** Refer to section 4.1 to select the appropriate fastener material.
- **Weathertightness** The fastener often has to clamp and hold the flashing to the profiled sheet or to the adjacent flashing, as well as firmly compressing any seals. Stitching fasteners must be purpose-designed to provide a rigid and secure connection without the risk of threadstripping which could lead to water ingress and/or flashing detachment.
- **Aesthetics** Flashings are frequently designed primarily to weather a junction between two different surfaces, for example roof and wall; flat panel and window; cladding and brickwork. They are often designed to provide an architectural feature to the building. Fasteners for flashings are therefore required to provide a long term colour match to the flashing or cladding. Integral moulded heads may well satisfy the colour match requirement. However, it may be the designer's wish that the fastener is as unobtrusive as possible. As referred to in section 4.3, stitching fasteners are available with factory coloured, very low-profile headforms.

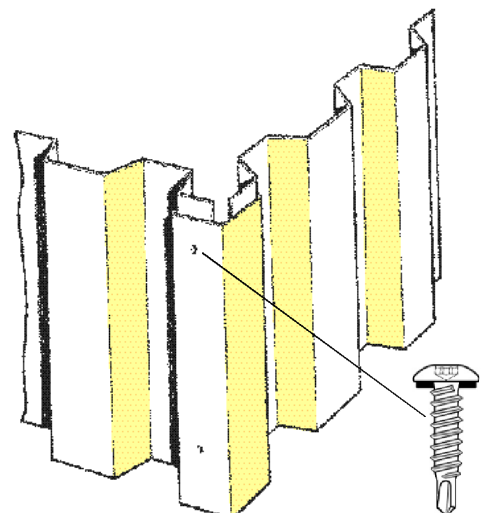

Fig 36: Stitching screw for flashings

Refer to MCRMA technical paper No 10: Profiled metal cladding for roofs and walls: guidance notes on revised Building Regulations 1995 parts L & F



## 6.7 Corrugated profiles

Corrugated or sinusoidal metal profiles, including the industry standard profile as defined within BS 3083:1988, would normally be primary fastened through their crowns to permit free drainage when used in industrial roofing applications. To ensure a seal against the curved metal surface, specially shaped sealing washers should be included. Hook bolts, frequently used in the early years of metal profiles, are not generally recommended today for metal roof sheeting largely due to the availability of self-drillers and tappers, as well as the safety risk to operatives associated with their method of installation. Corrugated metal profiles for walling applications may be valley fixed providing the sealing element is designed and shaped to ensure a seal against the curved valley profile.

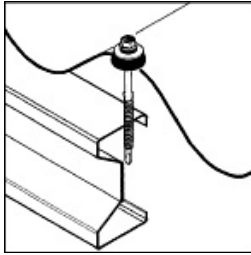

Fig 37: Fixing to corrugated profiles

## 6.8 Fixing to timber

BS 5268:Part2:1991 gives guidance on the structural use of timber. Where threaded fasteners are used for primary purposes to secure metal cladding profiles, or other structural components such as spacer systems, back to timber supports, the timber should be designed in such a way that the edge distances and fastener spacings as defined in the standard and shown below can be accommodated.

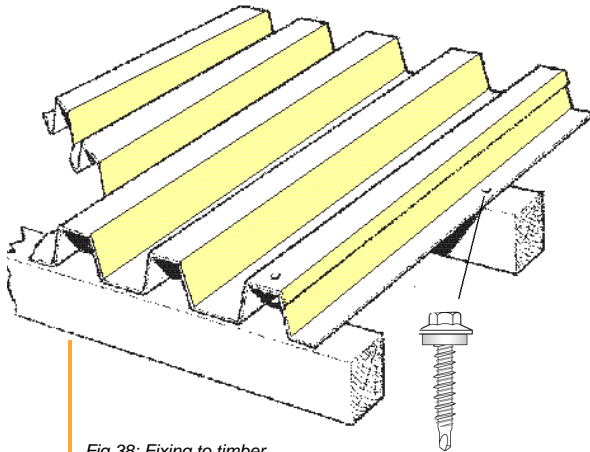

Fig 38: Fixing to timber

Table 3: Minimum fastener spacings

Spacing	With self-drilled or pre-drilled holes
End distance parallel to grain	10d
Edge distance perpendicular to grain	5d
Distance between lines of fasteners, perpendicular to the grain	3d
Distance between adjacent fasteners in any one line, parallel to grain	10d

NOTE:  $d$  is the shank diameter of the fastener

Primary fasteners for securing profiled metal cladding to timber supports are typically a minimum of 6.3mm diameter, often with a "gimlet" type point to facilitate the piercing of the metal. Where standard self-tappers as shown in section 3.4 are used, it is recommended the timber (and metal) is pre-drilled with a small diameter pilot hole in order to release stresses in the timber and prevent splitting. To provide the required pullout resistance of a fastener into timber supports, there must be an adequate thread penetration depth - 35mm is the minimum for most applications however, calculations should be made for verification purposes.

## 6.9 Firewalls

Most metal cladding manufacturers have tested their systems and can provide firewall systems with ratings up to 4 hours. System suppliers must be consulted to establish any specific fastener requirements over and above the typical arrangements shown under section 5.

Where a built-up system includes a mini-zed and plastic ferrule spacer system, as described in section 5.2.3, these ferrules may be made from steel, and not plastics, as is the case in some manufacturers' firewall systems.

It would also be a typical requirement to stitch the lining laps/side joint on both composite and built-up systems. This may be either a threaded stitching fastener or a rivet, depending on the system, but the fastener material must be carbon or stainless steel and not aluminium.

## 6.10 Material compatibility

The risk for bi-metallic corrosion between components of different metals should be assessed by the designer. PD 6484:1979 *Commentary on corrosion at bi-metallic contacts and its alleviation*, may be referred to in order that any risk can be assessed. Consideration must be made to the relative surface areas of the metals in contact and the moisture content of the environment.



## References

To prevent bi-metallic corrosion at the connection, the fastener should be of a material with, at least, the equivalent corrosion resistance to the material being fastened into/through. For these reasons, stainless steel fasteners securing steel or aluminium profiles to galvanised steel support sections are considered a suitable combination, whereas carbon steel fasteners are not considered suitable for securing aluminium sheeting.

Perhaps the main risk within metal cladding systems occurs where aluminium profiles are in contact with galvanised steel spacers or supports. It is recommended practice therefore, in these conditions to apply a separation layer, usually an adhesive barrier tape, over the whole surface of the support component in contact with the aluminium.

### 6.11 Swimming pools

It is acknowledged within the document entitled *Stainless steel in swimming pool buildings* published by the Nickel Development Institute, that certain grades of stainless steel may be at risk of chlorine-induced stress corrosion in conditions which may occur in swimming pool halls. It is therefore recommended that such grades should not be used for applications which may be classed as 'safety-critical', ie in those applications which may result in personal risk/injury in the event of failure.

Various grades of stainless steel fasteners offer the designer appropriate and readily available solutions with an acceptable corrosion risk. The specific application must be discussed with the fastener manufacturer/supplier.

### 6.12 Fastener penetrations

The client/designer may find it desirable, either for safety or aesthetic reasons, to minimise the length or protect the portion of fastener visibly protruding on the underside of the supporting structure. Push-fit screwtip caps may provide an acceptable solution. In applications where the protruding length is required to be reduced then this should only be considered where the supporting element is of a thickness such that the pullout performance of the fastener, in practical terms, will not be adversely affected. Typically this would only apply to hot-rolled steel of at least 6mm thickness and not to cold-rolled sections and decking applications. The method of reducing the penetration length should not transmit any tensile forces to the fastener and grinding or cropping may be considered. Where applicable, any corrosion protection to the fastener should be reinstated.

#### British Standards

BS 1494:Part1:1964	Specification for fixing accessories for building purposes Fixings for sheet, roof and wall coverings
BS 3083:1988	Specification for hot-dip zinc coated and hot-dip aluminium/zinc coated corrugated steel sheets for general purposes
BS 5268:Part2 1991	Structural use of timber. Code of practice for permissible stress design, materials and workmanship
BS 5427:Part1:1996	Code of practice for the use of profiled sheet for roof and wall cladding on buildings
BS 5950:Part9:1994	Code of practice for stressed skin design
BS 6399:Part2:1997	Code of practice for windloads
BS 7543:1992	Guide to durability of buildings and building elements, products and components
CP3:ChapterV: Part2:1972	Code of basic data for the design of buildings. Wind loads
PD 6484:1979	Commentary on corrosion at bi-metallic contacts and its alleviation

#### Other publications

ECCS No.66	Preliminary European Recommendations for Sandwich Panels. Part1 Design
NDI	Stainless steel in swimming pool buildings. Published by the Nickel Development Institute
NFRC	Profiled sheet metal for roofing and cladding. A guide to good practice Third Edition 1999. Published by E N Spon on behalf of the National Federation of Roofing Contractors
HSG 33	Health and Safety in roof work. Published by the Health and Safety Executive



# MCRMA technical papers

## Liability

*Whilst the information contained in this design guide is believed to be correct at the time of going to press, the Metal Cladding and Roofing Manufacturers Association Limited and its member companies cannot be held responsible for any errors or inaccuracies and, in particular, the specification for any application must be checked with the individual manufacturer concerned for a given installation.*

*The diagrams of typical constructions in this publication are illustrative only.*

- No 1 Recommended good practice for daylighting in metal clad buildings
- No 2 Curved sheeting manual
- No 3 Secret fix roofing design guide
- No 4 Fire and external steel-clad walls: guidance notes to the revised Building Regulations, 1992
- No 5 Metal wall cladding design guide
- No 6 Profiled metal roofing design guide
- No 7 Fire design of steel-clad external walls for building: construction, performance standards and design
- No 8 Acoustic design guide for metal roof and wall cladding
- No 9 Composite roof and wall cladding panel design guide
- No 10 Profiled metal cladding for roof and walls: guidance notes on revised Building Regulations 1995 parts L& F
- No 11 Flashings for metal roof and walls: design, detailing and installation guide

## Other publications

The Complete Package CD ROM

Manufacturing tolerances for profiled metal roof and wall cladding

Built-up metal roof and wall cladding systems: tables of insulation

Noise insulation using profiled metal cladding: the advances in recent years

Cladsafe latent defects insurance scheme: basic guide

MCRMAMembership Charter



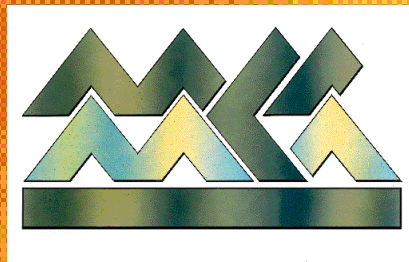

**THE METAL CLADDING & ROOFING MANUFACTURERS ASSOCIATION LIMITED**

18 MERE FARM ROAD  
PRENTON · WIRRAL  
CHESHIRE CH43 9TT

TELEPHONE: 0151-652 3846  
FACSIMILE: 0151-653 4080  
mcrma@compuserve.com  
[www.mcrma.co.uk](http://www.mcrma.co.uk)